

ABC

BUILDING SYSTEM

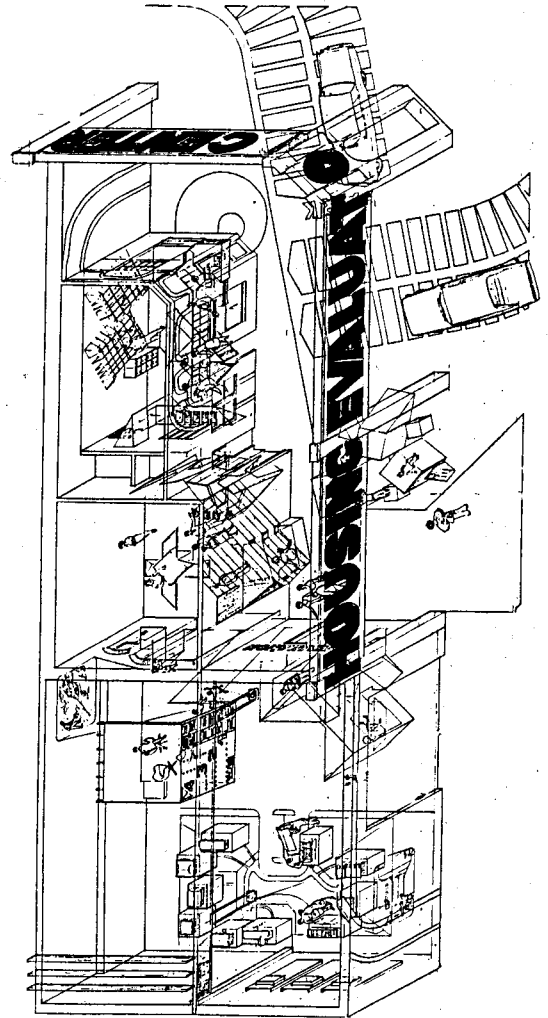

B. MATHER

SUSTAINABLE DESIGN ASSOCIATES

CENTER FOR MAXIMUM
POTENTIAL BUILDING SYSTEMS
8604 F.M. 969
AUSTIN, TEXAS 78724
512/928-4786

SUNSTRUCTURES, INC.
601 EAST 46TH
AUSTIN, TEXAS 78751
512/454-3777

PREFACE

As dependencies between issues in the built environment become increasingly complex, it is necessary to understand the built environment's impact on the natural environment and on the people who live there. This industrialized housing proposal is developed through a conceptual model that addresses a multitude of these impacts, though not all are undertaken in this phase.

It assumes, for example, an initial step of regional assessment and development of a natural resources inventory. The scope of such an inventory, although not accomplished in this study, would survey Maricopa County and include its geology, soils, vegetation, hydrology and climate. It would then identify the extent to which these regional resources are used by the region's manufacturing and business community to facilitate incorporation of these into the building process. The entire analysis would be done in a coordinated effort with a variety of regional agencies. Together, these steps would demonstrate how regional resources could be used in particular combinations that would promote adoption of building methods and resources that could be sustained for the longest possible duration. The resulting building system would be accessible to people most in need of housing and, additionally, support the multitude of regional businesses that, because of their dependencies on regional resources and clientele, would provide significant economic multipliers.

Specifically, the proposed approach would foster more ecologically based planning methods, extensive import replacement as a basis for regional economic development, and lowered embodied energy costs for the materials used in building. In addition, the approach would stabilize housing stock by fulfilling housing needs through an array of regionalized building methods that are insulated from unpredictable national and international events. Thus, the resulting building system would link a variety of public and private entities which would become mutually supportive, and whose linkages would be galvanized by solid relationships between the local chambers of commerce and offices of economic development.

For example, the 147 mining operations now existing in Maricopa County would be reviewed as to proper bioremediation practices through the Bureau of Land Management (B.L.M.), and would also be linked with new building-related market potentials that would emerge as a result of the coordinated economic development efforts. These could include building materials made from unfired, low energy pressed soil appropriate for 48 of the available soil types, or from agricultural or forest wastes whose product manufacturers would in turn be coordinated through such agencies as the Soil Conservation Service, the Agricultural Extension Service, and others which would be responsible to ensure that essential ecological practices such as respecting food producing soils and returning organics to the soil were honored.

Also, new institutions would develop such as our proposed "ABC Building Systems Mart" that would be sophisticated regional material and housing system outlets, evolving from the 1990's top of the line hardware/lumber yards but more closely linked with and owned by the regional manufacturers. These would be among the "deliverables" resulting from the closer coordination between businesses, regional resource planning efforts, and economic development programs

and would be reflected in specific building components and floor plans such as those described in the relational field matrix below. As one can see each component of the building system from region to individual building detail are relatable one to the other so that one can track impacts throughout the system. On site energy systems would have relational links to regional capacity for raw materials, the same with water food and otyher subsystems that are too often taken totally for granted in present industrialized housing techniques. Much further development of individual components throughout this relational method of industrialization would need further development and are not all included here.

**RELATIONAL MATRIX FOR ABC
BUILDING SYSTEMS - A COORDINATED
REGIONALLY MANUFACTURED BUILDING
SYSTEM**

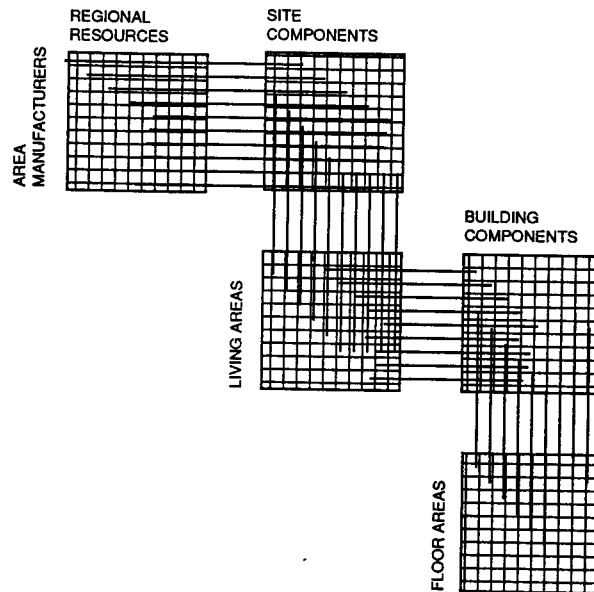

The proposed approach also assumes an evolution in the relationship of the user to the design and building processes. The "ABC Building Systems Mart" would, for example, be a user's paradise where the entire home can be designed by the occupant from top to bottom, with constraints posed only by the region's limits in natural resources, craftspeople, and artisans that have assumed integral roles in the regional building systems, whose design and engineering are purposely made to foster such relationships. In addition, state-of-the-art electronics would enable random access of material, color, and texture options and enable the user to "walk through" their house before it is built using virtual environment software such as is described in this report. Interactive three-dimensional models simulating individual and community space would be part of the Mart, similar to the model presented in this report, but which would be constantly monitored as to cost, total energy, food production, etc. through computer software responding to each model move.

The "ABC Building Systems Mart" would also contain CAD systems coordinated with each regionalized material, resulting in an efficient drafting method for subcontractors and/or owner-builders. All systems-- CAD, Site Planning Model and the Virtual Environment Simulation-- would be linked in order for participants to understand as fully as possible what their future living environment would "really" be like. One such scenario of a simulation facility was developed in 1971-1972 by Bob Mather, past professor of architecture at the University of Texas and visiting professor at the University of Oregon. This report's cover and the plan below are borrowed from these early efforts.

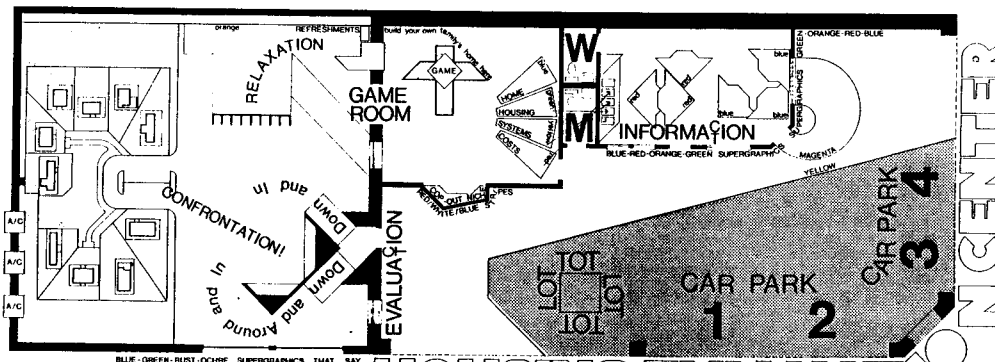

BLUE-GREEN-RUST-OCRE SUPERGRAPHS THAT SAY

HOUSING EVALUATION

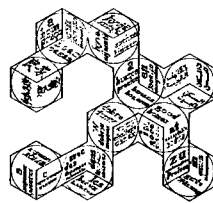

October 11, 1982

The following evaluation report is a summary of the report and the results of the evaluation of the Housing Evaluation Center, which was held in the building laboratory by some of the members of the Housing Evaluation Center. The purpose of this report is to identify the principles used in developing the physical setting for the Housing Evaluation Center. The center is designed to be a model of a housing development in which the members of the center can evaluate the physical setting and the social, cultural, and economic conditions that affect the quality of life in a housing development. The center is designed to be a model of a housing development in which the members of the center can evaluate the physical setting and the social, cultural, and economic conditions that affect the quality of life in a housing development.

Three aspects of each report, one, two, and the year, were used to form the basis of the evaluation. The first aspect is the year of the report, which is the year of the report. The second aspect is the number of the report, which is the number of the report. The third aspect is the title of the report, which is the title of the report.

The following report is a summary of the report and the results of the evaluation of the Housing Evaluation Center, which was held in the building laboratory by some of the members of the Housing Evaluation Center. The purpose of this report is to identify the principles used in developing the physical setting for the Housing Evaluation Center. The center is designed to be a model of a housing development in which the members of the center can evaluate the physical setting and the social, cultural, and economic conditions that affect the quality of life in a housing development.

MARKETING

ONE-STOP SHOP: AN IDEA WHOSE TIME HAS COME?

Imagine a home buyers' supermarket that stocks everything from land to floor plans to building services and financing, all under one roof.

The roof belongs to Rittenhouse Homes Corporation's Custom Home Center, which opened 15 months ago in a busy shopping center in Tampa.

The center offers customers services tailored to their specific needs. If a prospect is in search of a lot to build on, for example, the center will help him find it through individuals or developers who have listed their land with the center (and will get the usual real estate commission).

If it's plans and specifications the customer wants, he can get those too, at just 40 cents a square foot, a bargain considering it costs Rittenhouse \$1.50 a square foot. At that point customers are free to walk out with blueprints, but they don't. Eighty-five percent

elect to have Rittenhouse build the home, and that's where the real payoff begins. Since opening, the center has signed contracts on 45 homes ranging from \$97,000 to \$350,000.

That 85-percent conversion rate doesn't just happen. During planning, the prospect pays at least four visits to the center lasting two to four hours each. The design staff of one architect and six draftsmen develop preliminary floor plans on IBM PCs based on client sketches and discussions.

By the time the plans have been finalized two weeks later, home buyers have been given a liberal education in the intricacies of home building. They have been carried through every step, learning why budget constraints make compromises necessary, why one idea is practical and another not, and, above all, learning to trust the center. "We take the agony out," says Mim



Home Center draftsman develops plan and specifications with AutoCAD system on an IBM PC.

Eshenbaugh, Rittenhouse vice president. "Our clients say they come away with a real understanding of how the house goes together."

When the plans are complete, Rittenhouse works out the specifics and sets a price. A mortgage broker is available to help with financing, and interior designers are on hand too.

Customers are treated to display of carpeting, cabinets, furniture, fixtures and more, and are provided with a five-year plan for completing the home. If they can't afford draperies for the dining room today, they come back next year for them. The same is true for everything else that goes into a house, including the landscaping.

The Home Center is attracting nationwide attention. A recent article in a consumer magazine provoked seven calls from interested consumers around the country the first day it hit the stands.

Although Rittenhouse is not planning to franchise the Home Center, it is willing to advise and help others interested in copying their idea. Their phone number is (813) 977-8323.

"You need a knock-out center in high-traffic area," Eshenbaugh says. "Count on \$250,000 going in, and being able to carry yourself for six to eight weeks." — JANE MOSS SNOW, A FREELANCE WRITER IN WASHINGTON, D.C.



Rittenhouse's Custom Home Center displays several thousand items, ranging from shingles to wallpaper. It doesn't charge manufacturers a fee to participate.

OUR APPROACH

"...The question of how architecture should relate to technology has indeed never been more pressing, while the question of how the architect should relate to society, to client, user, and builder, is one which architects, ostrich-like, continue to ignore. Finding fault with the style of the 50's and 60's, the architect of today sees a change of style as the obvious solution. It never strikes him that it might be his role which is wrong, the whole process by which buildings are designed and built that needs changing...

"...The complete opposition between the architect's vision and the means by which the people express the reality of their habitation reflects an underlying political power struggle and throws into question the architect's right to impose an exclusive image, especially on a domestic program. Few architects today are prepared honestly to face this problem...."

Peter B. Jones, 1986
(Translator's Forward)
An Architecture of Complexity
by Lucien Kroll

This proposal foresees a change in the role of architecture in the 21st century. Under the skin of our post-modern buildings of the 70's and 80's lies the same buildings of the 50's and 60's. Throughout the course of the last half of the 20th century, there were no fundamental changes in the way buildings were designed, built, or used, save for a flurry of energy-conservation activities. We seek not to determine a new building **product** from the architectural practice of the next century, but to create a design **process** through which emerges a truly vernacular architecture which is ecologically resonant (particularly in terms of resource utilization), user friendly, and energy efficient in both embodied and operating costs.

We propose a method by which design is achieved through a complex group process involving clients, users, manufacturers, inhabitants, builders, and regional planners. The architect's role shifts from one who imposes his or her will in making all decisions, to one who plays the part of organizer and catalyst, sparking the project without retaining total control over its outcome. Through the design of an open system, the architect creates an opportunity in which choices are available in how the user, the developer, and the manufacturer can be brought together in a cost effective package that lets the outcome "evolve" from the input of each participant. Thus, the design process becomes, in a sense, participatory regionalism.

This participatory design process is not an established step-by-step procedure, even though it has been used by many groups in recent years. (See especially Co-Housing: A Contemporary Approach to Housing Ourselves.) It is a process that requires flexibility, compromise, and non-traditional skills of conflict resolution. Every situation will be different, determined by the participants, the development,

the site, the budget, and many other factors. Residents will assume greater responsibility in determining their housing needs and in understanding the design process. Architects will need to nurture their ability to work in groups and "design teams," to make technical problems understandable, and to consult with others when making choices. Yet, we believe that only through such a process can a successful housing community be built, assuming a broader definition of "successful".

Furthermore, this participatory design process will be guided by a set of rules. Most of these rules already exist and fall under the 20th century conventions, zoning ordinances and building codes. Architects, developers, and builders are required to follow these rules on every project in which they are involved. In addition to the rules of the present day scenario, we are proposing new rules and concerns that will emerge in the next two or three decades, and that will influence all building design in the 21st century. Some of these rules will influence site design and layouts, and others will influence individual buildings. Together they will alter the way developments are planned, designed, and built.

This proposal, therefore, presents a new set of rules to be followed in the design of the proposed 21st century house. Some of these rules are completely new, some replace older regulations, and some are logical extensions of present day ordinances. These rules, when followed by the participatory team, describe a "design game" in which the design "problem" is solved by all participants in a cooperative manner. Although the rules are very specific and touch upon every phase of the project, there are an unlimited number of possible outcomes.

Also proposed is a new approach for the manufacture and use of industrialized components to be used in the construction of housing. We do not foresee the use of components made from imported, energy intensive, expensive materials that can be assembled in a few limited combinations. Rather, we envision an open, changeable list of components made from regionally and locally available materials, including recycled materials, and manufactured by area businesses and industries. These would be distributed through a separate "Building Mart" that provides design and construction services as well as the building components, as described in the Preface.

In short, we propose that people should be given the opportunity to design their own homes and be allowed to live as they wish. We believe that the dwellings will be more responsive to the needs of their owners if the owners are able to participate in the design and construction. The owners also will be more likely to improve and maintain their dwellings if they are built through their own efforts and if the commitment to the project is made at the outset.

ASSUMPTIONS : Without a specific site, certain assumptions had to be made concerning the location of the project and the geographic, climatic, demographic, and regulatory conditions that exist at the time this housing project may be built.

Site Location : The program states that the site is located in a neighborhood with a mix of single and multi-family dwellings. A "mixture" of 2-4 story residential, commercial, and industrial buildings, as well as some public open space and recreation areas, are adjacent to the site. Although the program states that there are no existing streets or site infrastructure, we are assuming that a secondary or tertiary vehicular road exists along one of the property lines of the site. This road can provide vehicular access in and out of the 20 acre area.

Zoning Ordinances : In the year 2030, local ordinances will still exist that specify density, minimum lot size, setback requirements, height limitations, and other standards similar to those employed today. As stated in the program, allowable density is 16 units per acre. Parking requirements call for 1.25 off-street parking spaces per unit. New zoning ordinances will create three dimensional zoning maps. These maps will describe solar access, daylighting, and air space restrictions. (See the discussion on the solar envelope)

Water : Years of off and on drought conditions in the Southwest have slowed down development in the area. By the year 2030 municipalities will have to fund and construct huge desalination plants to produce fresh water. Methods have been proposed and implemented to distill water from salt and waste water. Water provided by the local municipality is very expensive and the city has offered rebate programs to homeowners who install water conserving fixtures. Recently, the building codes officials have discussed the possibility of requiring grey and waste water treatment systems be installed in all new construction.

Fossil fuels : The energy industries are no longer subsidized and gasoline costs \$4.25 gallon (in 1990 dollars). Alternative fuel vehicles (natural gas, hydrogen, solar electric) are available on the marketplace. Strict energy codes have dictated the use of energy efficient appliances in new construction. This has created a demand for new products, such as a combined refrigerator/water heater. Passive heating and cooling techniques are employed in almost all new construction.

Building materials : High costs of transportation have forced builders to consider local and regional sources of building materials. Lumber from the northwest is no longer harvested at the rates of the previous century. Many of the "miracle" polymer products have been found to be toxic and damaging to the environment during manufacture. Fiberglass materials have also been "phased out" of use due to health hazards during manufacture and disposal. Codes are requiring non-CFC foam products in all new construction.

Demographics : As stated in the proposal, the residents are a diversity of family and non-family households. Two parent families will continue to decline in number. Single parents, people who live alone, and people who live with other unrelated persons will continue to be a large segment of the market. The baby boomers of the 40's and 50's will be 70 - 90 years of age. The senior population will continue to grow and many of these seniors will live alone but wish to live in a community setting. There will be a need not only for a variety of housing units, but also for the possibility of easily and inexpensively remodelling and changing individual houses.

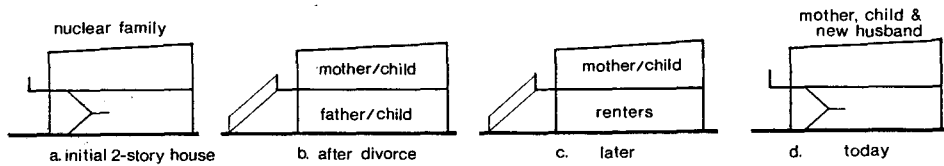

A dwelling changes as the needs of the inhabitants change.

SPATIAL NEEDS OF EVOLVING FAMILY

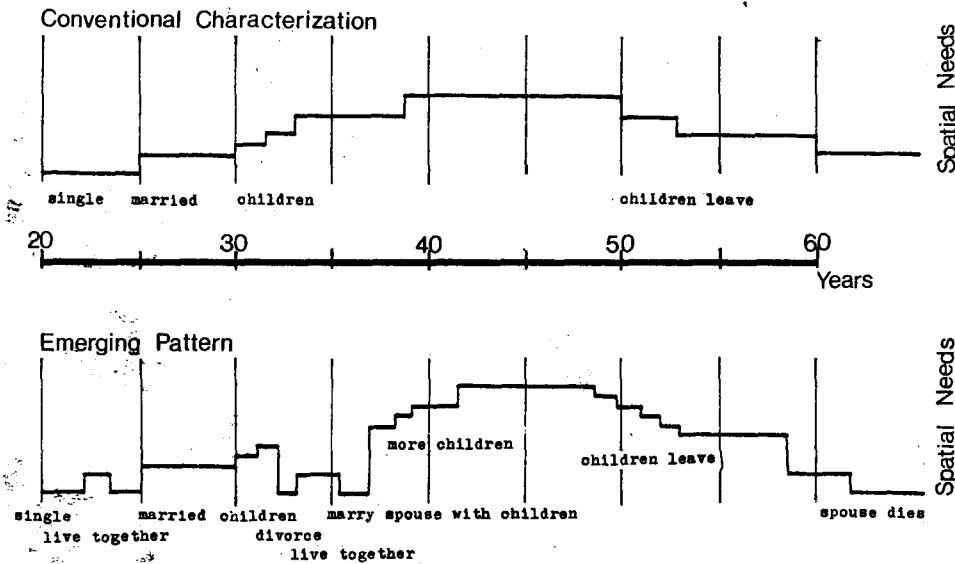

Costs : Labor costs are high. Anyone wishing to purchase a residence for \$55,000 (in 1985 dollars) must do some of the actual labor during the constructing or finishing of the dwelling. Self-help and sweat equity labor will be essential for some potential homeowners to move into the development. This may range from doing most all of the interior work, laying floors, installing cabinets, to simple finishing touches such as painting and wallpapering. Not only does the owner builder option reduce costs, it also allows interiors to be customized to fit the individual's choices. Different types of building packages will be offered such as the "resident built infill" (completing the project after the frame is erected), "resident built interiors" (partitions, cabinets, etc.), and "resident finishes" (painting, etc.).

SITE COMPONENTS

Besides the usual set of zoning ordinances for density, parking, and open space, in the twenty first century there will be many new requirements that must be considered in the development of a potential building site. Some of these requirements will address on-site waste treatment, water collection and conservation, and greenhouse effect/CO₂ abatement. We shall examine a few new zoning ordinances that we considered during the site design process for this project.

Solar access : Solar access ordinances will deal not only with the sun as an energy source for water and space heating and electric generation, but also as a source for daylighting important to the overall quality of life. Assured access to the sun for all dwelling units may be implemented in a series of ordinances defined as the Solar Envelope. Our concepts of how we may utilize solar energy will change in the future. Current technologies may not last or may be substituted for more efficient methods. Important contributions to our needs provided by the sun can only be guaranteed if we retain access to it.

The zoning ordinances of the future will go beyond thinking of solar insolation as merely another energy source. New ordinances will extend the concept of solar access to support an improved quality of life and recognize that solar gain and daylighting are a primary condition for physical and mental health. "Solar access keeps future options open in the event that changing technologies and aesthetics make the sun more, not less, valuable." (Ralph Knowles) Because of these concerns, we have recommended that the site be located in a community that has adopted a "solar envelope" type of three dimensional zoning.

As stated by Ralph Knowles, the solar envelope is a three dimensional construct based on two premises. First, it assures solar access to the property surrounding the given site. Secondly, it defines the largest developable volume within certain time constraints. It describes the largest container of space that would not cast shadows off-site at specified times of the day (cutoff times). Conventional zoning allows the largest volume on a land parcel with no consideration of solar access. The solar envelope regulates the shape of that volume. In short, the solar envelope defines the volumetric limits of building on a specific site that will not shadow surroundings at specified times.

Mr. Knowles proposed the use of solar zoning charts in the future. These would be "simple charts that translate all solar data into envelope slope angles that could be laid out on the site. Such tables could easily be devised for any given latitude." The selection of envelope angles would be based upon the orientation of the site and the cutoff times for solar access. With such charts, one could determine the building limits "in the field or on the drawing board."

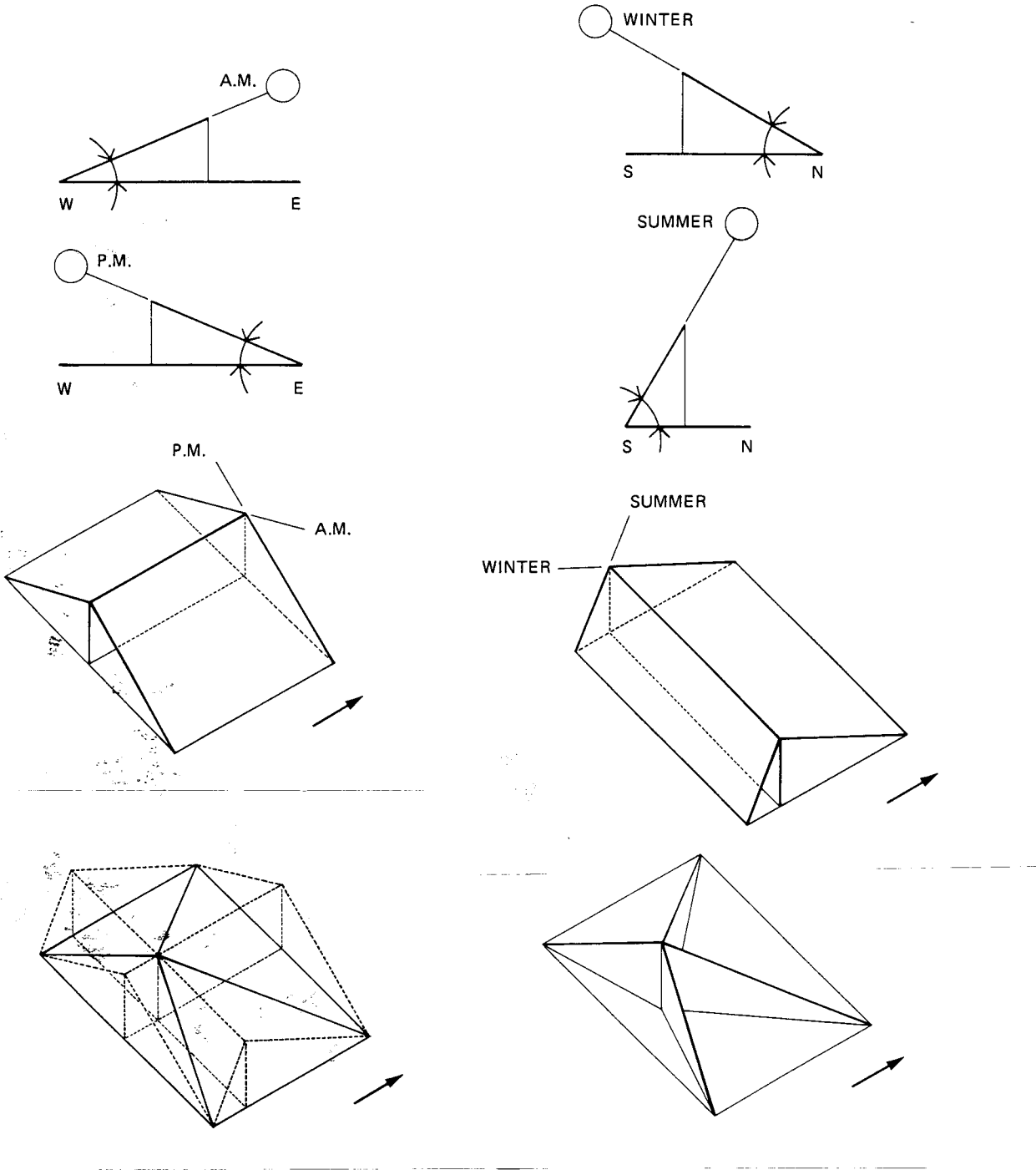

Generation of the solar envelope from daily and yearly limits and the integration of the two.

Various conditions on and at the boundaries of a site affect its envelope's size and shape. Setbacks, topography, adjacent structures, natural features, and open space all influence the limits of the building structure. The orientation of the site along the cardinal points or "off the grid" at a different angle will change the envelope's shape. Whether or not the site is platted on a north-south or east-west direction changes the envelope's boundaries.

The solar envelope for an entire site, oriented east-west would be different than when oriented north-south. For example, solar envelopes over east-west oriented sites will have a higher, shorter ridge located near the south boundary of the site. Solar envelopes on north-south sites will have a ridge running lengthwise down the center of the site. Diagonal orientations create even different solar envelopes.

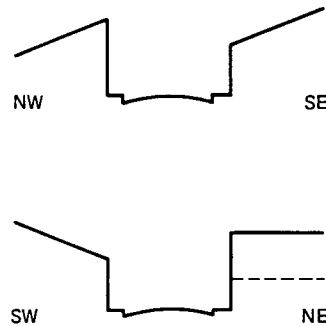
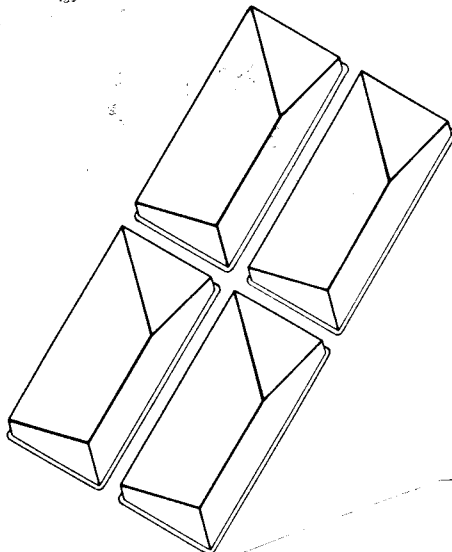
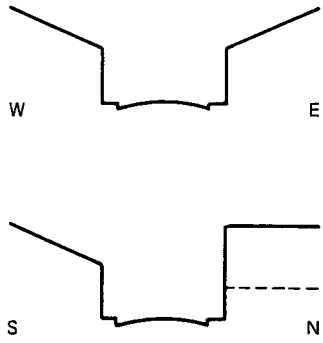
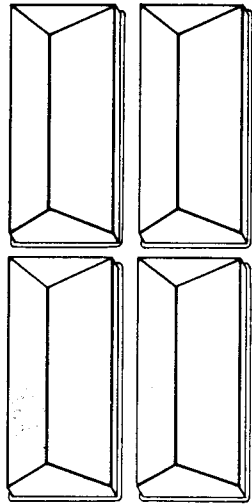
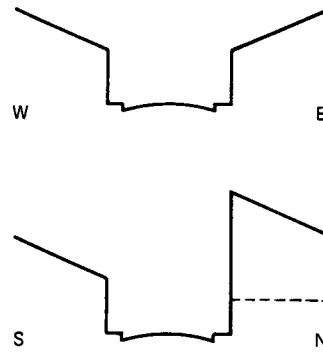
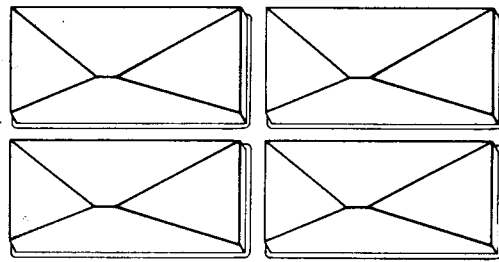

In cases of residential development, the entire site is likely to be subdivided into smaller, unequal parcels. The sizes and locations of these parcels will be determined by type and density of the dwelling units (single family or multi-family) and important features of the site, such as vegetation, vehicular access and other design criteria. The site then becomes an assemblage of smaller solar envelopes, each defining the building limits of a dwelling or cluster of dwellings. The volume of each smaller envelope will be designed to assure solar access for all the other envelopes within the site, as well as beyond the boundaries of the site. This can be done in a very regular pattern, as for a city block, or a more complex pattern, as for a mixed use site.

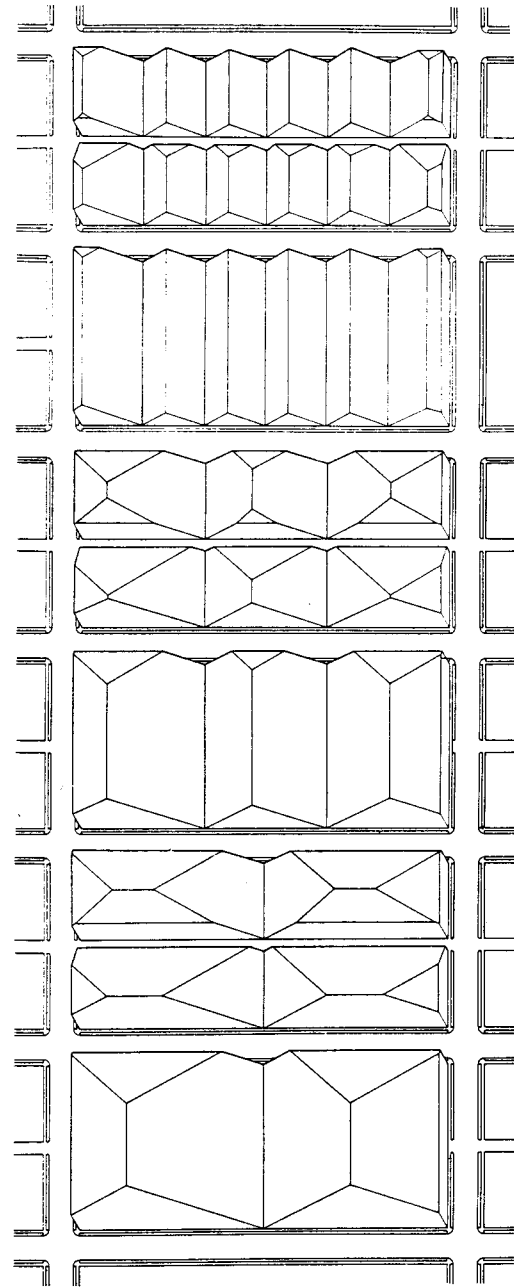
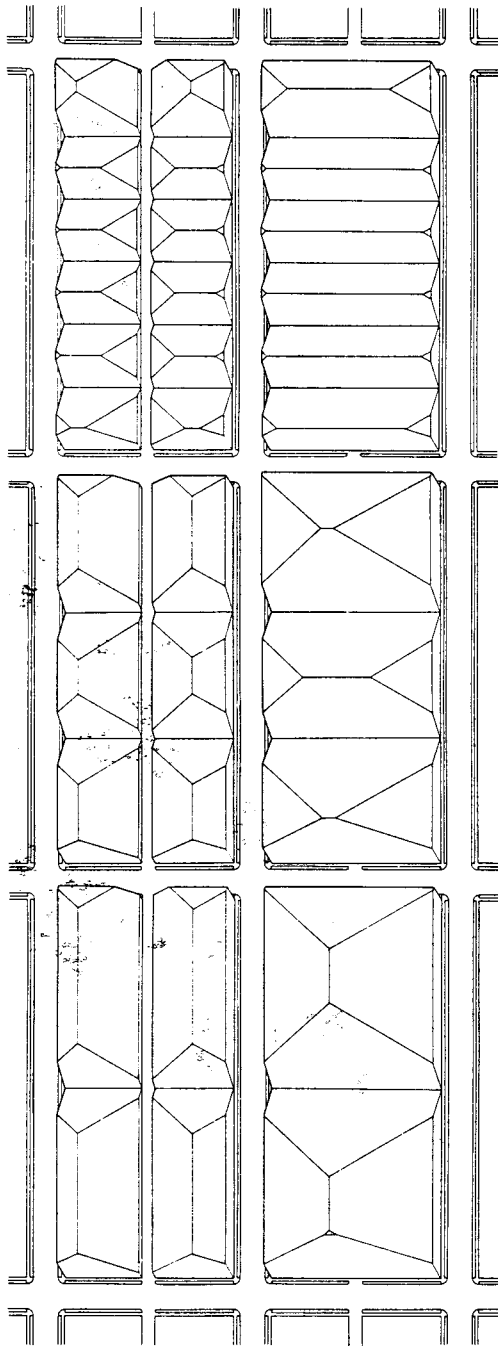

The application of the solar envelope to site design is assumed to be a requirement for this development. Therefore, we located, oriented, and designed the dwelling units so that they conformed to their particular solar envelope. The form of the "house clusters" was in a large part determined by the solar envelope concept. They must be attached in such a way as to assure solar access to their neighbors *and* assure solar access and environmental quality to development within their own solar envelope. Daylighting, natural ventilation, and solar energy should be provided for every dwelling within each "house cluster."

A characteristic design of 8 to 12 row houses in a cluster would be to locate the highest units in the center, the medium height units on each side, and the lowest units on the ends of each row. With one, two, and three story units, 2-3 three story units would be in the center, flanked by 2-3 two story units, with the one story units on the ends. The roofs of the dwellings decrease in height from the center to the ends of each row. This forms a cascade of roofs (or roof terraces and gardens) in each "house cluster." The precise shape of these rooftops is such that the sun between cutoff times illuminates the roofs and walls of the units to the north. The southern units must be carefully designed to allow both the greatest height and solar access for the northern row. The southside of each dwelling unit in the cluster will expose as much wall and roof as possible for its own solar access. On the north side spaces will be smaller, lower, and shallower.

The planning of interior spaces is also influenced by the solar envelope concept. The upper parts of units naturally receive greater access to the sun when rows are close together at typical multi-family densities. Three story units may have major living spaces located above minor ones, living rooms on top floors over kitchen and dining rooms below.

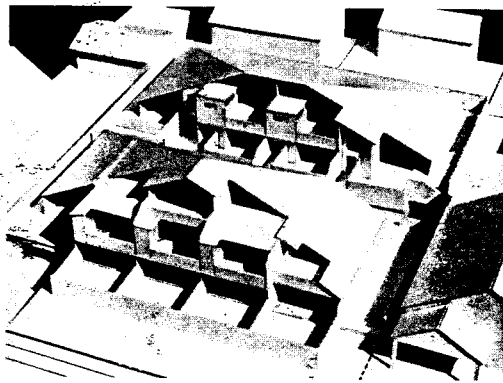

*View from southeast; 9 A.M., equinox.
Designer, Rich Knarr.*

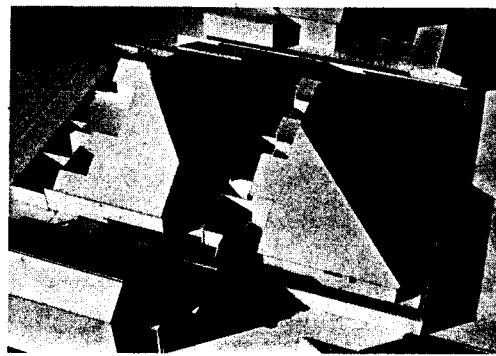

*View from northeast; 9 A.M., winter.
Designer, Rich Knarr.*

Multi-family housing projects, infill site with 30 units per acre and corner site, 54 units per acre (next page).



*View from southeast; 9 A.M., winter.
Site envelope plus street trees.*

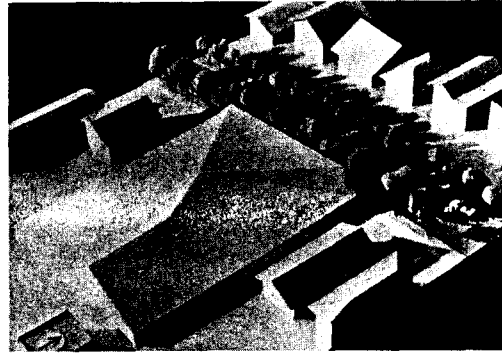

3 P.M., winter.

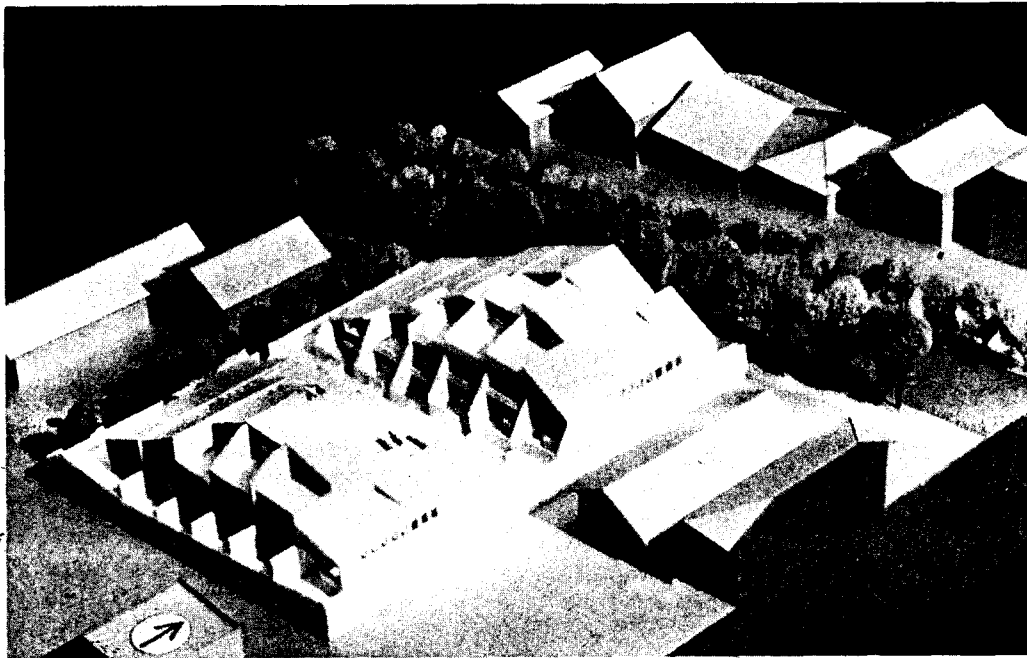

*9 A.M., summer.
Designer, Rodrigo Brana.*

SITE COMPONENTS

SC

SOLAR ENVELOPE

Figure 63. Street as Shadow Buffers

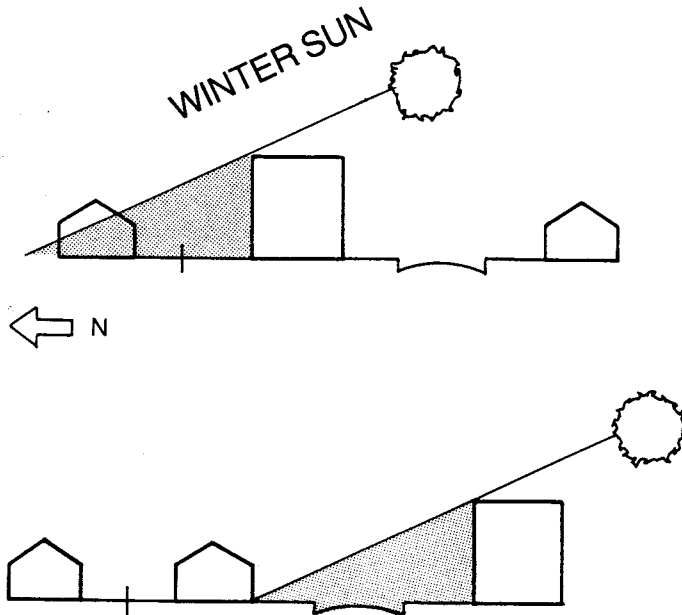

Figure 58. South-Wall Access Limited by 35-Foot Tall Building to South
140' NORTH SHADOW PROJECTION

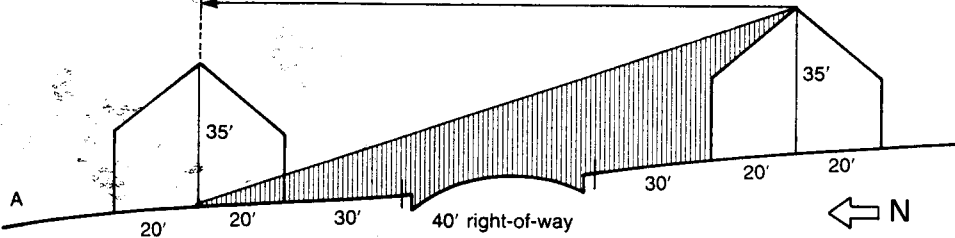
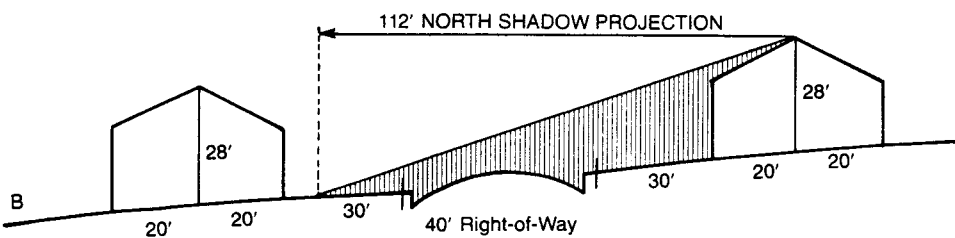

Figure 59. South-Wall Access Protected by a 28-Foot Tall Building
112' NORTH SHADOW PROJECTION



SITE COMPONENTS

SC

Figure 36. Reducing Building Height to Improve Solar Access

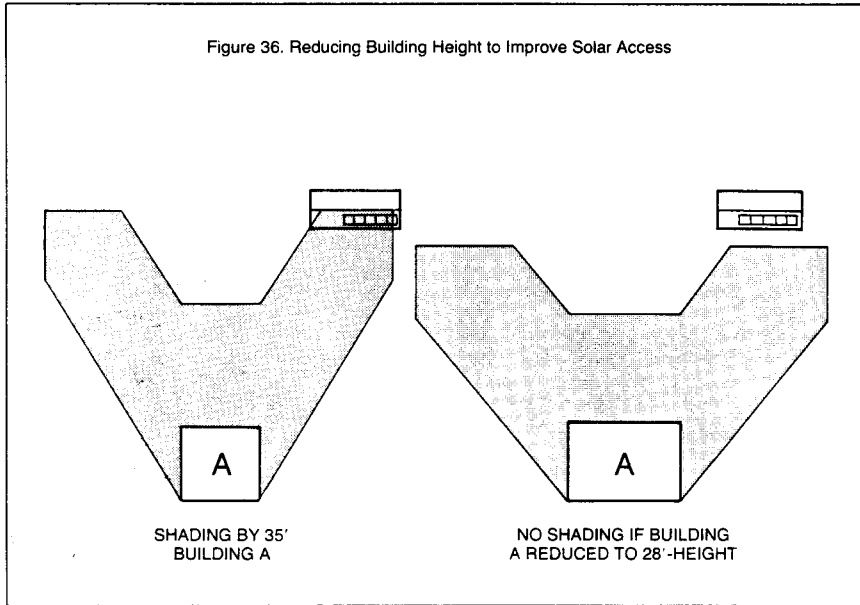
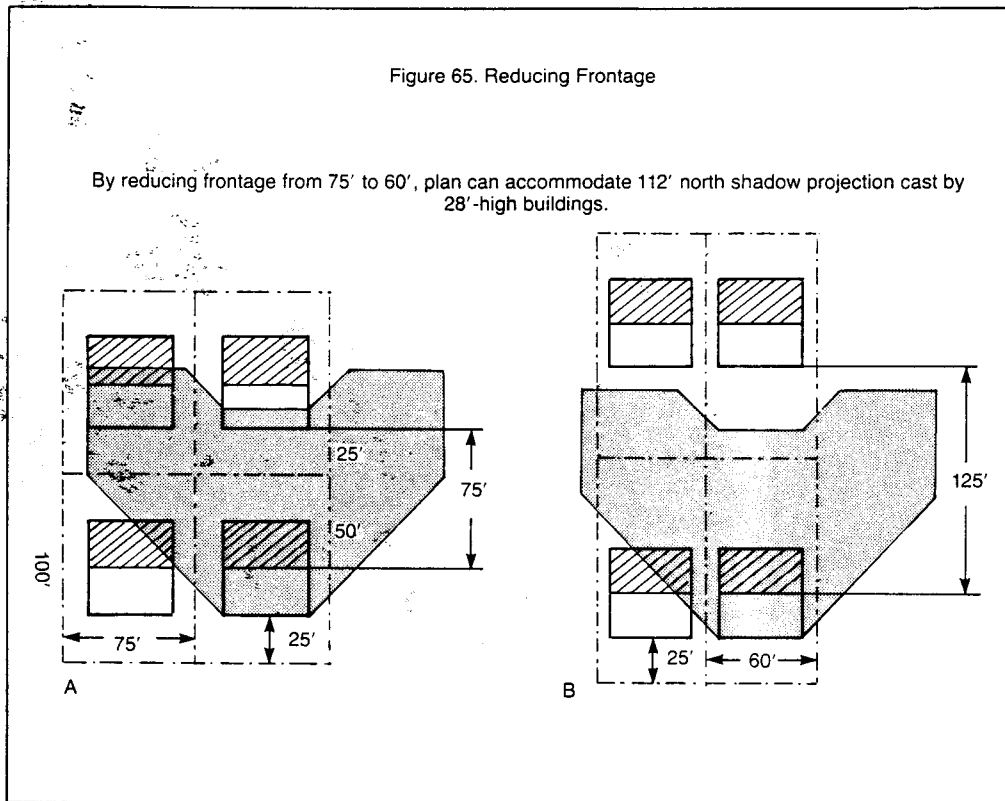

Figure 65. Reducing Frontage

By reducing frontage from 75' to 60', plan can accommodate 112' north shadow projection cast by 28'-high buildings.



SITE COMPONENTS

SC

Figure 69. Reducing Setback to Equalize Access

A. Traditional Setback and Unequal Access

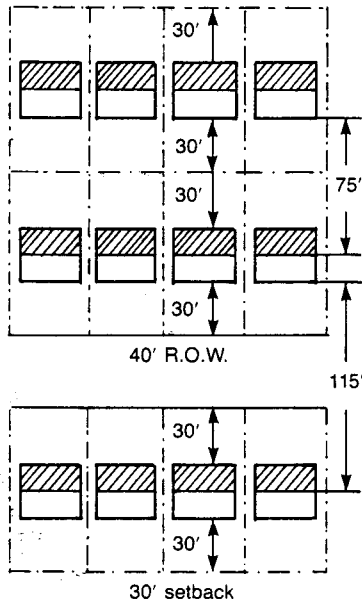

B. Reducing Setback to Equalize Access

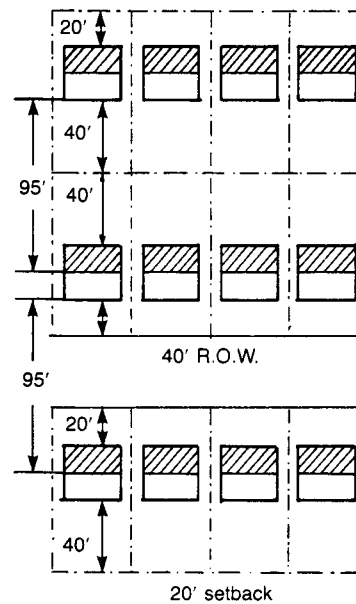

Hypothetical site, flat at 40°N. latitude, with a shadow projection of 87.5' for 25'-high buildings.
 In A, only buildings to the North of road right-of-way have south-wall access. By reducing setback by 10' (from 30' to 20'), all structures have south-wall access in B. This affects shading only by buildings; street trees must be regulated to prevent shading problems.

Water conservation and waste treatment : By 2030, municipal sewer and water systems will have long been overstrained. With approximately 5" - 8" per year of rainfall, and the greenhouse effect causing higher temperatures , water conservation is of utmost importance to the project design. This requires planning for collecting grey water, storing rain water in cisterns and ponds, and treating water for re-use. On-site waste water treatment facilities will have to be planned for the site utilizing an area of approximately 700 square feet of wetland for each family to treat grey water.

On-site sewage treatment facilities will ease the burden on municipal services and produce methane gas as a useable by-product. The methane gas can be used to heat a food producing greenhouse. This is already done on a large scale at landfills today. Composting material can be used to fertilize local community gardens at the project site.

SITE COMPONENTS

SC

COMMUNITY GARDENS

SINGLE FAMILY NEEDS FOR ALL VEGETABLES PER YEAR IS EQUAL TO 2,400 SF

SINGLE FAMILY NEEDS FOR GREENS ALONE IS EQUAL TO 1,200 SF

JEAVONS

THE MODULES ON THE RIGHT ARE EQUIVALENT A TOTAL OF 4 FAMILIES FULL VEGETABLES OR 8 FAMILIES GREENS ONLY

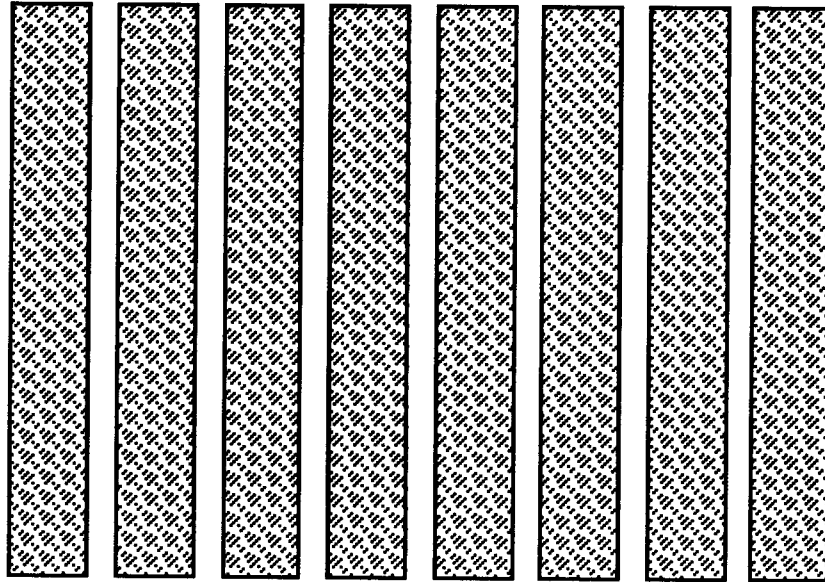

42' 6"

GREY WATER TREATMENT

EACH FAMILY REQUIRES APPROXIMATELY 700 SF OF WETLAND TO TREAT THEIR GREY WATER

SOURCE: WOLVERTON

35' 0"

THE AREA ON THE RIGHT IS APPROXIMATELY EQUIVALENT TO 5 FAMILIES

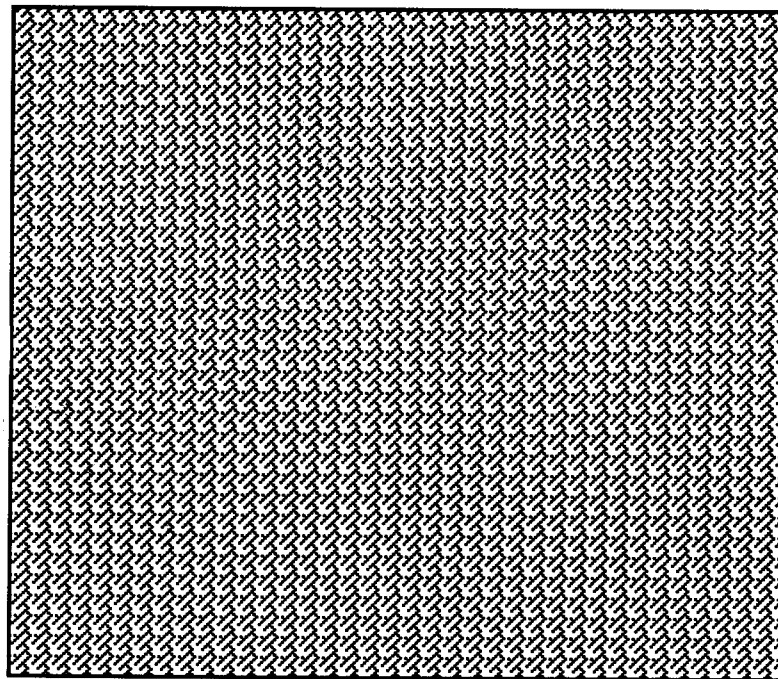

40' 0"

SITE COMPONENTS

SC

ON SITE WASTEWATER TREATMENT USING VERMICULTURE

TREATMENT - 1000 PER:
2000 LB RED WRIGGLER
WORMS TO TREAT SLUDGE
AT BETWEEN 54 AND 84
DEGREES, SLUDGE IS
DEWATERED

AREA:
1/6 ACRE FOR GREENHOUSE
1/10 ACR SLUDGE STORAGE
TANK
1/8 ACRE SLUDGE HANDLING

ADVANTAGES:
THIS METHOD OF TREATMENT WOULD
SAVE THE ENERGY COST OF AERATION
OR A TOTAL OF APPROXIMATELY
\$30,000 PER YEAR FOR A PLANT OF THIS
SCALE. IN ADDITION THE PLANT CAN SELL
WORMS AND CASTINGS AND BECOME A
SMALL BUT VIABLE ECONOMIC VENTURE.

DISADVANTAGES:
THERE HAVE ONLY BEEN A HANDFUL OF
VERMICULTURE PLANTS OPERATING IN THE
U.S., ONE ALSO SHOULD KNOW THAT THERE
IS A MARKET FOR BY-PRODUCT PRODUCTION

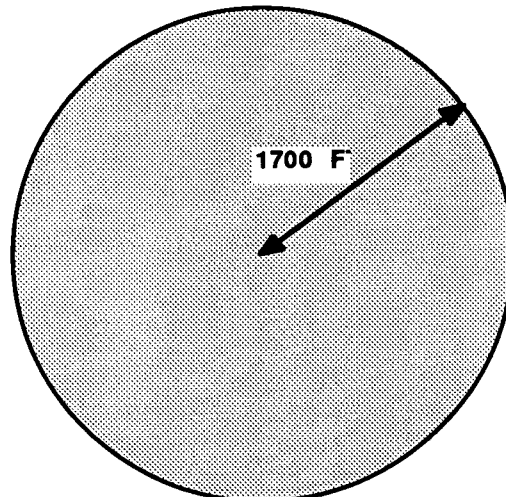
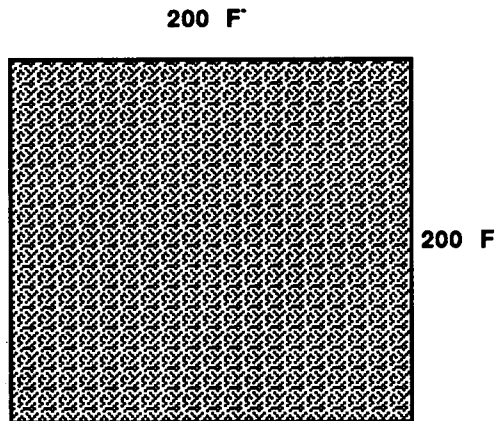
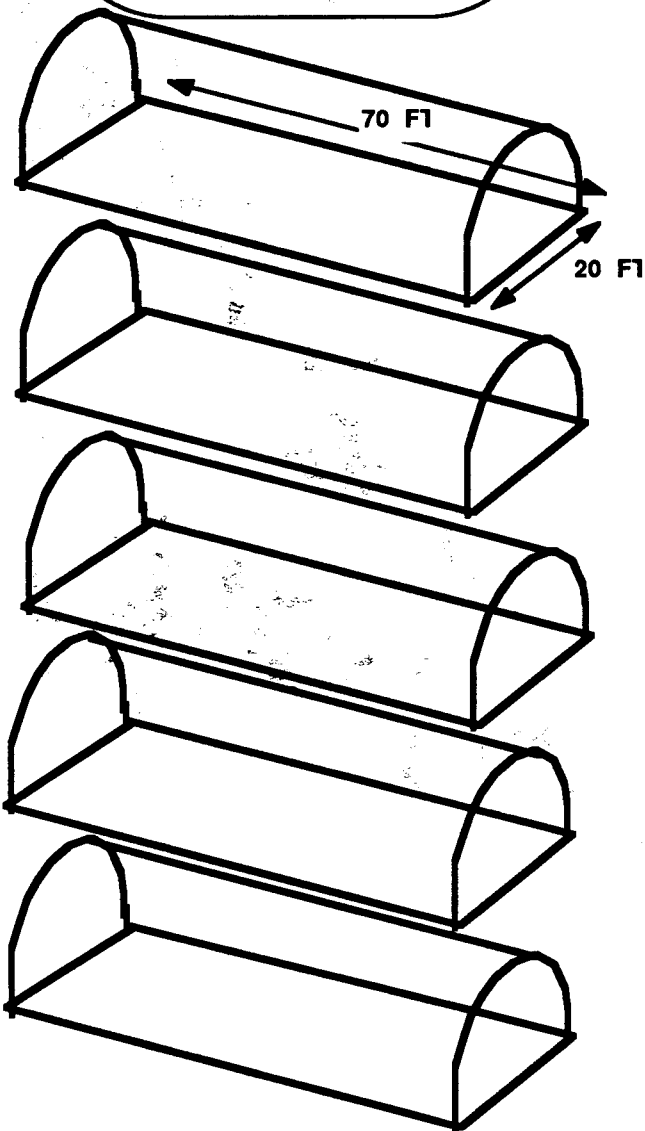

SITE COMPONENTS

SC

ON SITE SEWAGE TREATMENT - METHANE GAS PRODUCING SEWAGE TREATING GREENHOUSE

TREATMENT CAPACITY
4000 GAL/D SYSTEM
1 FAMILY OF FOUR
EQUALS 400 GAL/D
THIS SYSTEM EQUALS
10 FAMILIES

AREA

1 FAMILY EQUALS 200 SF
OF GREENHOUSE AND
PRODUCES 600-850 CF
OF BIOGAS THIS SYSTEM
REQUIRES A 2000 SF
GREENHOUSE AND PROVIDES
APPROXIMATELY 7000 CF
OR MILLION BTU'S OF
GAS - ENOUGH TO HEAT
THE GREENHOUSE WITH
EXCESS DURING SUMMER
MONTHS

ADVANTAGES:

PRODUCES METHANE GAS AS BY-PRODUCT
AS WELL AS HYACINTH PLANTS FOR GARDEN
COMPOST EVERY MONTH AND USES LESS
AREA THAN A WETLAND. IT IS ALSO LESS
INTENSIVE THAN A SEWAGE TREATMENT
PLANT.

DISADVANTAGES: DOES NOT OFFER A
NATURAL LANDSCAPE, NEEDS SOME
MAINTENANCE

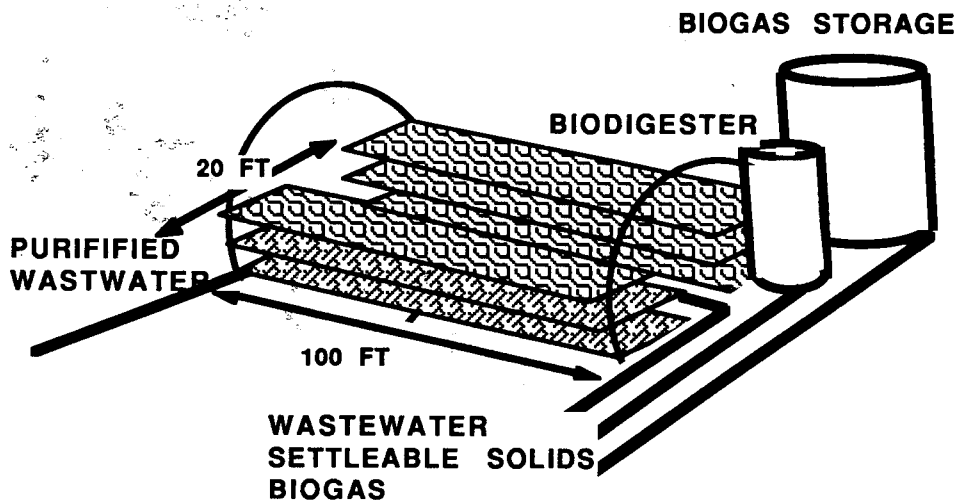

SITE COMPONENTS

SC

WETLAND SEWAGE TREATMENT

TREATMENT CAPACITY
1 MGD SYSTEM
1 FAMILY OF FOUR
EQUALS 400 GAL/D
THIS SYSTEM EQUALS
2500 FAMILIES

AREA
7 ACRE FRESH WATER
WETLAND (120 SF/FAM)
8.4 ACRE PEAT WETLAND
(144 SF/FAM)

SOURCE
LOMBARDO

ADVANTAGE:
TRANSFORMS THE USUAL TECHNOLOGICAL
APPROACH OF TREATING SEWAGE INTO AN
ATTRACTIVE LANDSCAPE FEATURE THAT
ATTRACTS WILDLIFE AND IS VERY LOW
IN ENERGY USE COMPARED TO MECHANICAL
MEANS

DISADVANTAGE:
USES CONSIDERABLE LAND. FOR EXAMPLE
A POPULATION OF 1000 PEOPLE ON TWENTY
ACRES WOULD REQUIRE 6.16 ACRES

FRESH WATER WETLAND AREA FOR 10 PEOPLE



PEAT WETLAND AREA FOR 10 PEOPLE



SITE COMPONENTS

SC

PONDS

Butyl is a synthetic rubber with outstanding waterproofing properties that make it ideal for creating natural-looking garden ponds and water features. We fabricate our liners from a superior grade of Swedish butyl rubber that has become the most favored liner for English water gardens. Unlike other synthetic rubbers—and some other butyls—these liners will not harm sensitive aquatic life.

Our butyl liners offer many advantages over other premium liners, such as those made from PVC, yet are only slightly more expensive. Compare these features:

- Our liners remain flexible at very cold temperatures so they won't become stiff and crack in a hard freeze.
- Our liners are very supple and elastic so they will conform to the curves and irregular surfaces of natural-looking ponds. In addition, their flat, jet-black color creates a more natural look than most plastics can achieve.
- Our liners have durable vulcanized seams that will remain watertight for the service life of the sheet.
- Our liners are warranted for 20 years against deterioration from weathering when installed properly.
- Our liners are also ideal for lining planter boxes, tile showers, and cisterns.

We stock the following standard sizes (to allow for sides and edges, order a liner approximately five feet larger in length and width than the finished pond size):

BL11.08	BUTYL LINER, 30 mil, 11' x 8'	BL16.27	BUTYL LINER, 30 mil, 16' x 27'
BL11.11	BUTYL LINER, 30 mil, 11' x 11'	BL22.22	BUTYL LINER, 30 mil, 22' x 22'
BL11.16	BUTYL LINER, 30 mil, 11' x 16'	BL22.27	BUTYL LINER, 30 mil, 22' x 27'
BL16.16	BUTYL LINER, 30 mil, 16' x 16'	BL22.33	BUTYL LINER, 30 mil, 22' x 33'
BL16.22	BUTYL LINER, 30 mil, 16' x 22'		

In addition, we can supply custom sizes by the foot, in almost any size (call for delivery times). For very large ponds, 40mil and 60 mil thickness is available.

BL05.01	BUTYL LINER, 30 mil, 5' 6" wide, per foot
BL11.01	BUTYL LINER, 30 mil, 11' wide, per foot
BL16.01	BUTYL LINER, 30 mil, 16' 6" wide, per foot
BL22.01	BUTYL LINER, 30 mil, 22' wide, per foot
BL27.01	BUTYL LINER, 30 mil, 27' 6" wide, per foot
BL33.01	BUTYL LINER, 30 mil, 33' wide, per foot
BL38.01	BUTYL LINER, 30 mil, 38' 6" wide, per foot
BL44.01	BUTYL LINER, 30 mil, 44' wide, per foot
BL49.01	BUTYL LINER, 30 mil, 49' 6" wide, per foot

Tears can be permanently repaired with a patch made from a scrap of rubber and a piece of Butyl Repair Tape. Repair tape can also be used to make field seams.

BL93.30	BUTYL REPAIR TAPE, 3" x 131'
BL93.31	BUTYL REPAIR TAPE, 3" wide, per foot

RESOURCE CONSERVATION TECHNOLOGY, INC.
2633 North Calvert Street Baltimore, MD 21218 (301) 366-1146

SITE COMPONENTS

SC

PEDESTRIAN PATHWAYS

BIKE PATHS

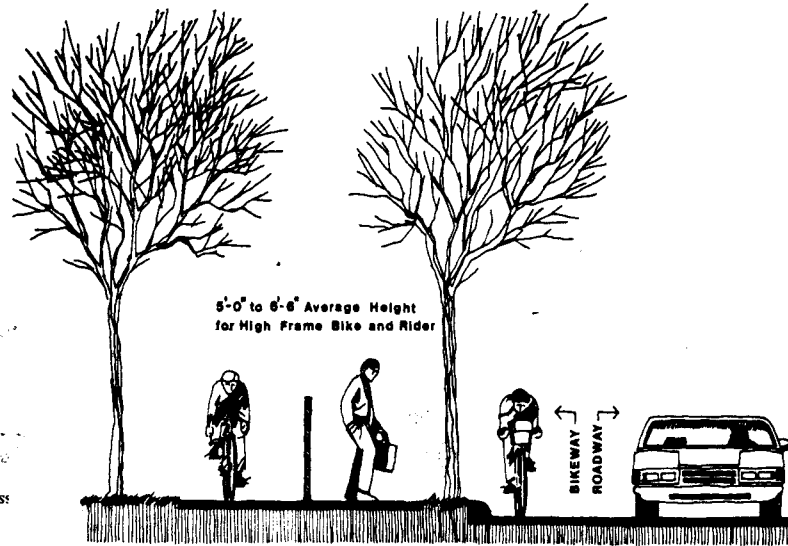
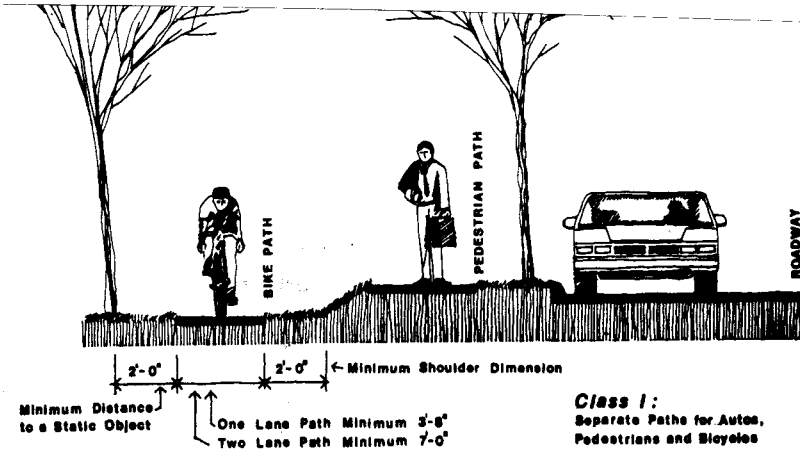

CLASS II: Total or Partial Separation.
Auto, Pedestrian and Bikeway Right-of-Way on Common Pavement

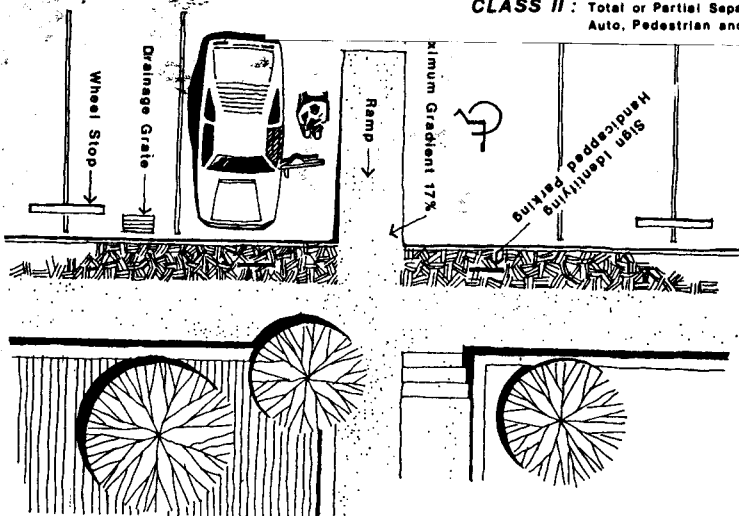

SITE COMPONENTS

SC

OFF STREET PARKING

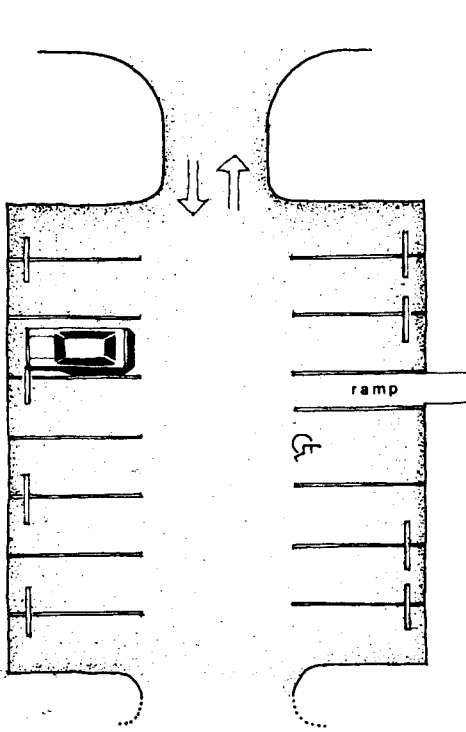

90° Parking

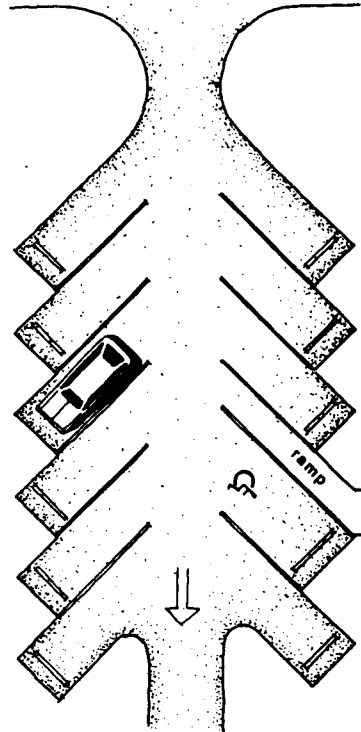

45° Parking

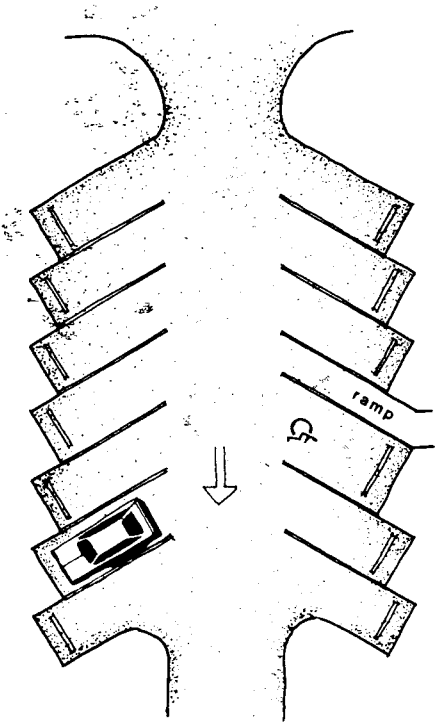

60° Parking

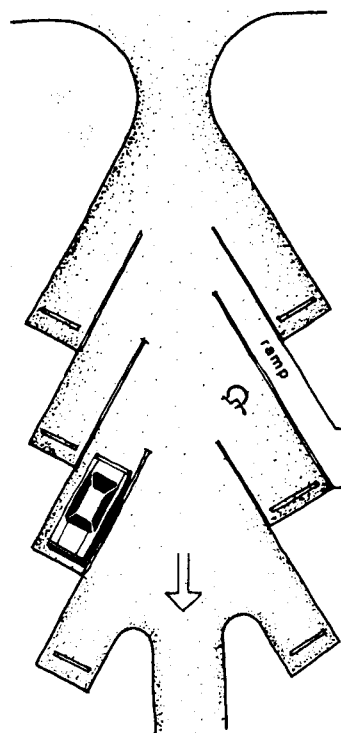

30° Parking

SITE COMPONENTS

SC

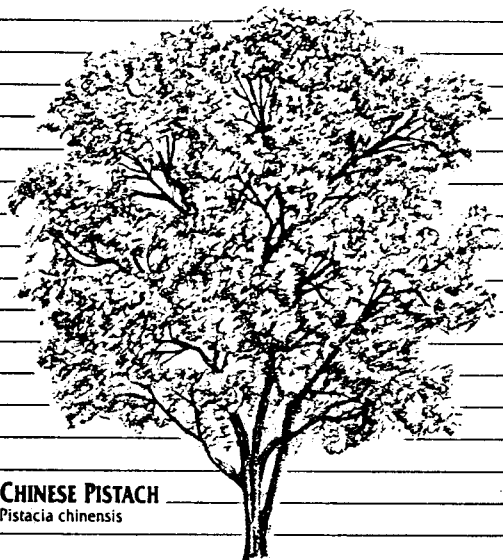

CHINESE PISTACH
Pistacia chinensis

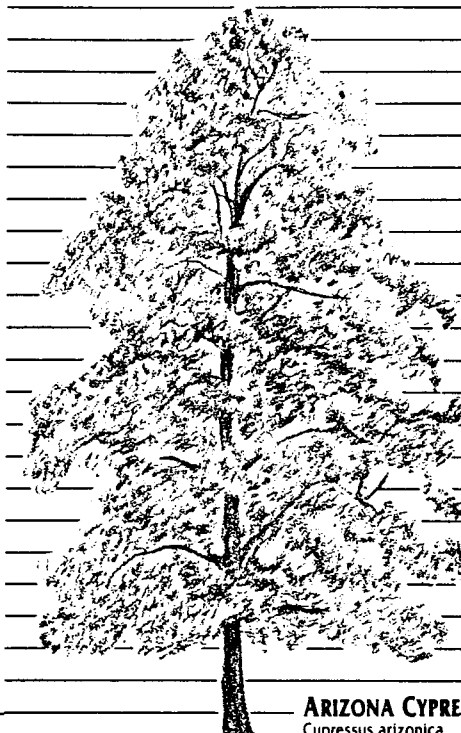

ARIZONA CYPRESS
Cupressus arizonica

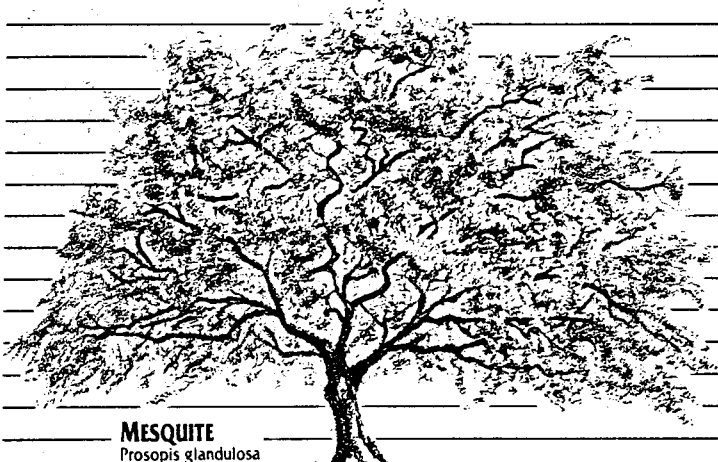

MESQUITE
Prosopis glandulosa

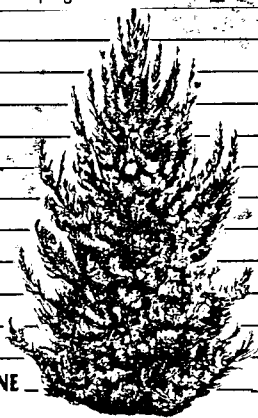

AFGHAN PINE
Pinus elderica

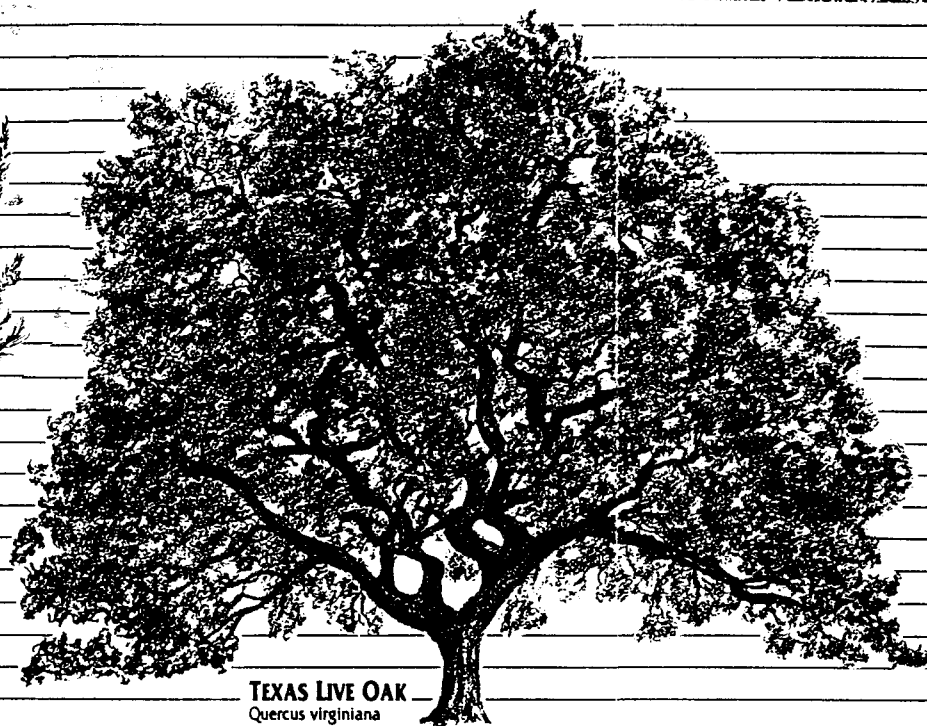

TEXAS LIVE OAK
Quercus virginiana

Tree Chart

Species	Evergreen	Deciduous	Spreading	Rounded	Pyramidal	Shrubby	Up to 25 feet	25 to 50 feet	50+	Small	Medium	Large	Slow	Moderate	Rapid	To 30 Years	30-50 Years	Over 50 Years	Moist	Moderate	Dry	Wildlife	Flower	Fall Color	Bark Texture/Color	Surface Roots	Freeze Damage	Brittle Wood	Fruit Drop	High Maintenance	Disease/Insects	Notes
Arizona Cypress <i>Cupressus arizonica</i>	●				●			●		●				●											●							Shiny foliage, interesting gnarled bark
Arizona Ash <i>Fraxinus velutina</i>		●																														Dense shade and high maintenance
Afghan Pine <i>Pinus eiderica</i>					●																											Fast growing, drought tolerant
Chinese Pistach <i>Pistacia chinensis</i>		●																														Brilliant red fall color seedless variety
Mesquite <i>Prosopis glandulosa</i>		●																														Light shade
Texas Live Oak <i>Quercus virginiana</i>		●																														Limit use to areas with low live oak - oak will disease a problem

SITE COMPONENTS

SC

SITE COMPONENTS

SC

SHADE

8' OR HIGHER CLEARANCE

FEATURES

- 1.9" dia. high-yield alloy steel
- Shade cloth 21% to 92%
- Rot and insect proof
- Simple, fast to erect
- 12'2" sq. modular sections

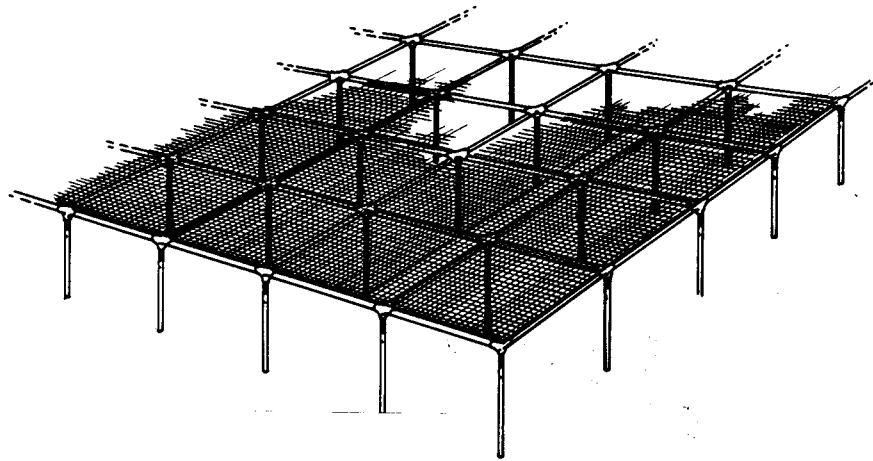

SITE COMPONENTS

SC

PRIVACY FENCES, NOISE CONTROL WIND PROTECTION

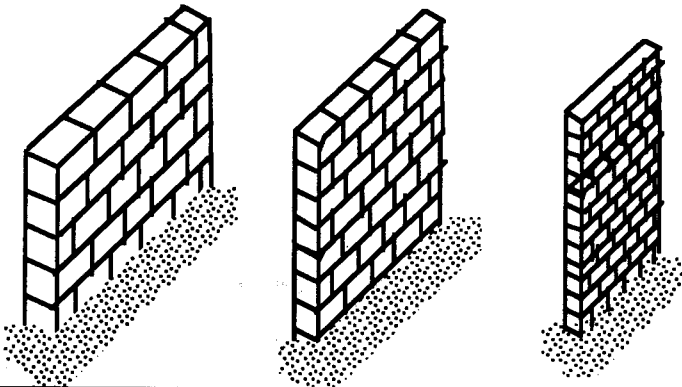

NOTE:

SIMPLE SITE COMPONENTS SUCH AS THE HUMAN SCALE BROUGHT ABOUT BY OUTSIDE AREAS DEFINED BY WALL SYSTEMS CAN MAKE OR THE QUALITY OF A SITE

STUCCOED
AGRICULTURAL
STRAW BY-
PRODUCTS

STUCCOED
ADOBE, CALICHE

STUCCOED
RAMMED
BLOCK

PAVING SYSTEMS

USES:
SIDEWALKS, DRIVEWAYS,
GARAGE FLOORS, PATIOS,
PLY AREAS, SPLASH
GUARDS UNDER HOUSE
EAVES, SHALLOW DRAIN-
AGE DITCHES

ATTRIBUTES:
INEXPENSIVE AND
ATTRACTIVE

MINUSES:
TAKES SOME SOIL MIX
TESTING AND REQUIRES
A MODICUM OF UPKEEP

USES:
THERE ARE VARIOUS TECH-
NIQUES OF USING RUBBER
AS A RECYCLED MATERIAL
IN PAVING. THERE ARE
POURED IN PLACE METHODS
AS WELL AS PAVER BLOCKS.

THIS METHOD IS GOOD FOR
PLAYGROUNDS, ENTRANCE
WAYS, LOADING AREAS,
ETC.

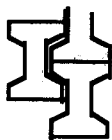

CARLISLE TIRE & RUBBER
BOX 99
CARLISLE, PA 17103

USES:
STRIKING PATTERNS IN
CONCRETE IS ANOTHER
LOW COST ATTRACTIVE
METHOD OF PAVING. AL-
THOUGH MORE EXPENSIVE
THAN OTHER METHODS IF
PROPERLY POSITIONED
AT STEPS OR ENTRANCES
AND PATHS ALONG DRIVES
IT IS FAR LESS EXPENSIVE
THSN USING DSEPARATE
TILES AND ONE CAN MAKE
THE STAMPS OF MANY
USING METAL AND PRESS
ING THE CONCRETE WITH
PLASTIC SHEET BETWEEN
THE PRESS AND THE WET
CONCRETE ---SEE SPECS



SOIL CEMENT

RECYCLED MATERIALS

PATTERNED FLYASH
CONCRETE

THE LIVING REALM

The Grid

We have opted for a column, beam, and plank framing system, rather than a bearing wall system, for the structural building components of the industrialized house. It is borrowed with permission from Neal Mitchell, whose system has already proven successful in the U.S. and other countries. The column and beam system allows for greater flexibility in the design of the dwelling. Exterior and interior walls and partitions can be easily removed, replaced, and relocated without changing the building's structure. Even the perimeter walls can be allowed to be free from the roof and irregular in pattern, since they are non-load bearing materials and easily related to indigenous earth building practices. The walls, doors, and windows can be replaced by newer, more efficient units in the future. The structure endures, but the infill may soon be out of date requiring us to make it removable.

If the walls are non-bearing, they are more likely to be lightweight and easily handled by one or two people. This system offers the potential homeowners the option of contracting the framing work and completing much of the remaining work themselves. Perhaps one firm equipped for larger scale construction could be employed to complete the framework, while separate, smaller, firms or craftsmen could provide the enclosure and finishes. We believe that this system offers the greatest amount of diversity and forms of expression by the future inhabitants.

The origin of the grid arose out of the need to standardize the structural and "infill" building components. However, we did not want technical or structural criteria alone to govern the layouts of rooms and the dimensions of all these components. As we are concerned with a rather small structure - a single family residence attached to other like residences - we were certain that the structural problems were easily solvable with a number of different materials. In fact, we assumed at the outset that most of the load bearing components of the system - columns, beams, and planks - could be fabricated into light weight, easily handled parts. Instead of asking ourselves, "What is the maximum span of a 2x10 joist or a laminated wood beam?" to determine the dimensions of the grid, we asked ourselves "What is the minimum volume we require for comfortable habitation?"

Of course, the answer to that question will vary depending upon what in particular we are doing at the time. Sleeping requires less space than preparing a meal. Bathing, dressing, eating, and playing all require a different amount of space. Instead of conducting a study in ergonomics by analyzing *each* of these activities in isolation, we asked ourselves what is the minimum volume that can house *all* of these activities. The answer is different than just the sum of the areas required for each activity separately. Cannot we sit and sleep on the same piece of furniture? Can

we entertain in the same room where we work? Can a shower, lavatory, and toilet be incorporated into one fixture? Can a water heater and refrigerator be combined into one appliance? In the year 2030, the answer to all of these questions may be yes. In fact, these furnishings and appliances exist today, but most are available only at exorbitant costs. Without assuming too many technological breakthroughs or economic miracles, clues to the answers exist in much of the current effort to solve the problems of affordable housing and homelessness.

Recent housing projects in the form of single room occupancy (SRO) "residential hotels" have attempted to address the need to provide homes for single adults with little income.

Documentation of rooms and furniture in existing SRO hotels generated many criteria to be considered in developing future prototypes for room size and layout. Recent projects have deviated from the approach to designing compact, minimum, "machine for living" spaces, and have recognized the need to consider as equally important the non-tangible personal and social requirements of comfortable living. Daylighting, "defensible space", privacy, and opportunity for social interaction are all important criteria for design. Of course, all this must be provided inexpensively, for most SRO projects work under the constraints of a modest budget.

With these ideas in mind, several types and sizes of SRO rooms have been designed. All include the basic activities of sleeping, eating, sitting, reading, working, and storage. Some include full or half bathrooms and some also include kitchenettes. In his recent research, Michael Mostoller has designated six items that are assumed to be essential to daily life even in the most modest of circumstances.

Bed : sitting, reading, eating, watching TV as well as sleeping.

Wardrobe : clothes storage, mirror.

Table : eating, working, socializing.

Chair(s) : sitting at and away from the table.

Stand : storage of personal items.

Sink cabinet : assuming other bath facilities are shared.

Mostoller then investigated a series of room sizes and shapes to fulfill critical design criteria.

Accommodate the six basic furnishings without becoming overcrowded or cramped.

Promote the zoning of activities in the room.

Allow for alternate arrangement of furnishings.

Minimize organizational, operational, and visual problems.

Mostoller studied various room proportions and areas, varying dimensions from 8 feet to 16 feet. He states that for an 8 foot by 8 foot room, "there is almost no room to move about and the use of furniture will be severely constrained.... The 8 foot by 10 foot room... while constricted in size,

does allow for a minimum level of comfort and could be acceptable under emergency conditions." Two room sizes, 8 foot by 12 foot and 10 foot by 10 foot, each approximately 100 square feet, provide a greater feeling of spaciousness and accommodate all generic furniture arrangements. Furthermore, each room can be organized into a socializing and work area, a dressing and storage zone, and a bed area. This arrangement "creates an internal order to the room that is commendable."

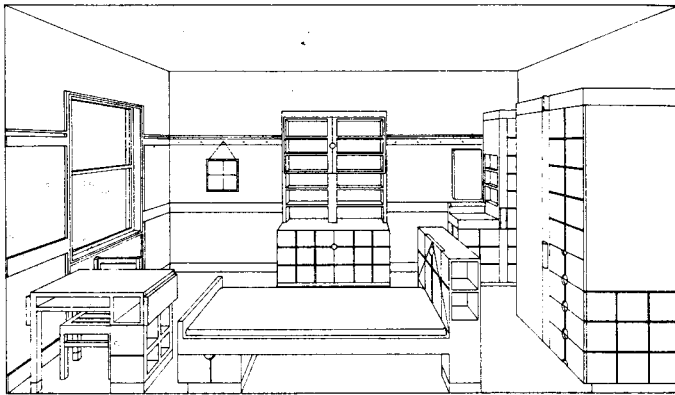
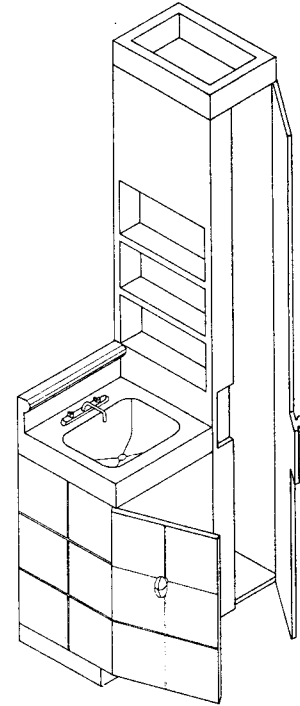

Figure 13-16. The prototype room with furniture: view across the room, showing storage cabinet in place of stand.



Mostoller's prototype SRO design, with furniture, viewed from across the room, and one of the furniture pieces.

No new arrangements of furnishings emerge when the room is increased to 10 feet by 12 feet, although a larger bed and storage area are possible. Likewise, a 12 foot by 12 foot room adds square footage without improving efficiency, creating different arrangements of furnishings, or improving zoning. (Note : Bunk beds, loft beds, or Murphy beds were not considered.) Mostoller goes on to recommend a rectangular shape over a square shape, due to the fact that it creates a "longer visual focus" and more opportunities for multiple use of furnishings. He also correctly points out that for small rooms a high ceiling will do much to increase the perception of spaciousness. A room height between 9 and 10 feet is recommended.

Other contemporary studies have supported these conclusions. Recent SRO hotels and affordable housing for the elderly both here and abroad have presented the 100 - 120 square foot "one room scheme." Using some of the proposed building components presented in this study, it is possible to provide a "bathing module," mini - kitchenette, and the furnishings described above all in an area of 100-120 sq. ft.

Based upon this information, we developed the 10 foot by 10 foot (3 meter by 3 meter) living module as the basic unit of the grid. This is the minimum "comfortable" room size. We also agree with the concept of higher ceilings to increase the perception of spaciousness, and propose a ceiling height of 9 to 10 feet (3 meters + or -). We knew however, that the grid needed to be more than a series of 10 foot cubes arranged horizontally and vertically (although we wanted to keep this option possible). If all columns are spaced at 10 feet (3m), then all the rooms are likely to end up at 10 feet (3m). There were other options we wanted to design into the system.

First, limiting the size of all rooms to 10 feet (3m) in width seemed too restrictive. Although 10 foot by 20 foot (3m by 6m) and 10 foot by 30 foot (3m by 9m) rooms would be possible, some rooms require 12 foot (3.6m) or more in width. As stated earlier, a small rectangular room may function better and feel more spacious than a small square room. Rooms of rectangular shape with one side greater than 10 feet (3m) should be made possible within the grid.

Our other concern was the need to create areas between rooms. Halls, stairs, and entries are usually required in order to travel from one room to the next without passing through any other room. Although some rooms can be used as circulation routes (e.g., living areas, dining areas, and kitchens), others require separation for privacy (e.g., bedrooms and bathrooms). The grid had to provide "zones" between rooms of varying sizes so that the problems of circulation within the house could be resolved. These zones could also be available for each room to be modified and expanded.

All of these options are made possible by surrounding each 10 foot by 10 foot (3m by 3m) room with a 3 foot 4 inch (1m) wide perimeter area. This perimeter area serves many purposes. Internally, it allows for larger size rooms where desired. It varies the spacing of the columns in both directions allowing the plan of each room to be different. Although all the columns are spaced at multiples of 1 meter, the various spacings provide the option of creating a larger room with no freestanding columns in the room. The largest square room without columns can now be 13 feet 4 inches (4m) square. (This assumes that the structural spans can be increased from 3m to 4m.) The largest rectangular room without columns can be 13 feet 4 inches (4m) wide along the entire length of the dwelling.

INSERT HERE PRELIMINARY GRID PLANS (3mx3m)

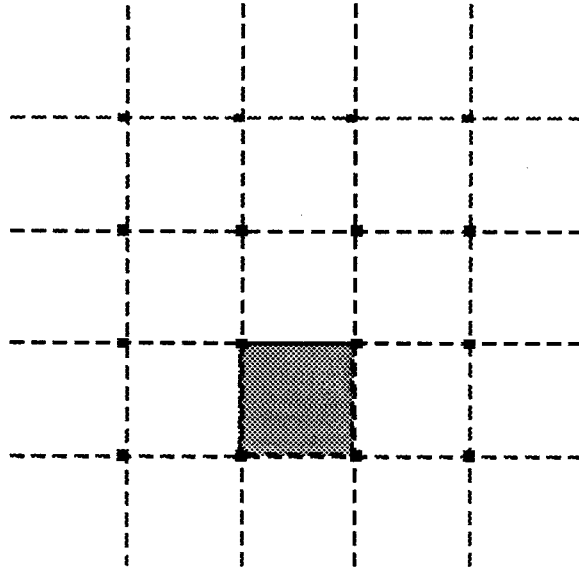

3m

A 10 foot by 10 foot (3 meter by 3 meter) grid.

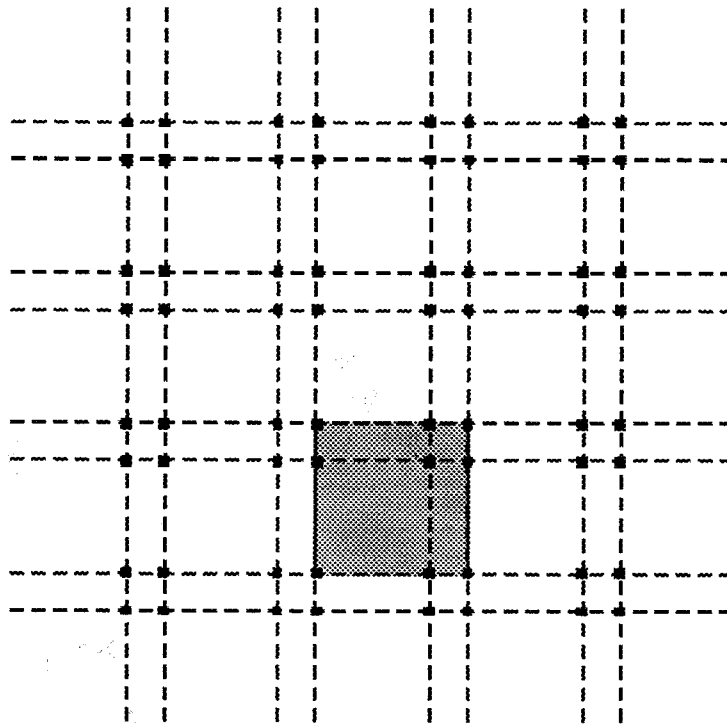

4m

Each 10 foot (3m) square surrounded by a 1m perimeter.

The 1m width creates enough space for halls, stairs, and closets between rooms without having to travel through rooms or use space within the room for storage. Horizontal and vertical circulation can occur on any or all of the four sides of each room. Both internally and externally, the extra 1m creates the possibility of expanding the size of any room in all four directions. A room that starts out being 3m by 3m can be potentially expanded to 4m by 4m without modifying any other rooms (except for closets, halls, etc.).

This 1 meter wide room perimeter is further divided into 1 meter long segments. This subdivision serves two purposes. First, a 3m or 4m wide room can be located anywhere along the width and length of the grid. Two or more rooms of equal width can also be easily joined together. Secondly, individual living modules of various lengths can be located along the perimeter of any room. These modules are 1m wide and vary in length from 1m to 3m (possibly to 5m or more). These modules contain such spaces as half baths, kitchenettes, sleeping alcoves, media centers, and storage areas.

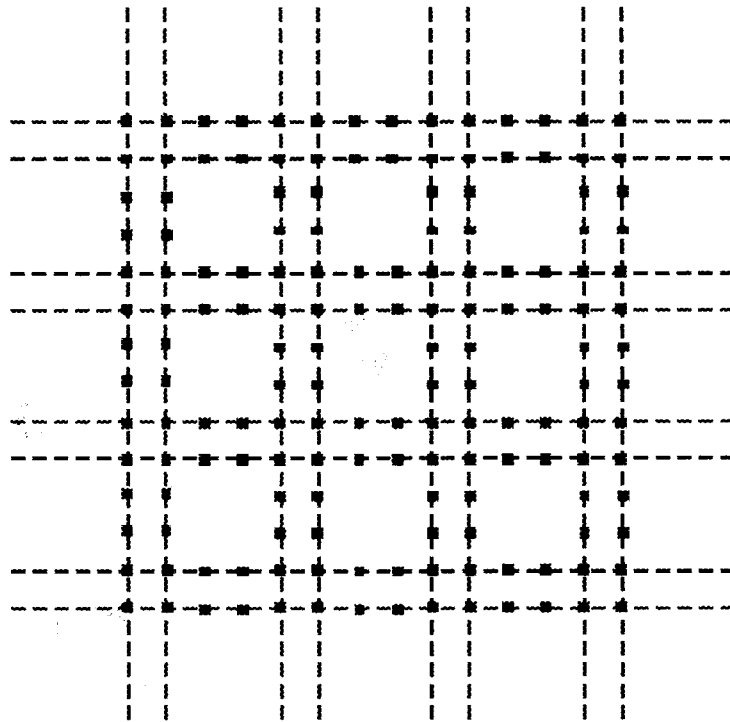

The 1m wide perimeter is subdivided into 1m squares.
This defines all possible column locations.

Each grid plan therefore is based on a 10 foot (3 meter) square room surrounded by a 3 foot 4 inch (1 meter) wide perimeter. The number and placement of these units will vary with site, building program, and housing type. This proposal focuses on a multi-family attached "starter house" of approximately 800 square feet (72 square meters) able to be expanded by at least 300 square feet (27 square meters). Using these areas as a guide, we proposed a plan that would allow each homeowner to double the size of the "starter house" and still preserve some private, semi-enclosed open space adjacent to it. Accordingly, we developed grid plans for dwelling units that can be expanded up to 2,000 square feet (180 square meters) including areas to be preserved for outdoor living.

Using these areas as a guideline, we developed a grid plan for one, two, and three story units. One story units may be reserved for elderly or physically challenged residents. They will have a good "ground connection," potentially good solar orientation, and maximum exposed roof area for solar and daylighting options, but will require more exterior wall area for enclosure than a more compact unit.

The two story units have a smaller site footprint and offer better views, potential ventilation, and privacy zoning than the one story units. Home offices and work rooms can be more widely separated from private living spaces by vertical zoning. A room or two rented to an unrelated adult tenant can also be separated vertically from family areas. Roof terraces can be created for outdoor living above ground by stacking the rooms in various arrangements.

The three story units will have the smallest site footprint and the least amount of roof area. The third floor location provides options for views, daylighting, ventilation, and privacy not offered in the other units. Excellent solar exposure can be attained by the upper living space. Vertical zoning of work or rental space, common space, and private space becomes possible.

Units higher than three stories were not included in this proposal. At that height, the area required for vertical circulation becomes a significant fraction of the total area of 800 square feet. We also assumed that local zoning regulations would limit the height of dwellings to three stories or 35 feet. Solar envelope concepts and solar access possibilities also limited the height of the units to three stories or approximately 30 feet.

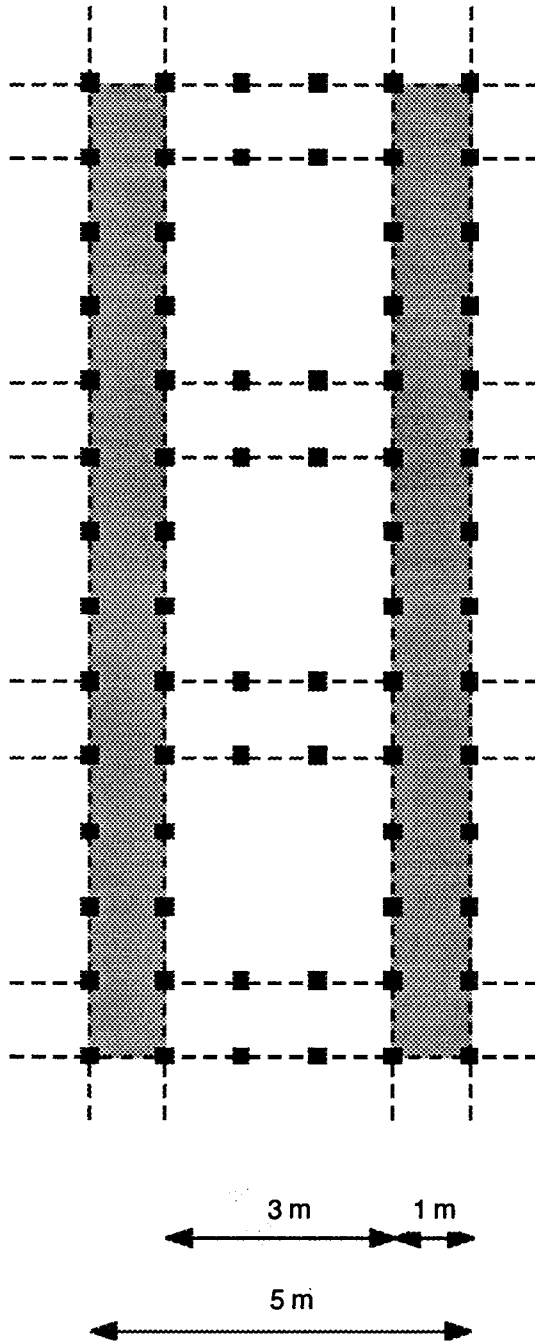

Grid plan for a three story unit. The two shaded perimeter areas are adjacent to other units. This layout defines 3 spatial units, 10 bay units, and 8 corner units per story, including perimeters. The columns and beams may be laid out in any pattern along the ground and stacked to a maximum height of four stories. The volumes defined will be determined by the following formulas :

Number of spatial volumes = [bays - corners] + 1.
 Number of bay volumes = [spaces + corners] - 1.
 Number of corners = [bays - spaces] + 1.

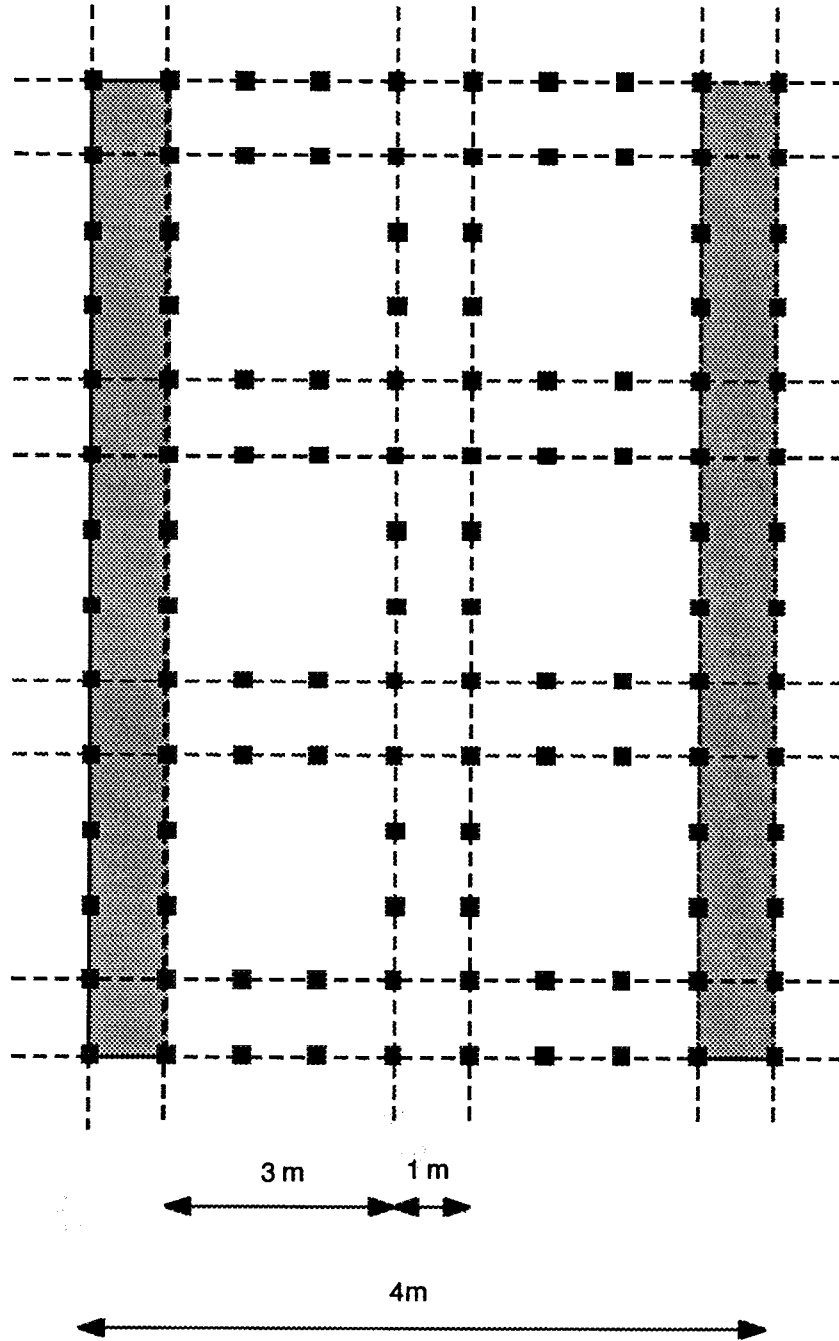

Grid used for a two story unit. The shaded perimeter areas are adjacent to other units. The layout defines 6 spatial units, 17 bay units, and 12 corner units per story, including perimeters.

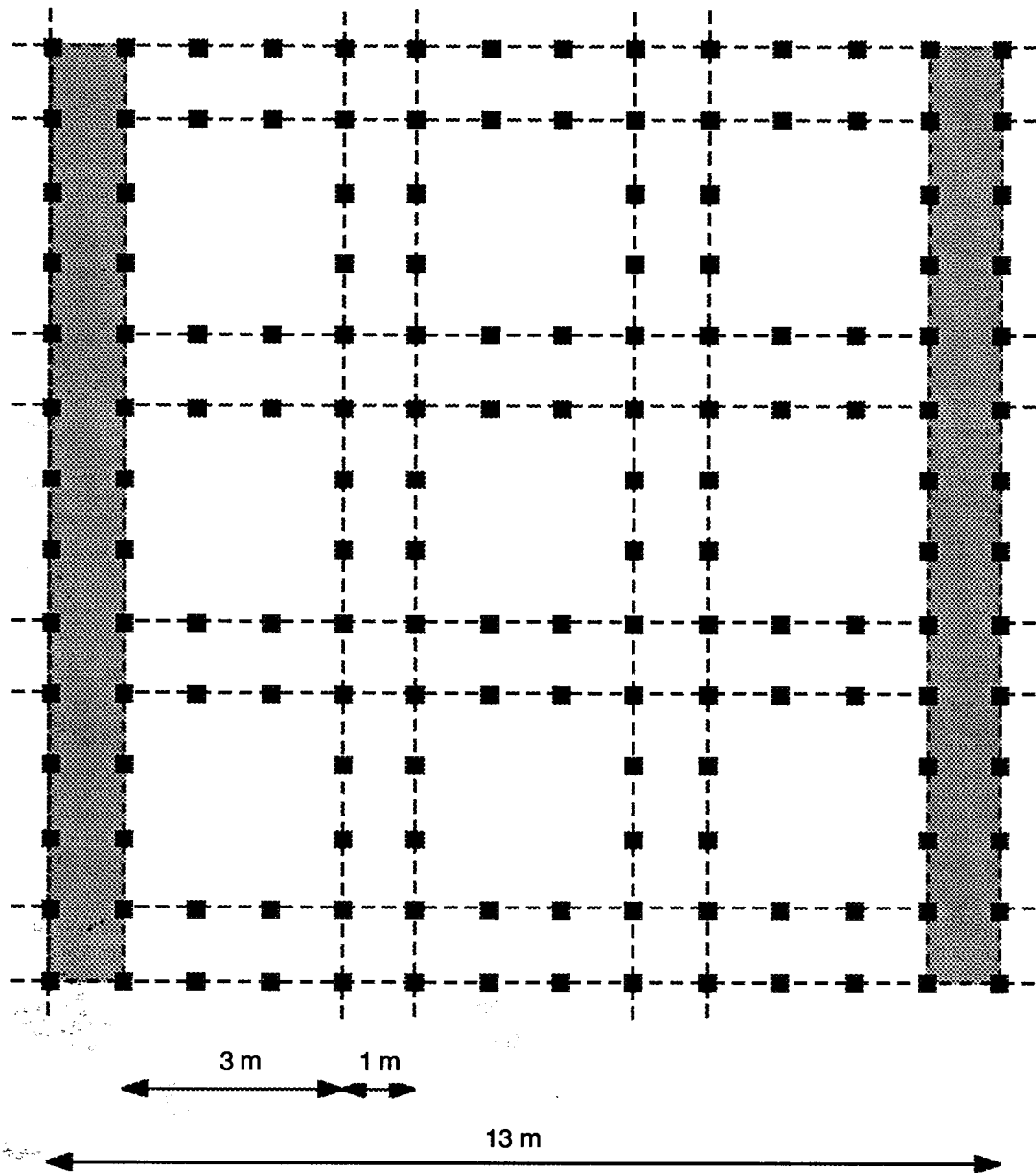

Grid plan for a one story unit. The two shaded perimeter areas are adjacent to other units. This layout defines 9 spatial units, 24 bay units, and 16 corner units, including perimeters. The columns are erected on concrete post footings to form a 3 meter by 3 meter structural bay. The 3 meter span may be increased to 4.5 meters.
 (From a system developed by Neal B. Mitchell, Jr., Harvard University, 1967.)

LIVING AREA

LA

SINGLE ADD-ON SPACE

SMALL CLOSET / PANTRY
OVER UNDER WASHER
DRYER
EFFICIENCY BATHROOM
GARDEN/LAWN EQUIP STOR.
SHOWER
WATER HEATER, BOILER, FURNACE

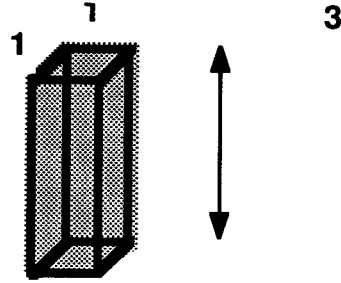

DOUBLE ADD-ON SPACE

BED NOOK
DOUBLE BUNK
CLOSET
EFFICIENCY KITCHEN
ENTERTAINMENT
CENTER
WINDOW SEAT
LAUNDRY
GAME ALCOVE

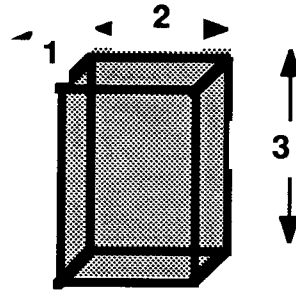

TRIPLE ADD-ON SPACE

STAIR WELL
HALL
LARGE CLOSET
LINEAR KITCHEN
ATTACHED GREENHOUSE

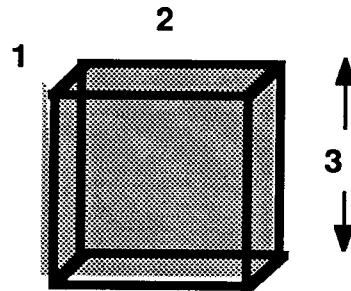

LIVING AREA

LA

MULTI-STORY SINGLE ADD-ON

SPIRAL STAIR
SMALL ELEVATOR
DUMB WAITER
HEARTH
COOLING
CHIMNEYS

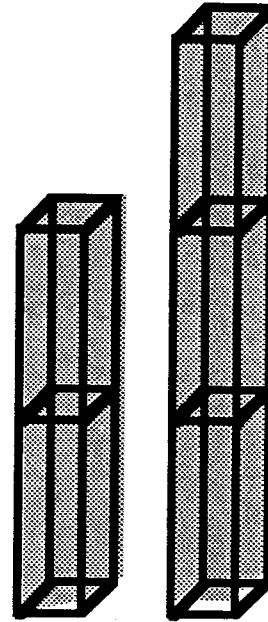

MULTI-STORY TRIPLE ADD-ON

STACKED UTILITIES
STAIRS
UP AND DOWN DRAFT
COOLING TOWERS

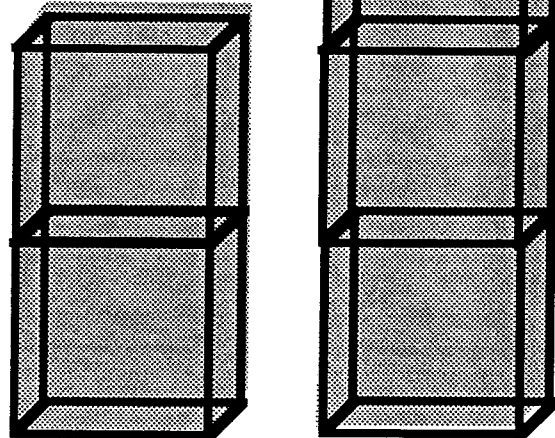

LIVING AREA

LA

FRAME STRUCTURE

CARPORT
TRELLIS
SMALL SHELTER
BUS STOP SHELTER

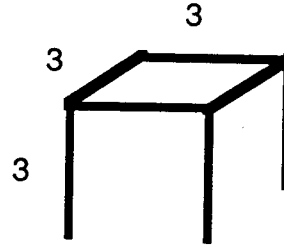

SINGLE FILLED-IN FRAME STRUCTURE

OUTSIDE OFFICE
OUTSIDE REC ROOM
OUTSIDE TEENAGE
BEDROOM
CLUB HOUSE

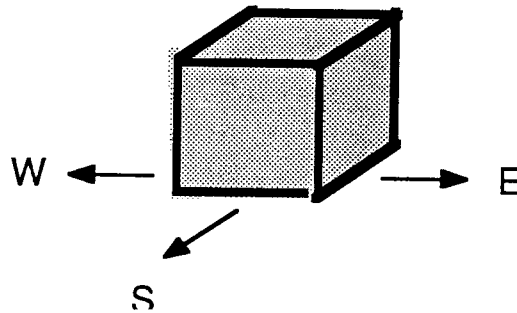

FRAME STRUCTURE ON TOP AND/OR ON SIDE OF SINGLE FILL-IN

OUTSIDE OFFICE
OUTSIDE REC ROOM
OUTSIDE TEENAGE
BEDROOM
CLUB HOUSE

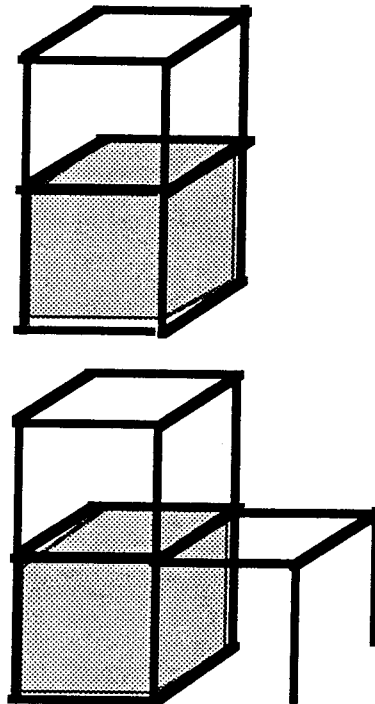

LIVING AREA

LA

DOUBLE FRAME WALLED

GOOD SOLAR ORIENTATION

- a TEENAGERS COTTAGE
- b GRANDPERANT'S APT.
- c STUDIO / EFFICIENCY
- d

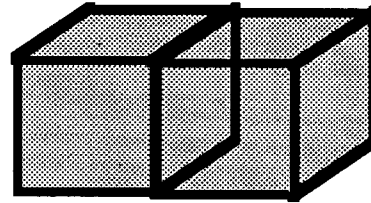

POOR SOLAR ORIENTATION MUST SHADE EAST AND WEST WALL AND USE HEATED APPLIANCES ON NORTH UNIT

- a TEENAGERS COTTAGE
- b GRANDPERANT'S APT.
- c STUDIO / EFFICIENCY
- d

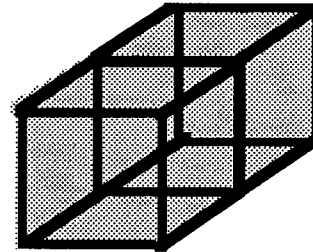

MEDIOCRE SOLAR ORIENTATION' AND GOOD PRIVACY GOOD BREEZE IN UPPER UNIT

- a TEENAGERS COTTAGE
- b GRANDPERANT'S APT.
- c STUDIO / EFFICIENCY
- d

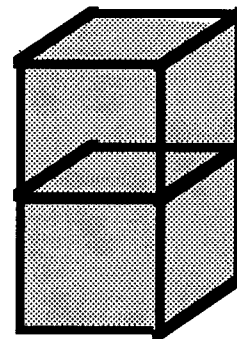

LIVING AREA

LA

3 UNITS PLACED IN A EAST TO WEST ORIENTATION ARE CONVENIENT SPACIALLY AND PROVIDE GOOD SOLAR ORIENTATION TO ALL UNITS

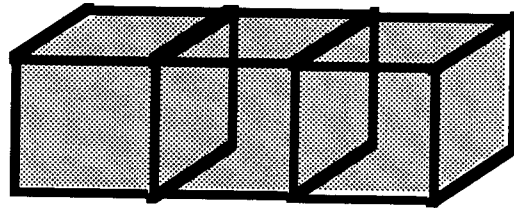

THREE 100 SF CUBES EAST-WEST

3 UNITS PLACED IN A NORTH TO SOUTH ORIENTATION ARE CONVENIENT SPACIALLY BUT ONE HAS TO REMEMBER THE HIGH POTENTIAL HEAT GAIN ON THE EAST AND WEST EXPOSURES

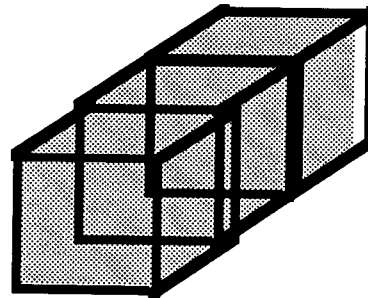

THREE 100 SF CUBES NORTH-SOUTH

WHEN SEPARATING STORIES ONE ABOVE THE OTHER EVEN A SMALL HOUSE 12 BY 12 CAN OFFER EXCELLENT PRIVACY AND GOOD SOLAR EXPOSURE

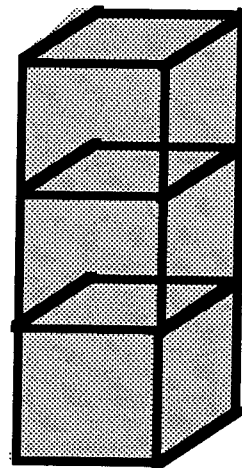

THREE 100 SF CUBES VERTICAL

LIVING AREA

LA

OPEN SPACE TO THE NORTHEAST PROVIDES POTENTIALLY HOT MORNING AND COOL AFTER-NOON POTENTIALLY HIGH HEAT GAIN ON THE WEST WALL

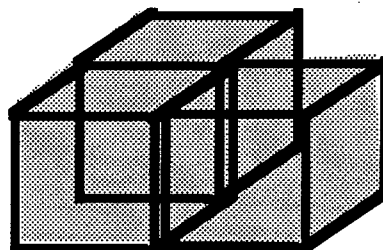

GROUND FLOOR OPEN SPACE TO THE NORTHWEST OFFERS COOL MORNING AND POTENTIALLY HOT AFTERNOON 2 UNITS RECEIVE HIGH MORNING HEATGAIN

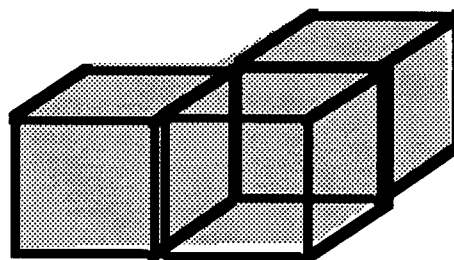

GROUND FLOOR OPEN SPACE TO THE WEST PROVIDES GOOD MID-DAY AND AFTER-NOON SUN EAST SIDE RECEIVES HIGH MORNING HEAT GAIN

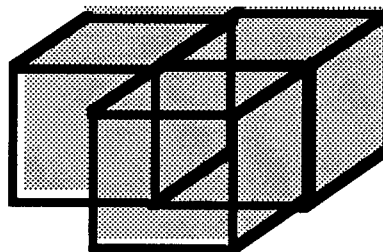

GROUND FLOOR OPEN SPACE TO THE EAST PROVIDES GOOD MORNING AND MID DAY SUN WEST SIDE RECEIVES HIGH AFTERNOON HEAT GAIN

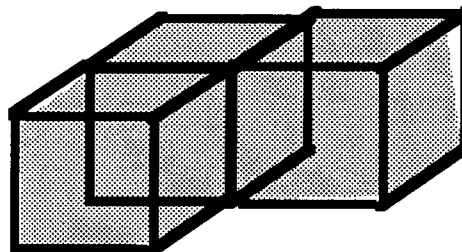

LIVING AREA

LA

**L STACK TO THE EAST
PROVIDES EARLY MORN-
AND MID DAY TERRACE
SUN
ALL 3 UNITS RECEIVE
GOOD WINTER SUN**

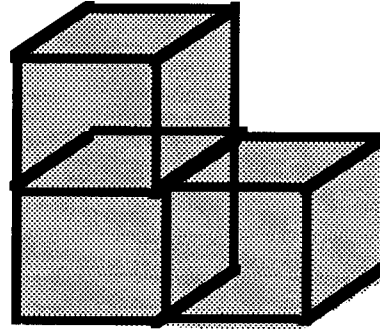

**THE L STACK WITH THE
TERRACE FACING WEST
PROVIDES AFTERNOON
SUN AND GOOD WINTER
EXPOSURE TO ALL THREE
UNITS**

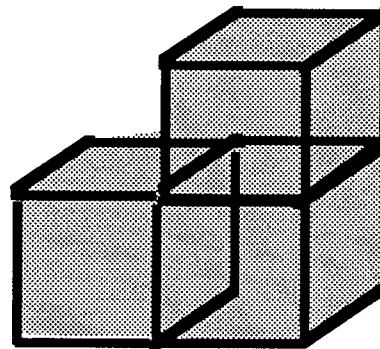

**3 UNITS STEPPED UP
TO THE NORTH PROVIDES
GOOD SOUTHERN EXPOSURE
TO BOTH THE TERRACE
AND TWO UNITS**

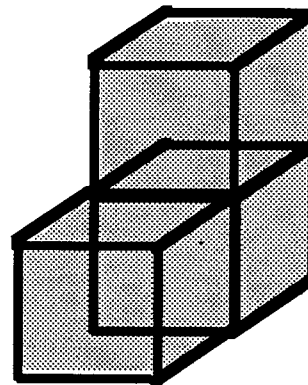

**HIGH SUMMER HEAT GAIN
ON EAST AND WEST**

**3 UNITS WITH TERRACE
AND ONE UNIT ON THE
NORTH SIDE
DOUBLE STORY ON THE
SOUTH PROVIDES GOOD
WINTER SUN**

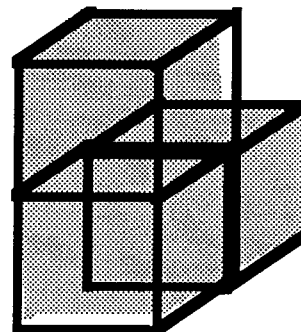

**HIGH SUMMER HEAT GAIN
ON EAST AND WEST**

LIVING AREA

LA

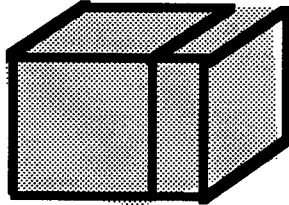
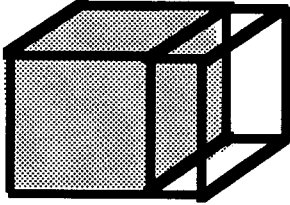

**RULE:
BASE UNIT
CANNOT BE
ADDED ONTO
ON BOTH SIDES
WITH 1 X 3
SPATIAL
ADDITION**

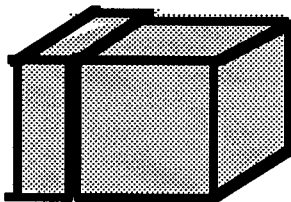
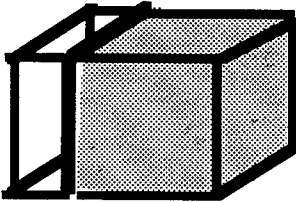

**1 X 3
COLUME
BEAM
ADDITION**

**1 X 3
SPATIAL
ADDITION**

**DOUBLE 1 X 3 UNITS
ACTING AS PARTY
WALL**

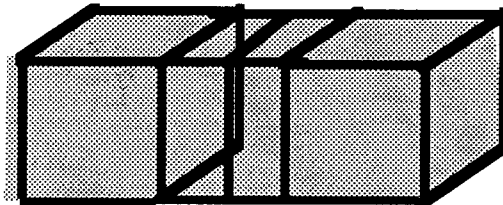

**SHOWS SINGLE
UNIT BEING ADDED
TO SINGLE UNIT
WHICH CAN THEN
HAVE 1 X 3 UNIT
ATTACHED**

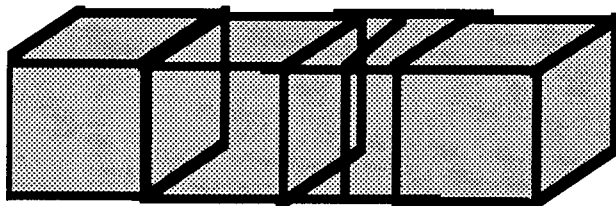



MINI-BATH



WASHER & DRYER



PANTRY



SHOWER



HEAT PUMP
WATER
HEATER



CLOSET
CABINET



ELEVATOR
DUMBWAITER



FIREPLACE



COOLING
TOWER



STAIR LANDING



DOOR
OVERHANG



DESK NOOK

Some examples of 1 meter by 1 meter modules.



HALF BATH



WALK - IN
CLOSET



CLOSET/CABINET

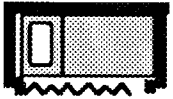

BED ALCOVE

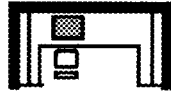

HOME OFFICE

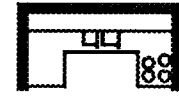

KITCHENETTE



LAUNDRY

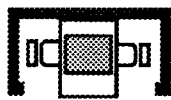

GAME/DESK
ALCOVE

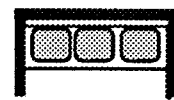

WINDOW SEAT



MECHANICAL

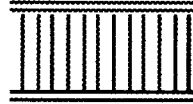

LOFT
STAIRS



RECYCLING BINS

Examples of 1m by 1m and 1m by 2m modules that can be added to any room or built into the 1m wide perimeter surrounding each room.



STAIRS



HALLWAYS



EXTRA ROOM



HEARTH

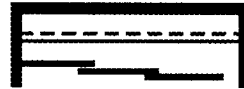

CLOSET / CABINET



LINEAR KITCHEN

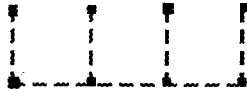

SHADE STRUCTURE



UTILITY ROOM



HOME OFFICE



MEDIA CENTER



PASS THRU CLOSET

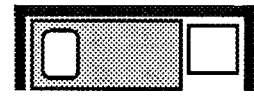

BED WITH DRESSER



SINGLE ROOM WALL UNIT



EFFICIENCY BATHROOM



WATER TREATMENT SYSTEM



SOLAR HEAT STORAGE

Examples of 1 meter by 3 meter modules that can be built into rooms or perimeters.

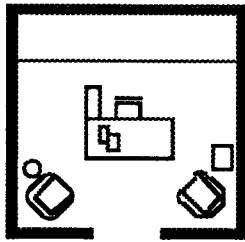

HOME BUSINESS

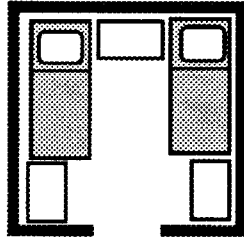

BEDROOM

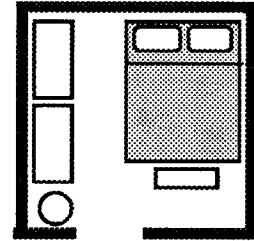

BEDROOM

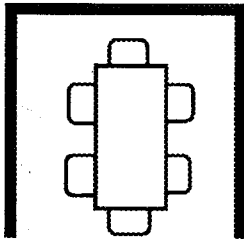

DINING ROOM

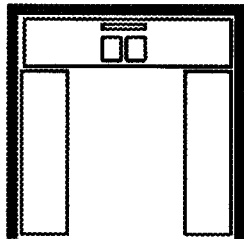

KITCHEN

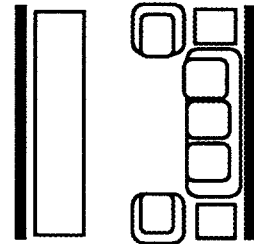

LIVING

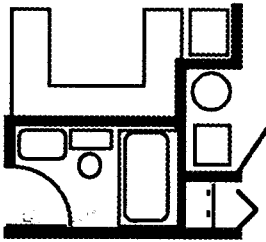

MECHANICAL CORE

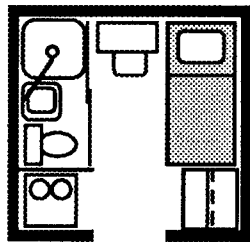

SINGLE ROOM LIVING

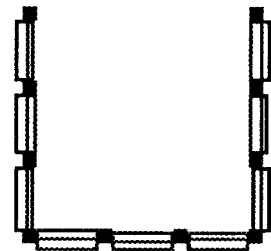

SUNSPACE

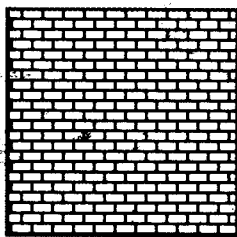

PATIO

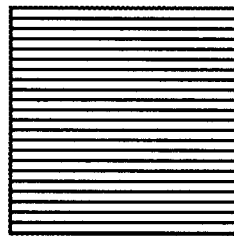

ROOF TERRACE

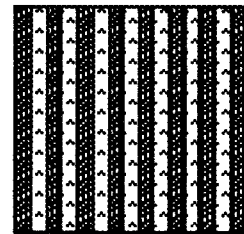

GARDEN

Examples of 3 meter by 3 meter (10 foot by 10 foot) living spaces.

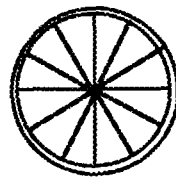
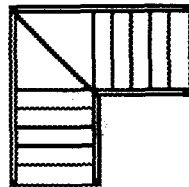
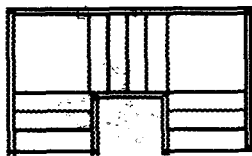
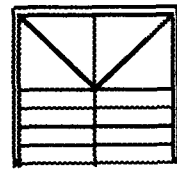
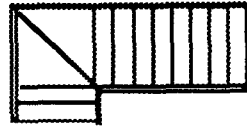
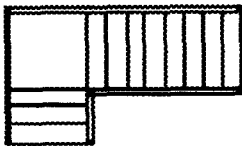
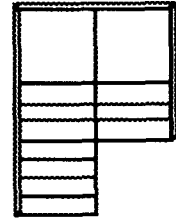
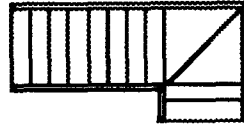
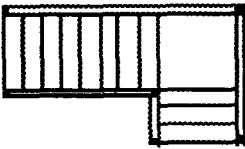
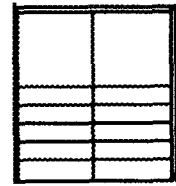
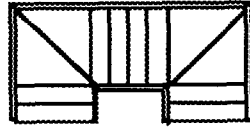
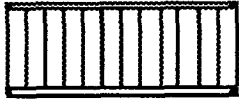

Stair options that fit into the grid.

PLAN DESIGN CRITERIA

Our first reaction to the building program presented in the proposal was to locate many different housing clusters throughout the site. Six to twelve dwellings would be attached to form each cluster and would be a mix of one, two, and three story units. The clusters may be arranged in straight or staggered rows depending on site vegetation, access roads, and pedestrian paths. Each cluster is built within its own solar envelope and has maximum potential solar access while not shading units to the north.

Three different types of units - one, two, and three story - help avoid the construction of monolithic housing projects. Each dwelling unit can start out at 100 square feet and grow to 1,800 square feet or more within its own "footprint." One story units expand horizontally at ground level, three story units expand up, and two story units expand in both directions. Through a self-regulating pattern, density of units will vary within the site. Some units will be made very compact, while others will be left almost detached.

Homeowners purchase a specific dwelling site within a cluster. Each site in the cluster is assigned a type of dwelling unit, with three story units in the center, one story units at the perimeter, and two story units in between. The maximum buildable footprint of the three story is 3 room units, of the two story 6 room units, and for the one story, 9. The three story unit can be expanded to 9 room units, the two story expanded to 12, and the one story to 9. The cost of each dwelling site varies with footprint size maximum potential house size. Homeowners purchase their site based upon location, potential size, and budget criteria and are asked to follow one simple rule: they can develop all but one of their site room units. This room is to be made flexible according to the choice of you and your neighbor. Some people may need a home office, while others may want to connect to an adjacent room of a relative or neighbor or create a shared courtyard. These interchangeable rooms are to connect with the public parts of each dwelling, living room, hall, or courtyards. For three story dwelling units, these "extra rooms" could even be connected to 2 or 3 others creating a large communal space.

Flexibility : In order to develop each dwelling according to the needs and wishes of the homeowner, flexible construction systems must allow for future additions, interior remodeling, and alterations between separate units. The proposed column and beam construction system allows the construction of outside additions. and the removal, relocation, and replacement of walls, doors, and windows without altering the structure. The flexible room agreement allow rooms to be exchanged between dwellings on either side. This system leaves spaces which can

be taken over, thus preventing residents from feeling boxed in. They can negotiate for an adjacent room, expand within their own footprint, and "get away" in shared common space. They can make the additions or changes themselves or with local contractors and craftsmen. The house cluster accepts extensions front, back, and up, evolving over time into its final form.

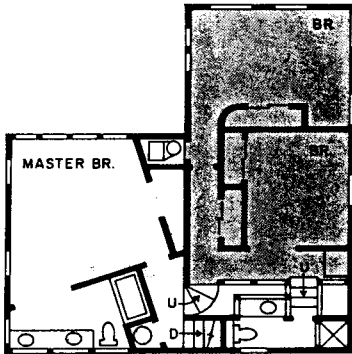

MASTER AND TWO BEDROOMS.

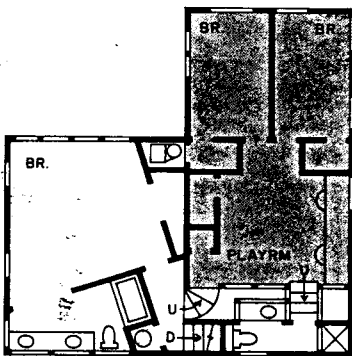

THREE BEDROOMS AND A PLAYROOM

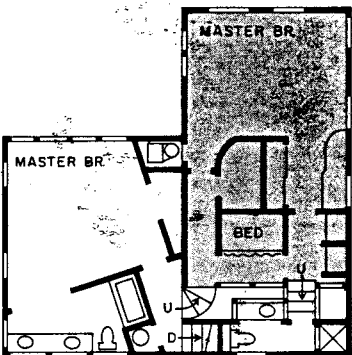

TWO MASTER BEDROOM SUITES

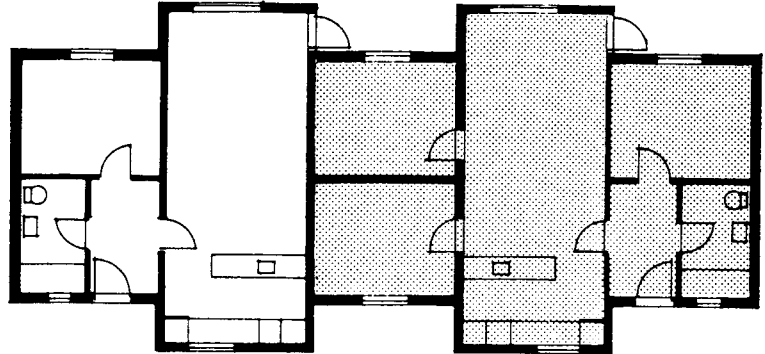

Young Couple

Couple with Older Children

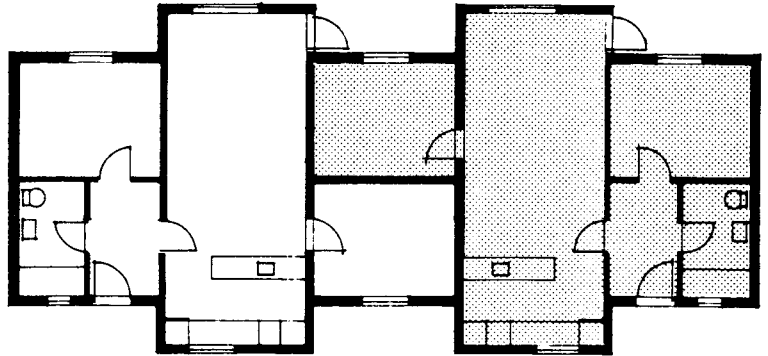

Couple with Young Child

Teenager Leaves Home

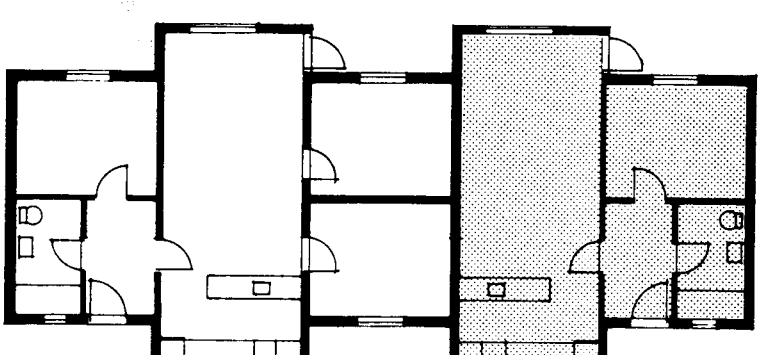

Couple with Older Children

Retired Couple

Flexible space within a dwelling unit (left, Smith & Others, architects) and between units (right, co-housing).

Transitional spaces : Each dwelling unit is designed with a hierarchy of spaces from private to public. This allows residents to choose how private or public they want to be at any given time. Generally, the kitchen-dining areas are located to face into common areas. One can observe the activities in the commons while attending to domestic activities. A parent can watch a child at play or call out to a passing neighbor. This casual surveillance is also a form of building security. Public rooms share adjacent outdoor living space. More private areas such as bedrooms look out onto private courts and gardens.

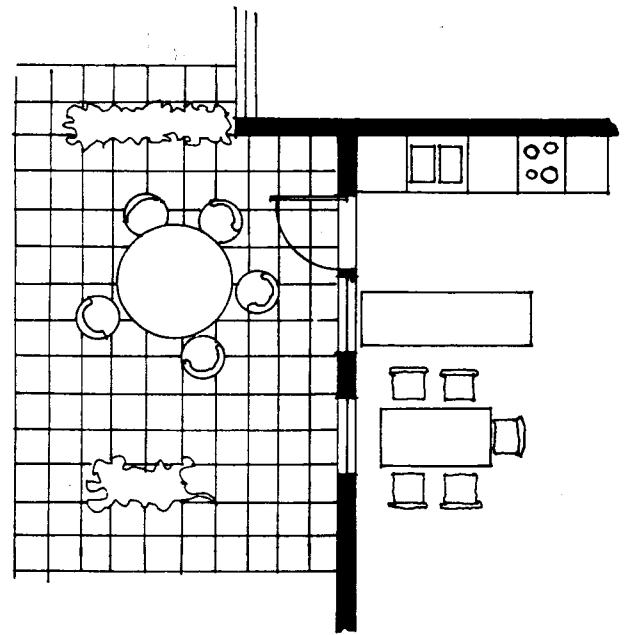
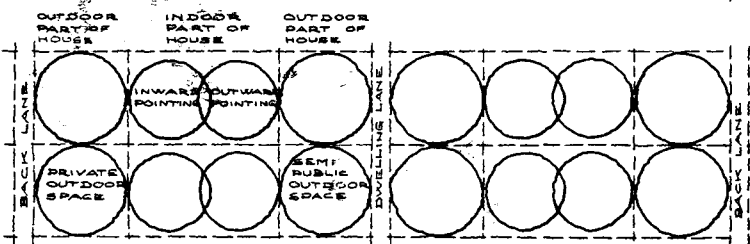
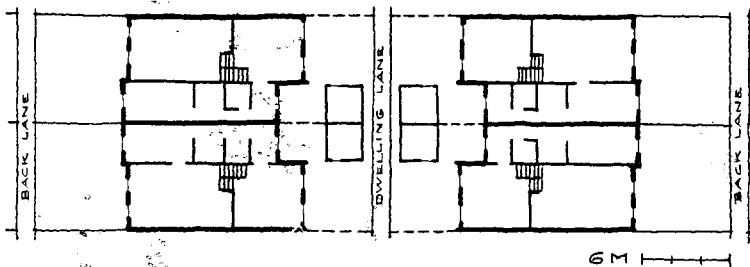
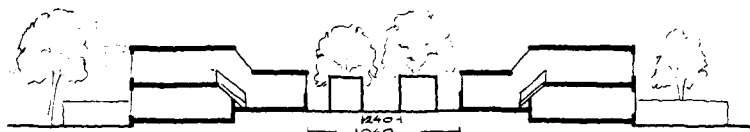
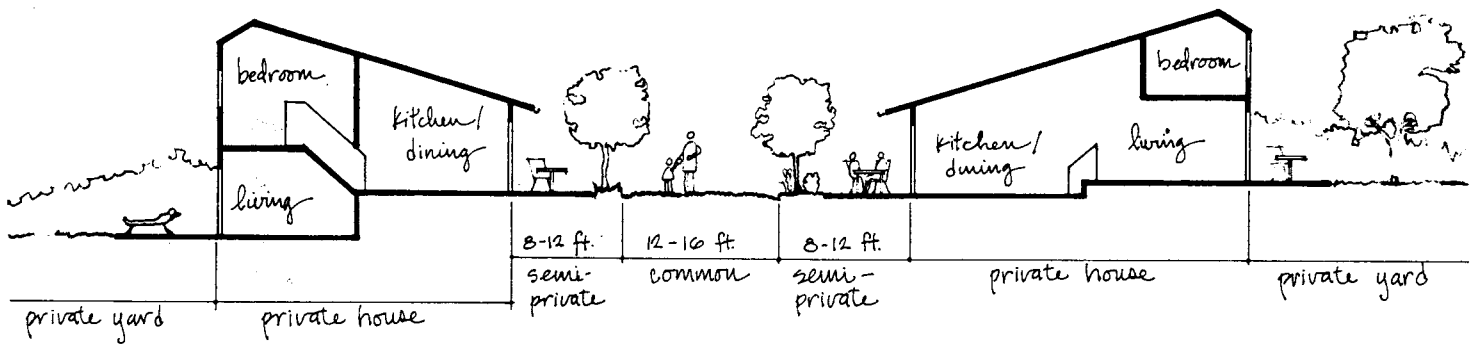

Active living spaces look out onto common areas. Provide an accessible "indoor-outdoor" connection.

House layout and systems: Each dwelling unit in a house cluster may be laid out in an east-west or north-south orientation. When attached, units laid out in the north-south orientation share more common wall area than in the other direction. The east-west orientation provides more solar access for the two and three story units, but the house cluster has a longer building footprint. We assumed that for economy of construction and maintenance, and the preservation of site features, that the units are arranged in typical "row house" fashion with the longer walls designed as common walls and shorter walls oriented north-south (except for the one story unit). Despite this limitation, each dwelling unit is designed as a long, thin house with daylighting and solar access provided to many rooms by the use of courtyards, shared light wells, and skylites.

In small buildings, don't cluster all the rooms together around each other; instead string out the rooms one after another, so that distance between each room is as great as it can be. You can do this horizontally—so that the plan becomes a thin, long rectangle; or you can do it vertically—so that the building becomes a tall narrow tower. In either case, the building can be surprisingly narrow and still work—8, 10, and 12 feet are all quite possible.

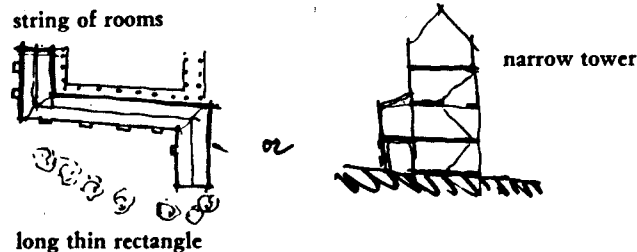

Home office spaces are located on the ground floor allowing potential business clients easy access without entering private spaces. A room rented out to another adult may also be located on the ground floor or separated in some other way from the private family spaces. Each unit is arranged so that either the kitchen-dining area or the major living area have a southern exposure. The master bedroom is also located facing south in most plans. The area of the south exposure is equal to one third of the floor area of each dwelling. After framing, structure, railings, etc., this will adequately allow for a south facing glazing area of 15%. Thermal mass is located in floors, walls, and optional mass walls. (The insulation is applied on the exterior side of the thermal mass.)

Roof terraces (for flat roofs) and gable or hipped roof, provide a surface area of 33% - 100% of the units floor area. These surfaces accommodate solar water heaters and photovoltaics. Flat roof designs can incorporate roof pond passive heating and cooling systems. Other units must rely on direct gain, mass wall, and sunspace solar systems.

NUMBER OF SPATIAL UNITS

DWELLING DESCRIPTION	1	2	3	4	5	6	7	8
TEMPORARY QUARTERS	●	●						
TEENAGER'S COTTAGE	●	●						
GRANDPARENT'S APARTMENT		●	●	●				
STUDIO / EFFICIENCY		●	●	●				
EFFICIENCY WITH EXTRA ROOM			●	●	●			
ONE BEDROOM			●	●	●			
ONE BEDROOM WITH EXTRA ROOM				●	●	●		
TWO BEDROOM				●	●	●		
TWO BEDROOM WITH EXTRA ROOM					●	●	●	
THREE BEDROOM					●	●	●	
THREE BEDROOM WITH EXTRA ROOM						●	●	●

House selection chart presents the homebuyers with options for different sizes and types.

PLAN PORTFOLIO

The following portfolio presents designs by ourselves and others that fulfill all the site, layout, and building system criteria set out in this proposal. Our plans are designed according to the criteria outlined in the proposal statement. We assumed that all three residency scenarios - adult couple with in-home clerical business, an adult couple with 2 children, and 1 adult with 2 children with a second unrelated adult tenant - could be accommodated in each and every dwelling.

Chronologically, the designs illustrate the same two adults first living together with a home business, then remodelling the same dwelling for two children. After a divorce, one of these adults stays with the children and rents out a room to an adult tenant. Each plan can expand and be remodelled for these life style changes. Some of the plans can accommodate the changes within the same building footprint, while others require additional living spaces. The sequences for the latter conditions help to illustrate how each dwelling can grow from a very small, compact design to a maximum allowable sized residence.

Designs by others that are appropriate to the proposed building system are also presented. The Building Mart of the future will offer designs by other local architects for customers to choose. Although every design does not follow the chronological sequence of life-style changes described above, they do fit well into the multi-family attached house cluster we have been proposing. Each design presents other housing options that should be included in the project - houses for one person, for couples without home businesses, and for other small families.

The ground floor plan of a three story unit is shown first with a home office, and then with additions and interior remodeling to accommodate two children in that same space. The master bedroom was also expanded at the same time. Entry is from the south, although a north entry (on the other side of the stairs) is also possible. Living, dining, and kitchen spaces are located on top floors for better solar access, views and privacy zoning.

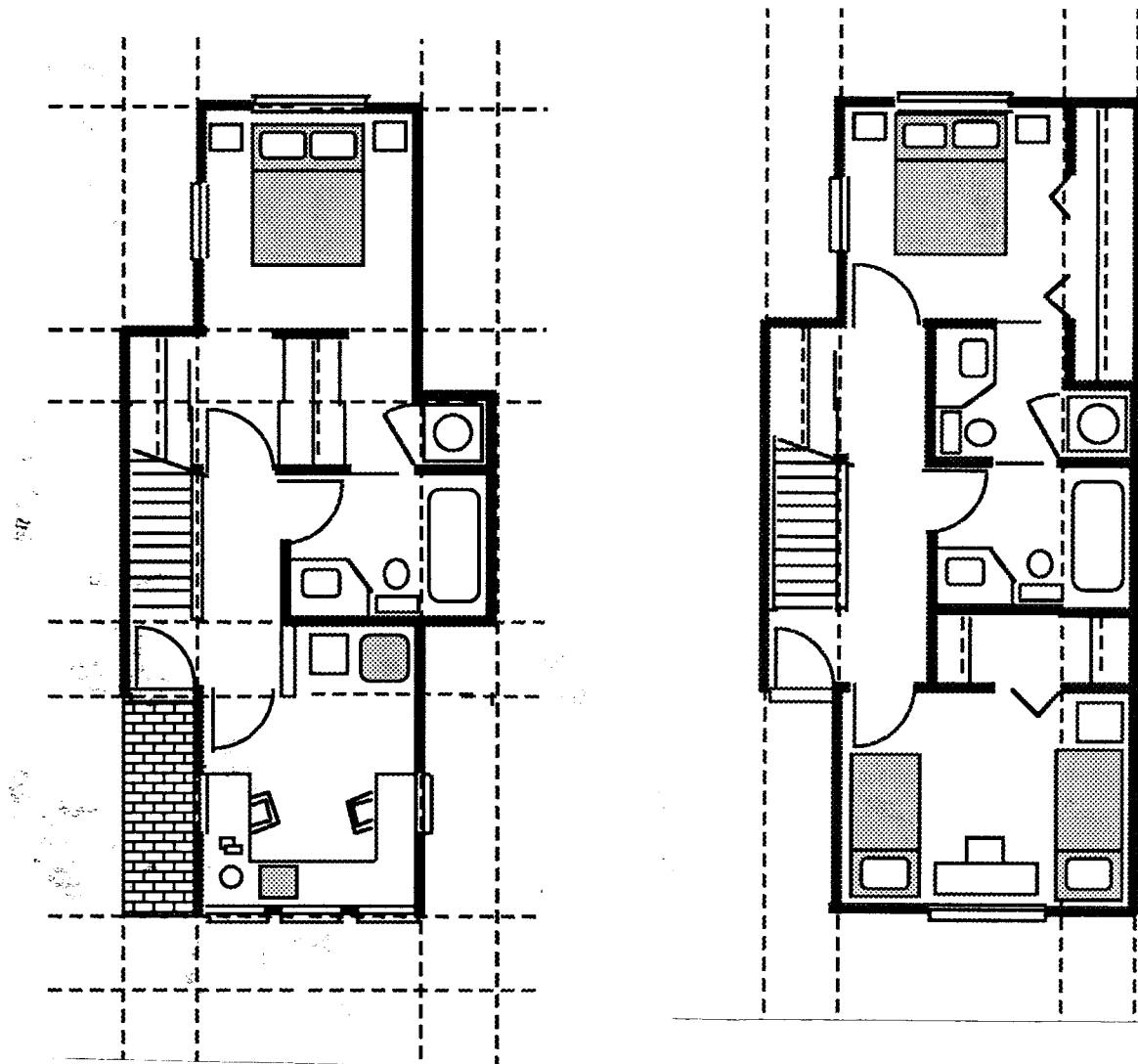

The kitchen and dining areas are located on the second floor of the unit. The original roof terrace to the north is "filled in" with a rental room adjacent to the kitchen. A new roof terrace is then added on to the south side of the unit. The third floor originally encloses a small living room. This room is expanded, and another roof terrace built to the north when the extra room is rented out and additional space is required.

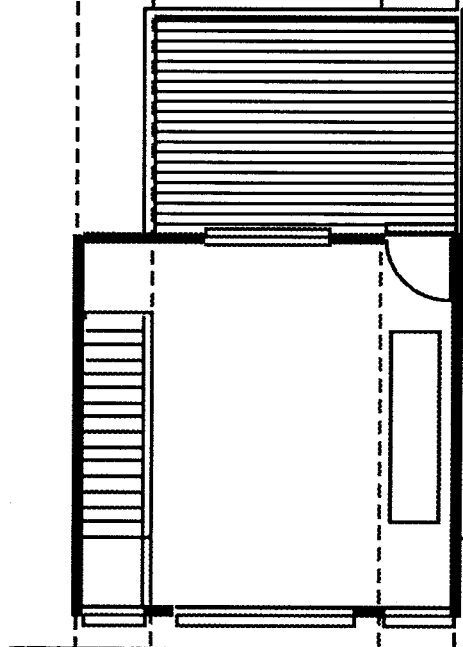
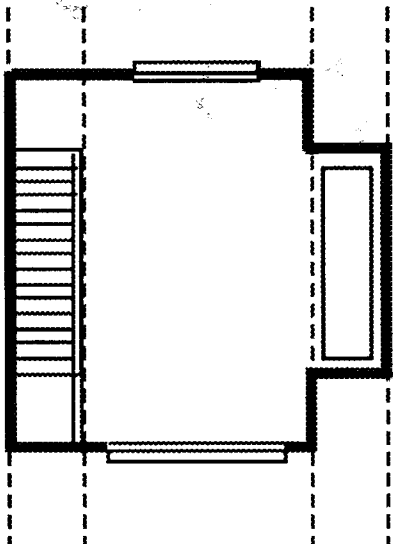
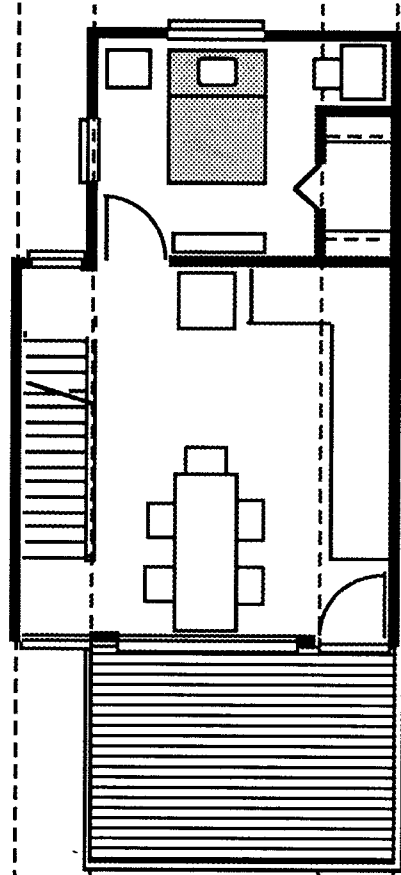
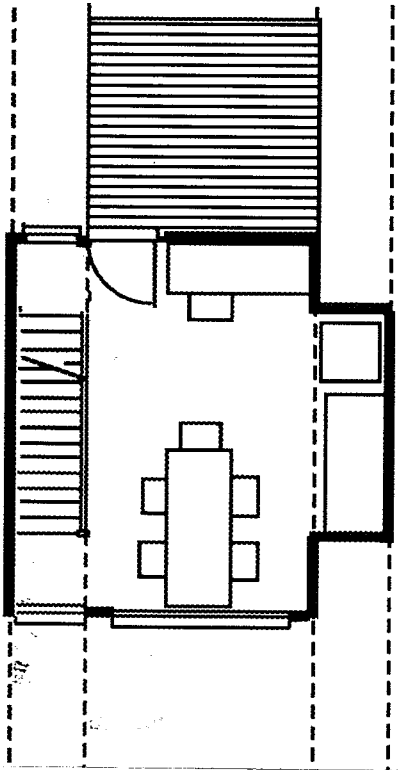

Another version of a three story unit. In this case the entry and the home office are located on the north and common areas are to the south. The home office has already been converted to a rental unit. It is located on the ground level with the other "public activity spaces" - kitchen and dining. The second floor (not shown) is one large open living area with media center, exercise room, and sitting alcoves. It is where the live-in adult tenant and the family members live together. The master bedroom and children's room are located on the third floor, providing zoning for private family space.

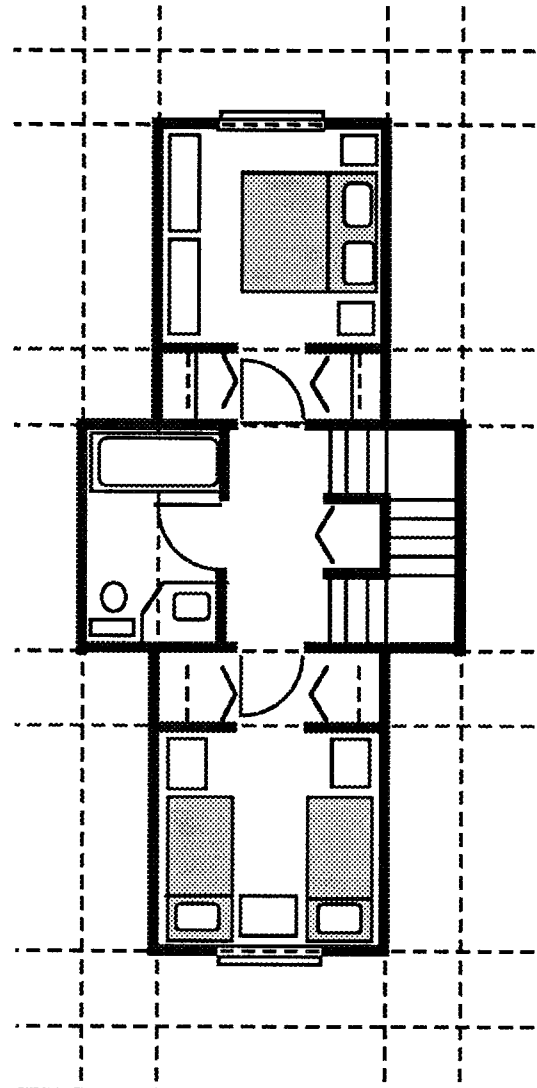
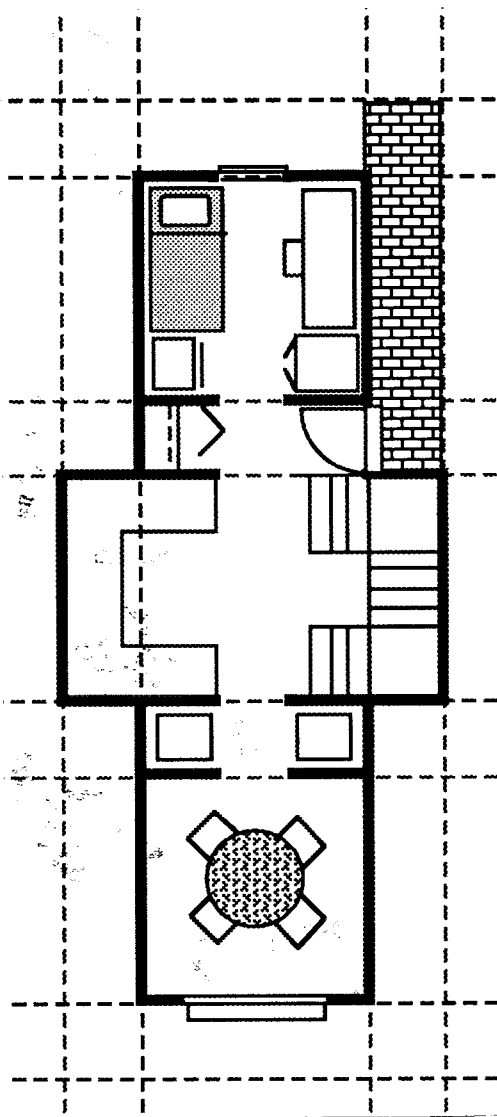

Row house concept, three story units, 5m by 13m, with home office, interior courtyard, and active space/private space zoning. (First prize, New American Home Competition, Leavitt and West, architects.)

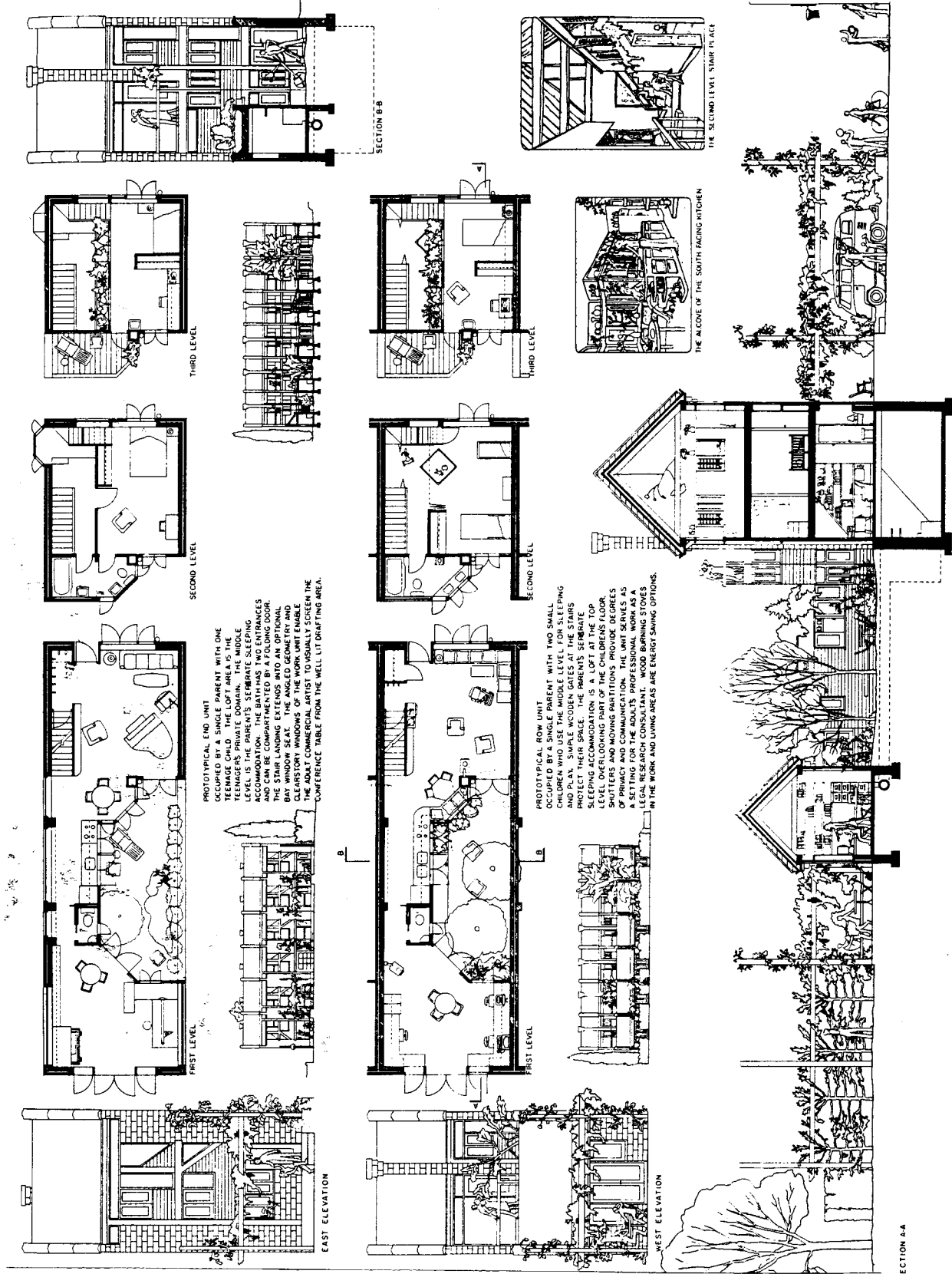

PROTOTYPICAL END UNIT OCCUPIED BY A SINGLE PARENT WITH ONE TEENAGE CHILD. THE LOFT AREA IS THE PARENTS' PRIVATE DOMAIN. THE MIDDLE LEVEL IS THE PARENTS' SLEEPING AND PLAY AREA. THE CHILDREN'S SLEEPING AND PLAY AREA IS COMPARTMENTED BY A LOFT AND THE STAIR LANDING EXTENDS INTO AN OPTIONAL BAY WINDOW SEAT. THE ANGLED GEOMETRY AND CLEARSTORY WINDOWS OF THE WORK UNIT ENABLE THE ADULT COMMERCIAL ARTIST TO VISUALLY SCREEN THE CONFERENCE TABLE FROM THE WELL-LIT DRAFTING AREA.

PROTOTYPICAL ROW UNIT OCCUPIED BY A SINGLE PARENT WITH TWO SMALL CHILDREN WHO USE THE MIDDLE LEVEL FOR SLEEPING AND PLAY. SIMPLE WOODEN GATES AT THE STAIRS PROTECT THEIR SPACE. THE PARENTS' SLEEPING ACCOMMODATION IS A LOFT AT THE TOP LEVEL OVERLOOKING PART OF THE CHILDREN'S FLOOR. THE CHILDREN'S SLEEPING AND PLAY AREAS OF PRIVACY AND COMMUNICATION. THE BAY SERVES AS A SETTING FOR THE ADULT'S PROFESSIONAL WORK AS A LEGAL RESEARCH CONSULTANT. WOOD BURNING STOVES IN THE WORK AND LIVING AREAS ARE ENERGY-SAVING OPTIONS.

THE SECOND LEVEL SLEEPING PLACE

THE ALCOVE OF THE SOUTH FACING WINDOW

SECTION A-A

Staggered row house concept, two or three story units, 5m by 13m, north and south courtyards, entry on either side, common areas to the north. (Grove Court Townhouses, Houston, Texas, Taft Architects.)

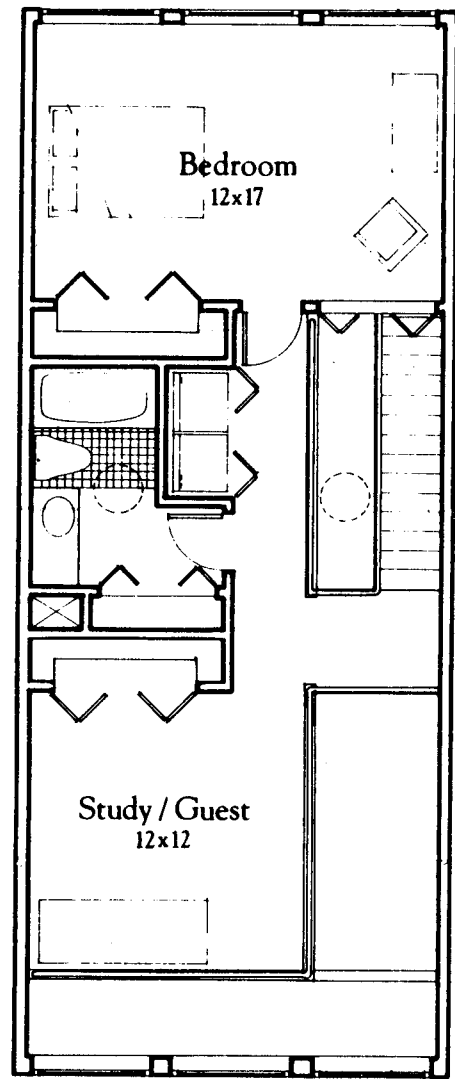
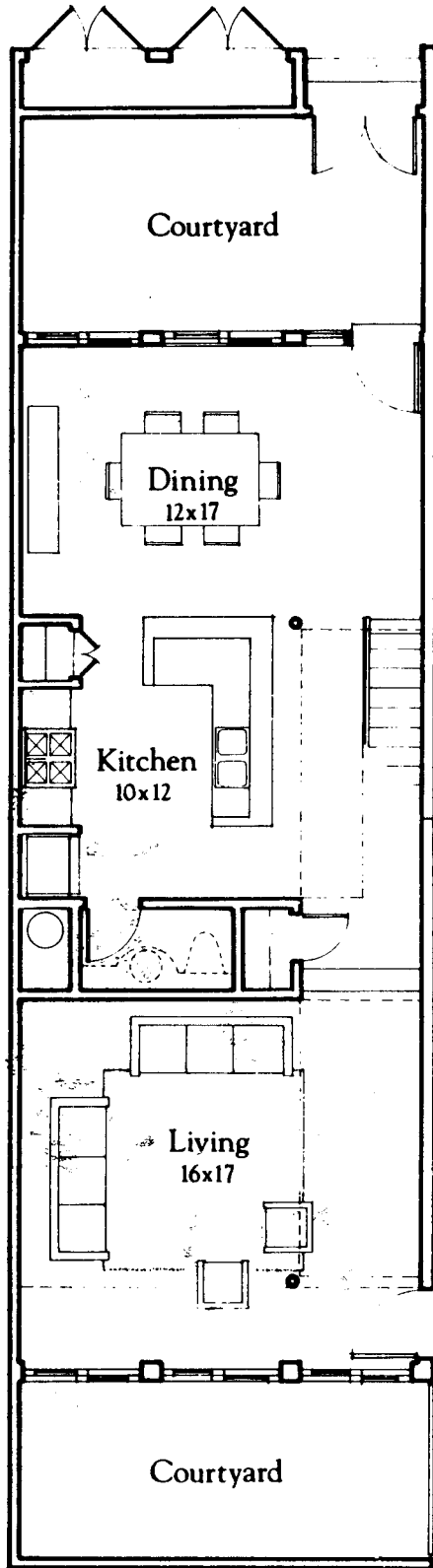

This two story unit features lots of outdoor living space and room for expansion while preserving that space. The ground floor plan includes an office and entry to the north and dining room and entry to the south facing common areas. The master bedroom, located on the second floor, has access to 2 private terraces, one sunny, the other shaded. Kitchen and bathroom plumbing are stacked in a mechanical core. The second floor of this unit changes as the families spatial needs grow. (See next page.)

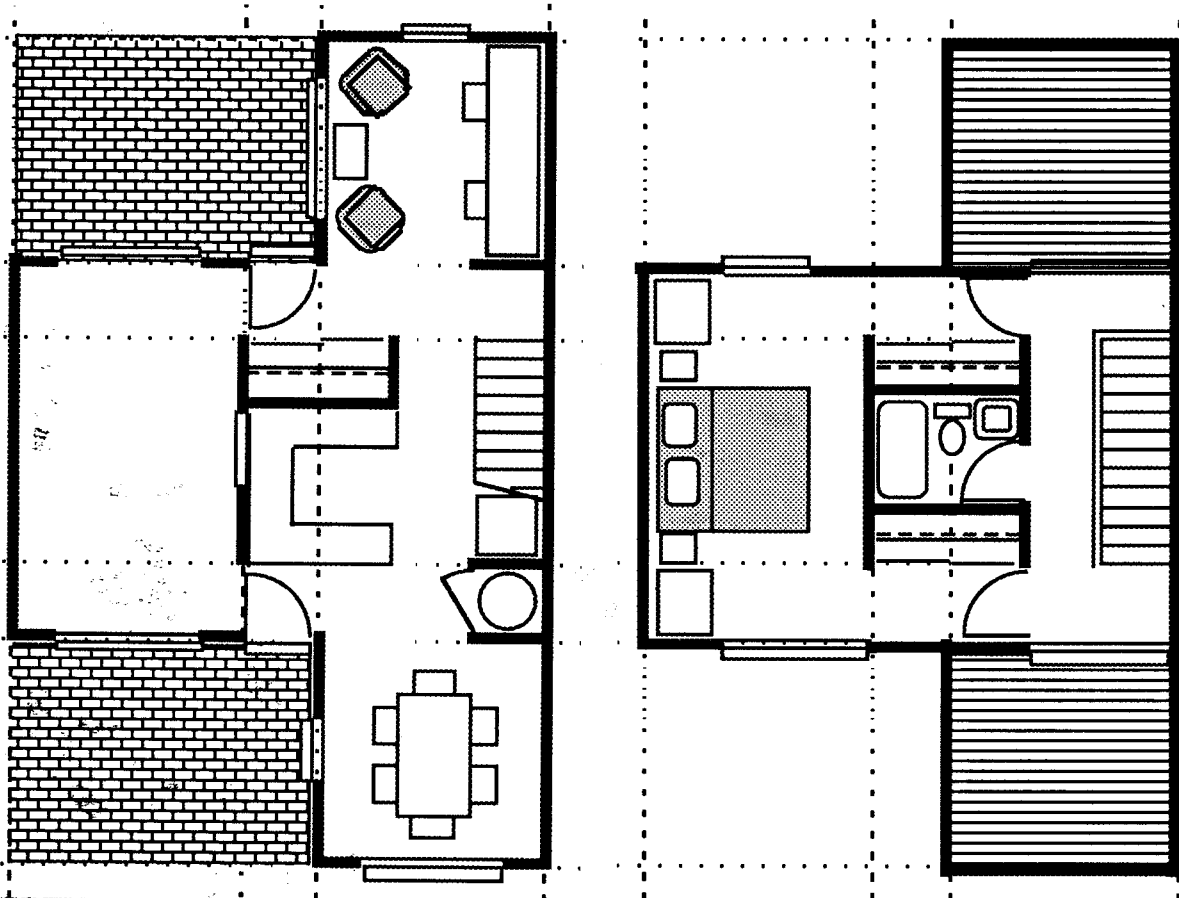

In order to house 2 children, first the north roof terrace is enclosed as a double bedroom (left). As the children grow, the south roof terrace can also be converted into a bedroom. If a rental room is required, the home office on ground level can be remodelled allowing family private space to remain separate on the second floor.

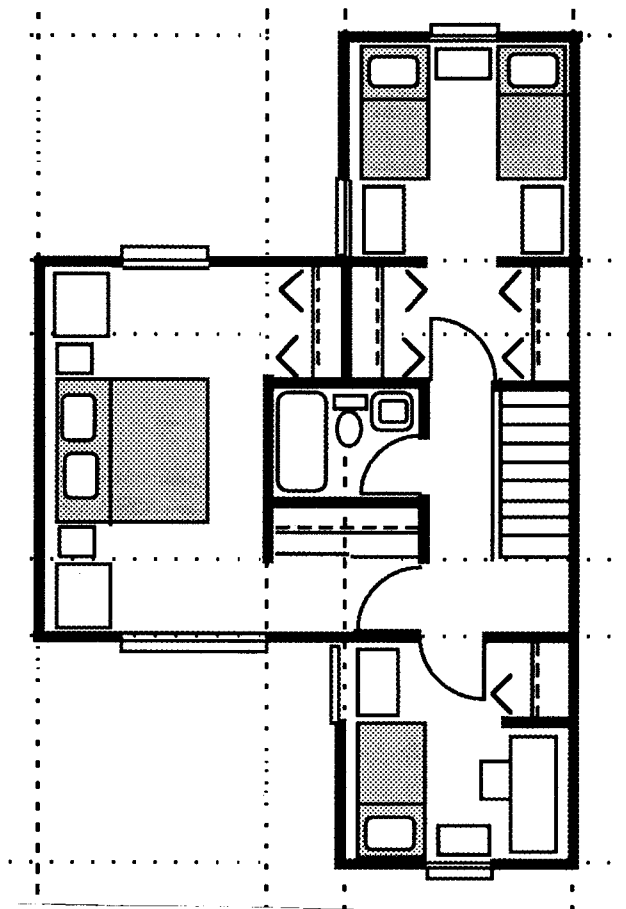
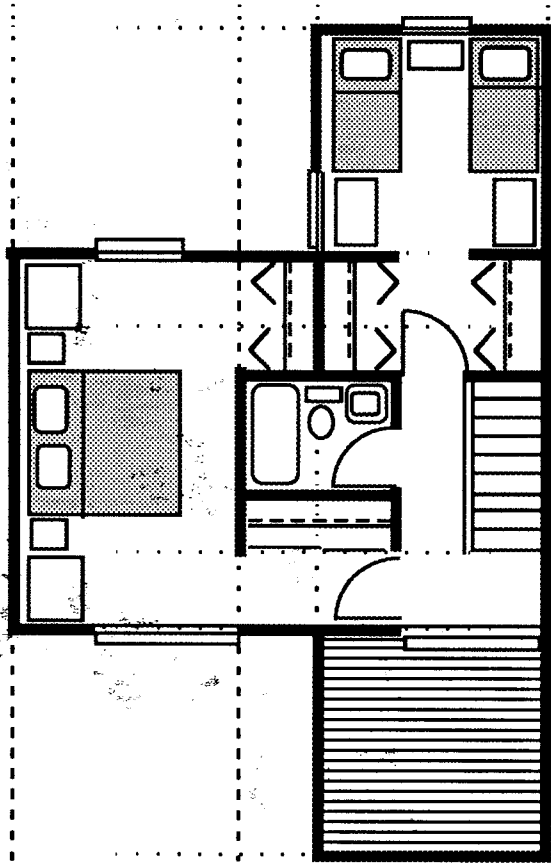

This two story unit preserves outdoor living space, while at the same time including a rental room on the ground floor and bedrooms for 2 adults and 2 children on the second floor. The family has their own private second story, south facing roof terrace. Note that the ground floor living room has been enlarged to accommodate an extra live-in adult, and the west bedroom over it can now provide enough room for two children.

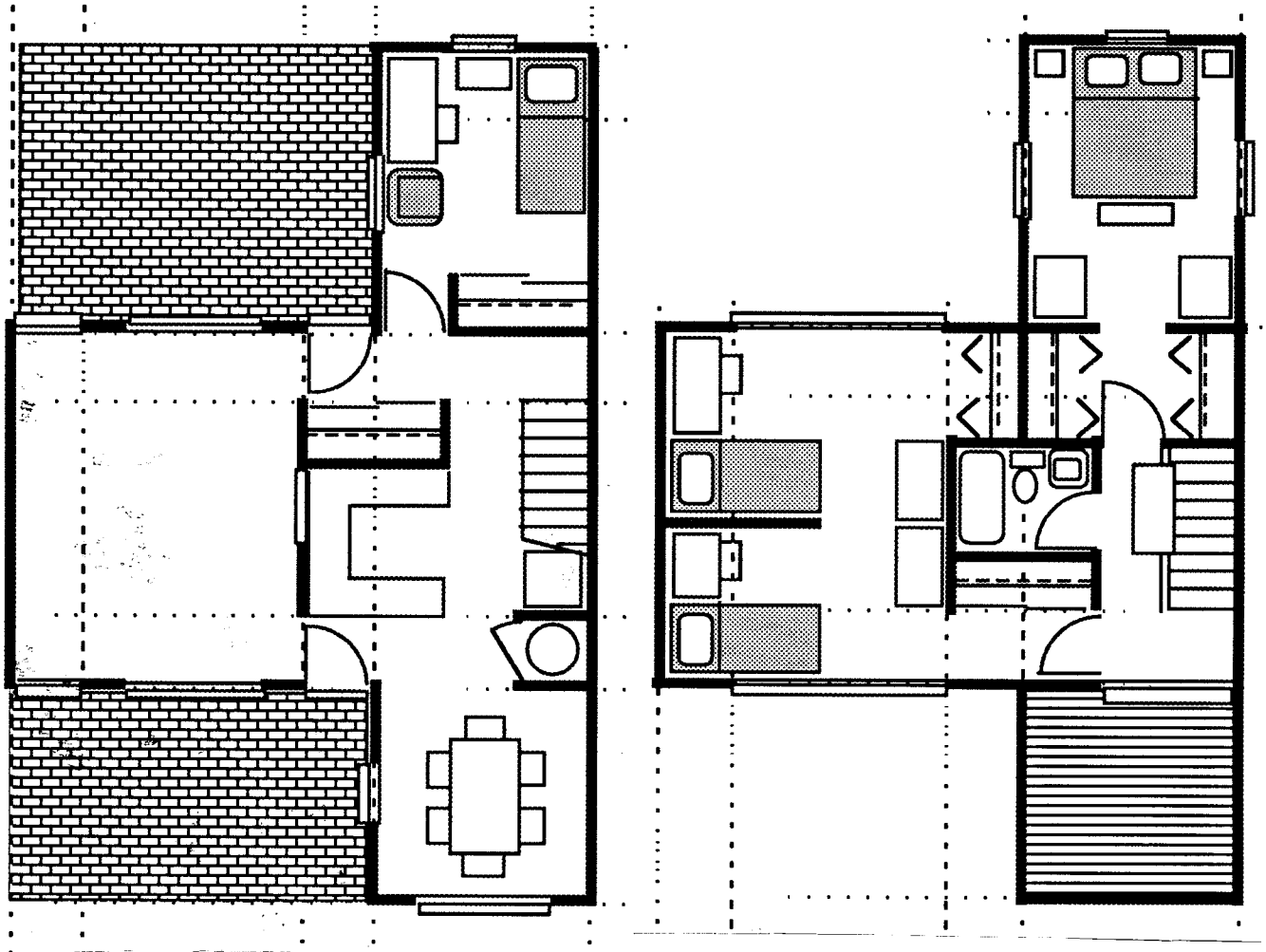

Two story unit, 6m by 9m, post and beam structure, south entry, common areas to north, courtyard to east. (Compact House Design Competition, award, Mark Nielsen, designer.)

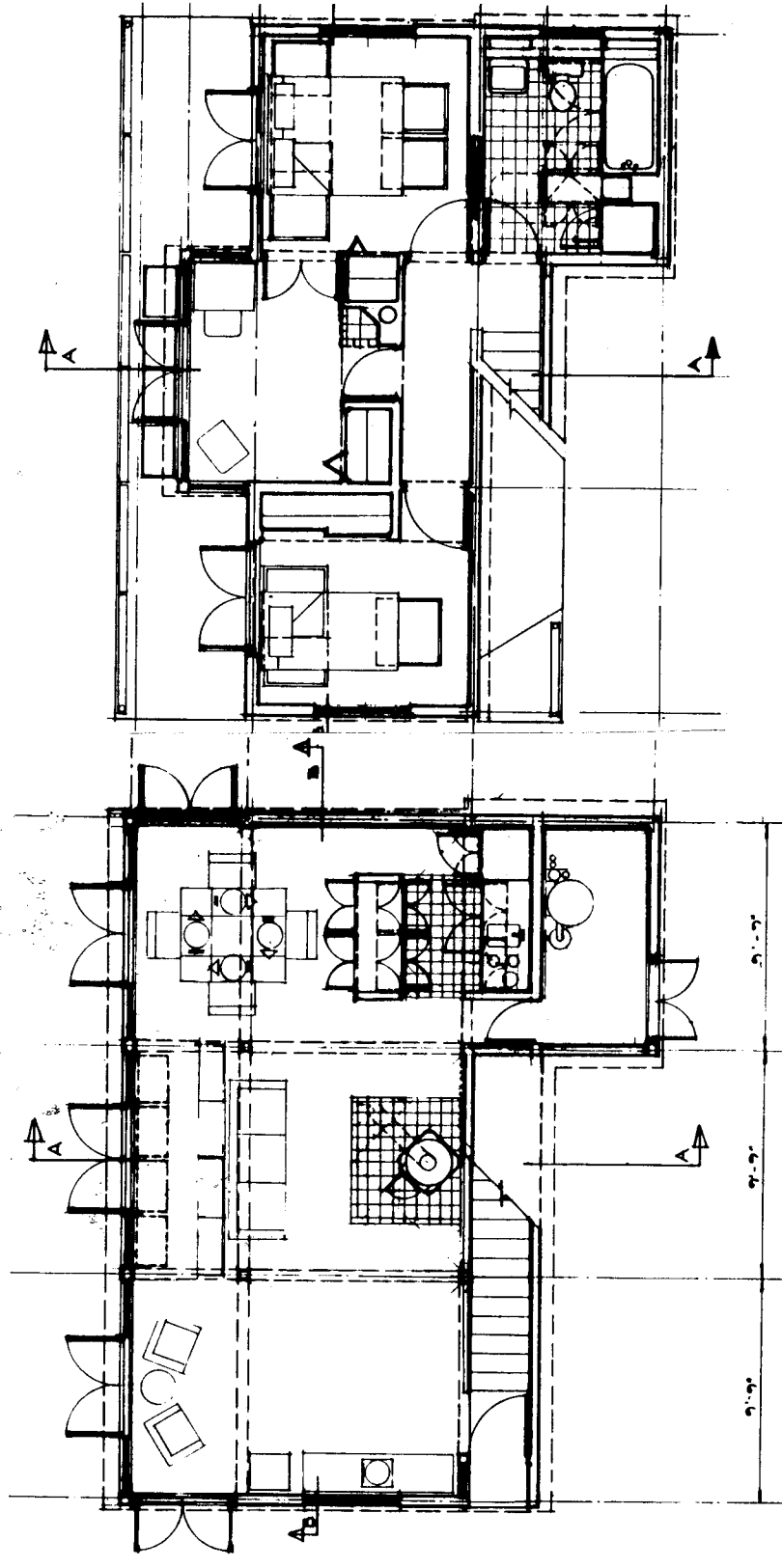

Two story unit, 8m by 8m, living, dining, master bedroom facing south to common areas, north entry. (Compact House Design Competition, award, Thomas Leytham, architect.)

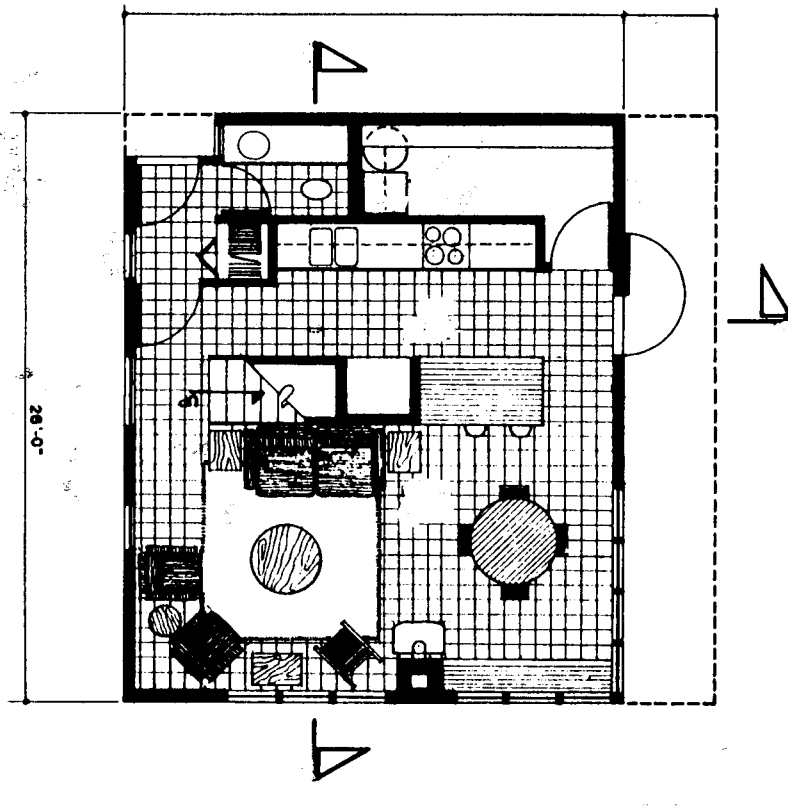
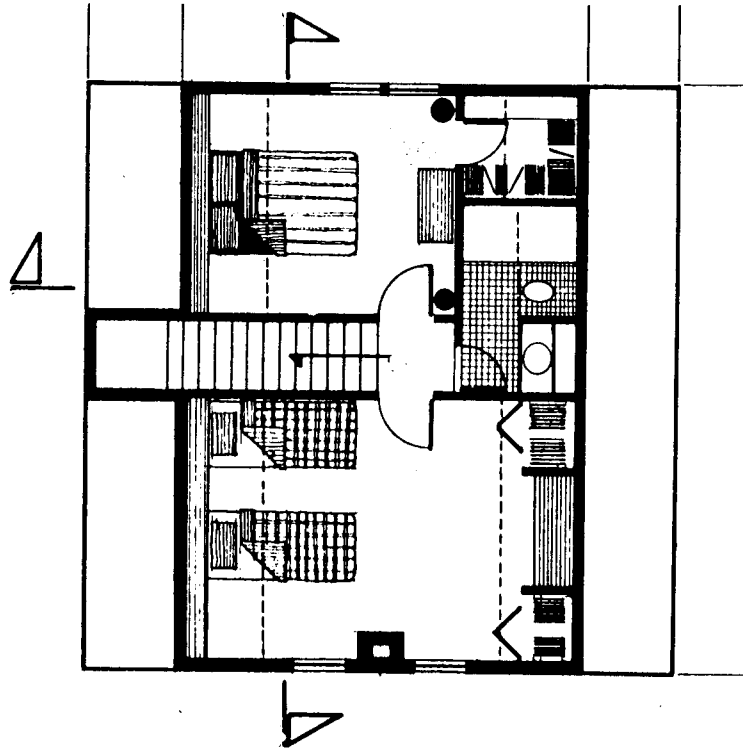

Two story unit, 9m by 13m, living, dining, kitchen oriented south to common areas, entry through east side courtyard. (Compact House Design Competition, award, Arunas Rumsa, designer.)

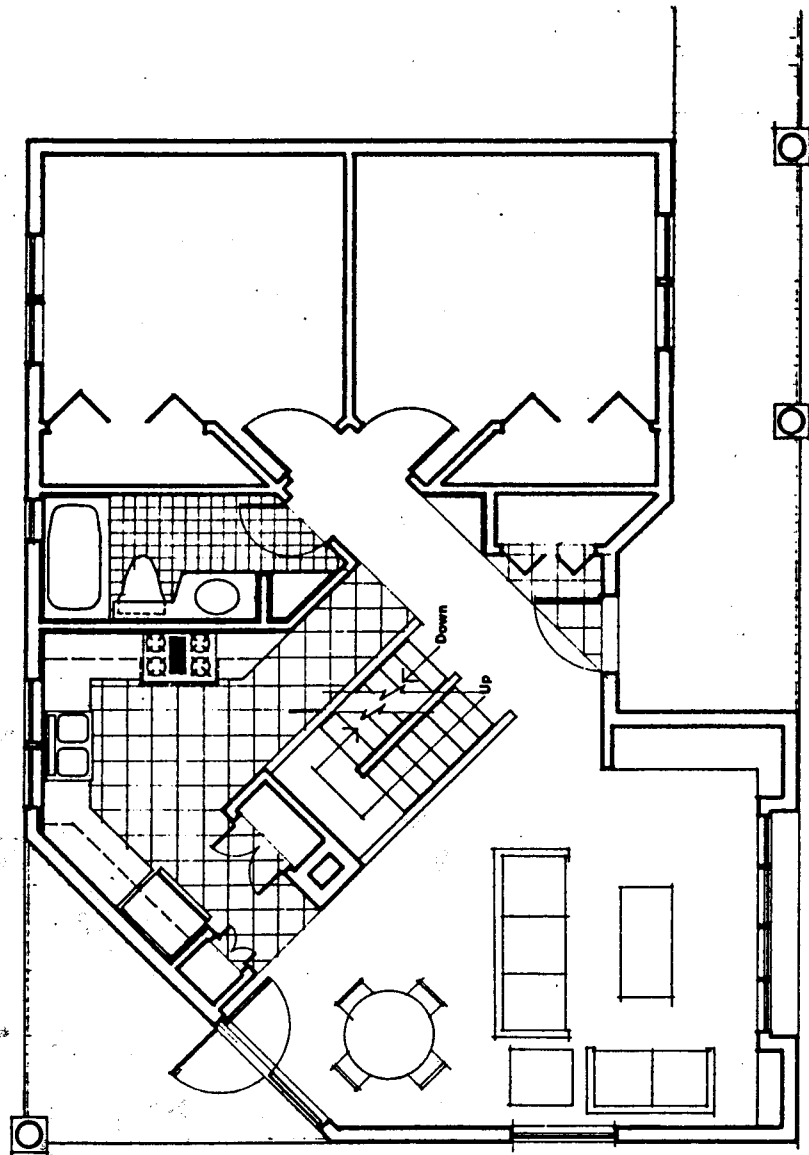

This one story plan is laid out to provide daylighting and outdoor living spaces for every room. The original plan allows both north and south entries. The home office is on the north with the dining room facing the common areas to the south. The kitchen and bathroom are attached in an mechanical core. The office is converted into a bedroom to provide space for two children (next page).

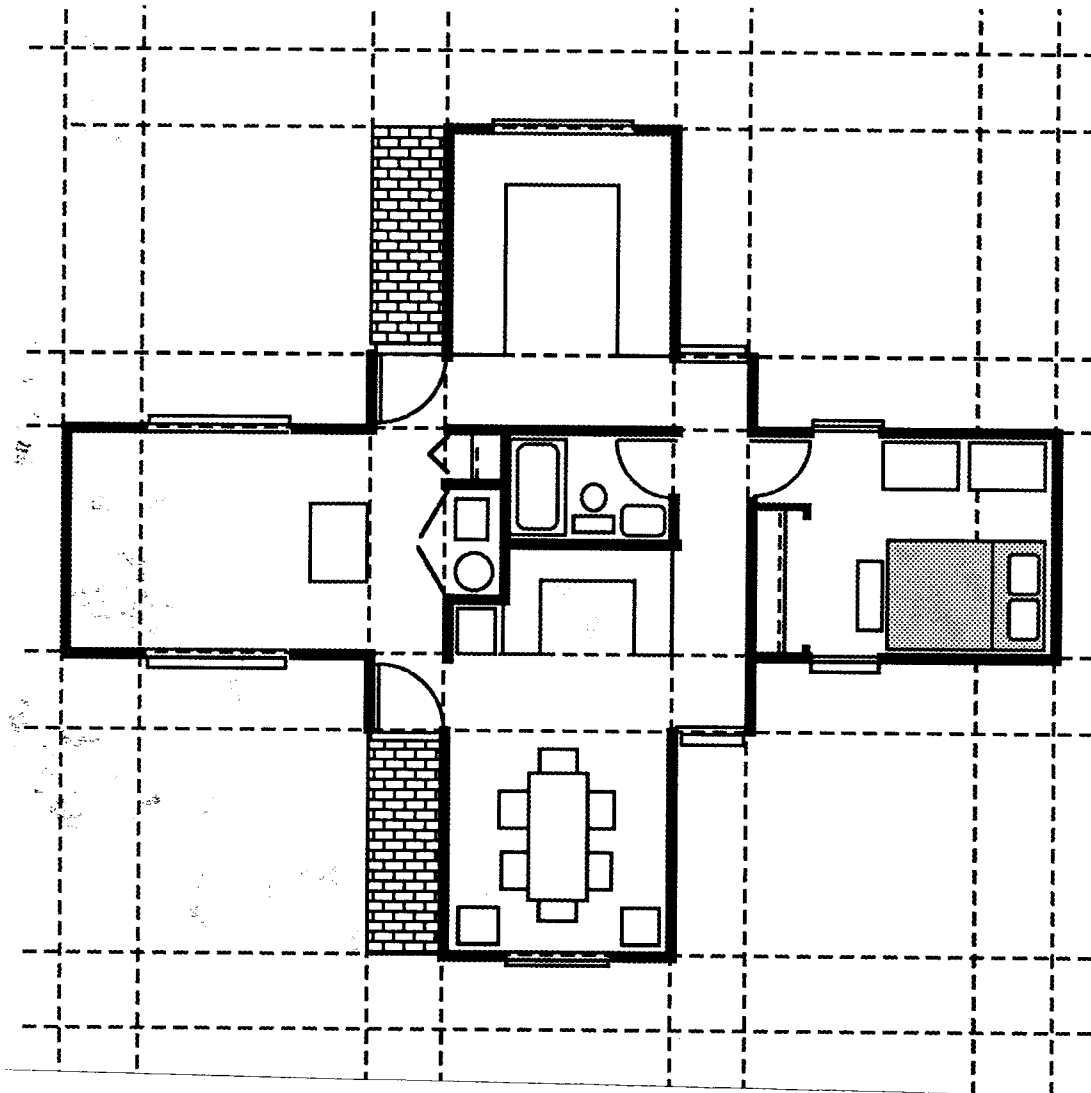

The home office has been enlarged 1 meter to the north to accommodate the needs of two children. Outdoor living spaces have been preserved. To accommodate a live-in adult tenant, the northeast courtyard between the children's and parent's bedroom would have to be enclosed. Bedrooms could then be re-arranged so that the tenant's room is across from the kitchen, and the children's room and parent's room are adjacent to one another.

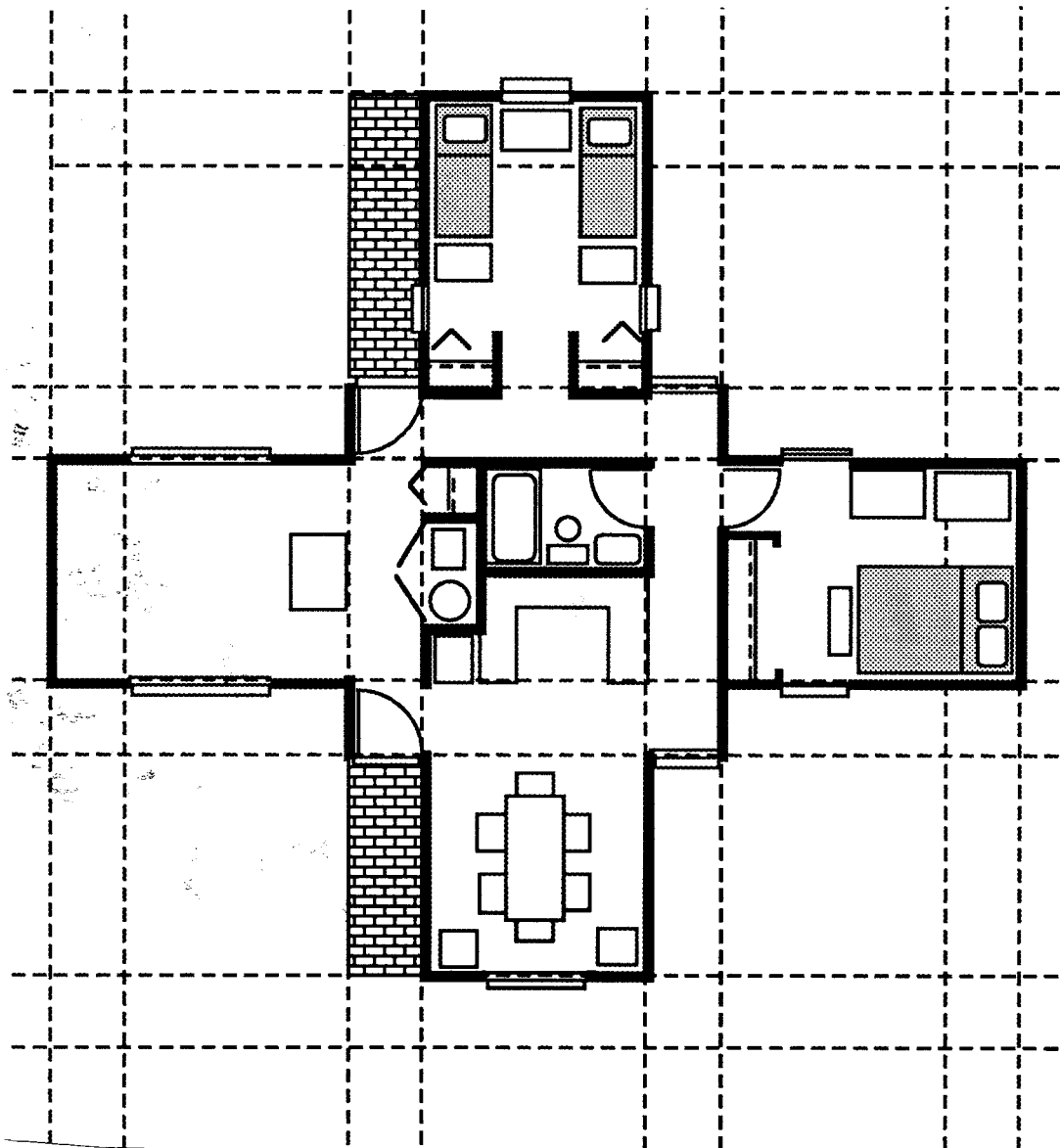

This fully developed one story plan provides rooms for 2 parents, 2 children, and 1 adult live-in tenant while preserving three different areas of private outdoor living. The children and parents share a courtyard to the east while the tenant can use the northwest courtyard. The living room faces south onto the third courtyard which is shared with the dining room. Entry is on the south connecting the house to the common areas.

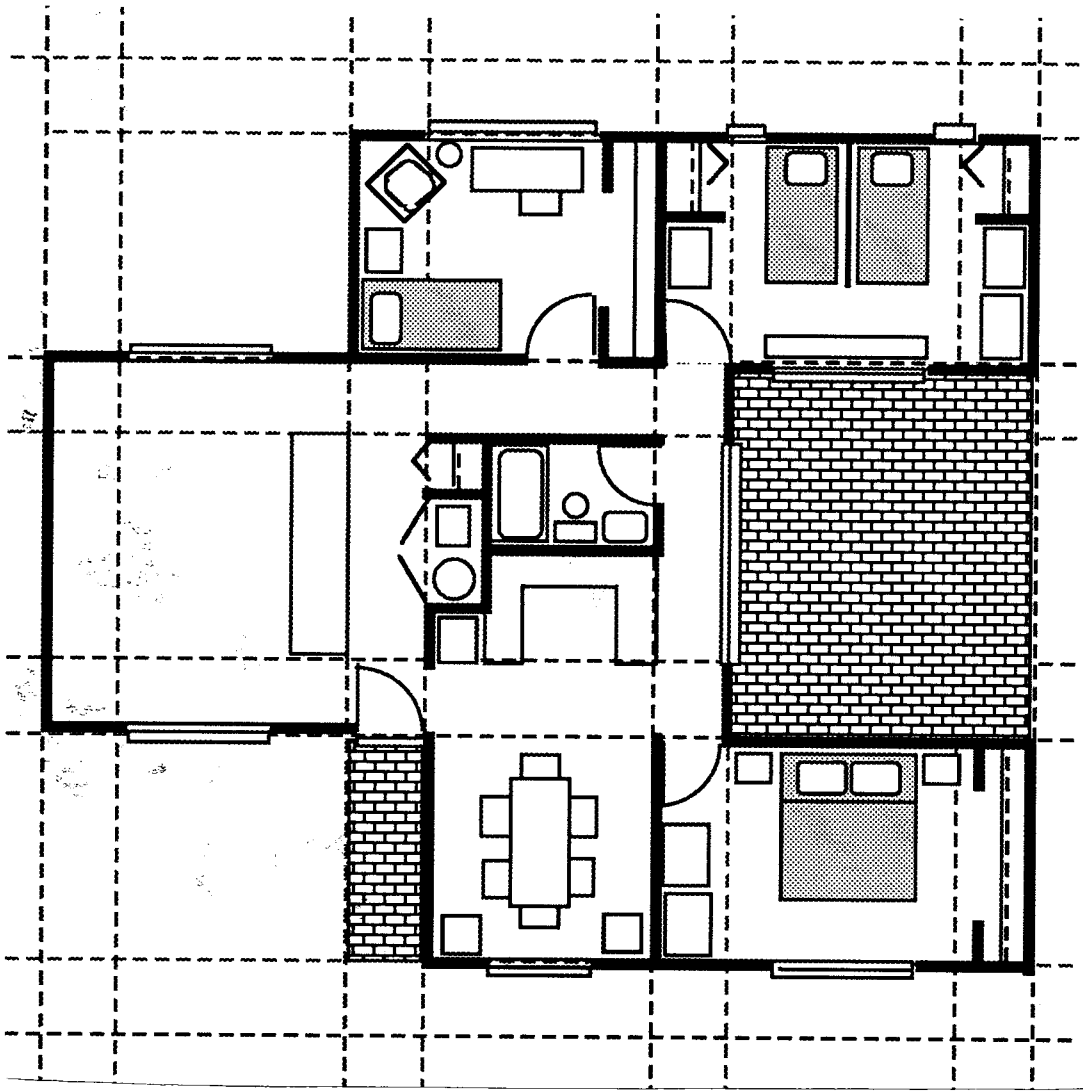

Plans on the next two pages are for a one story unit with a north entry and living spaces facing common areas to the south. The original plan accomodates 2 parents and 1 or 2 children. The formal dining room can be converted into another bedroom for rental or to provide more space for a growing child. The dining area is then re-located to the southwest corner of the house for a prime view to the common area and connection to the south facing courtyard.

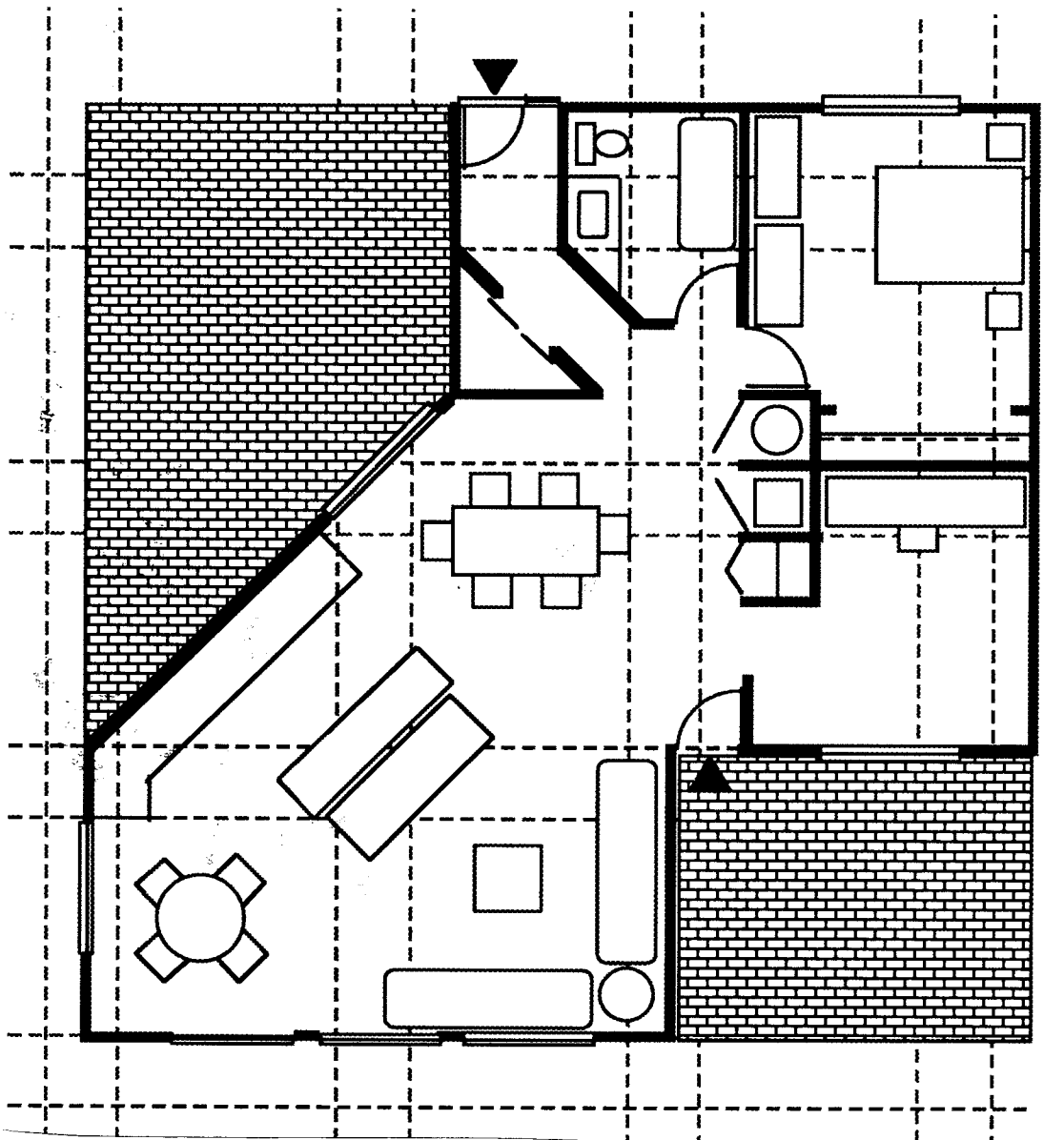

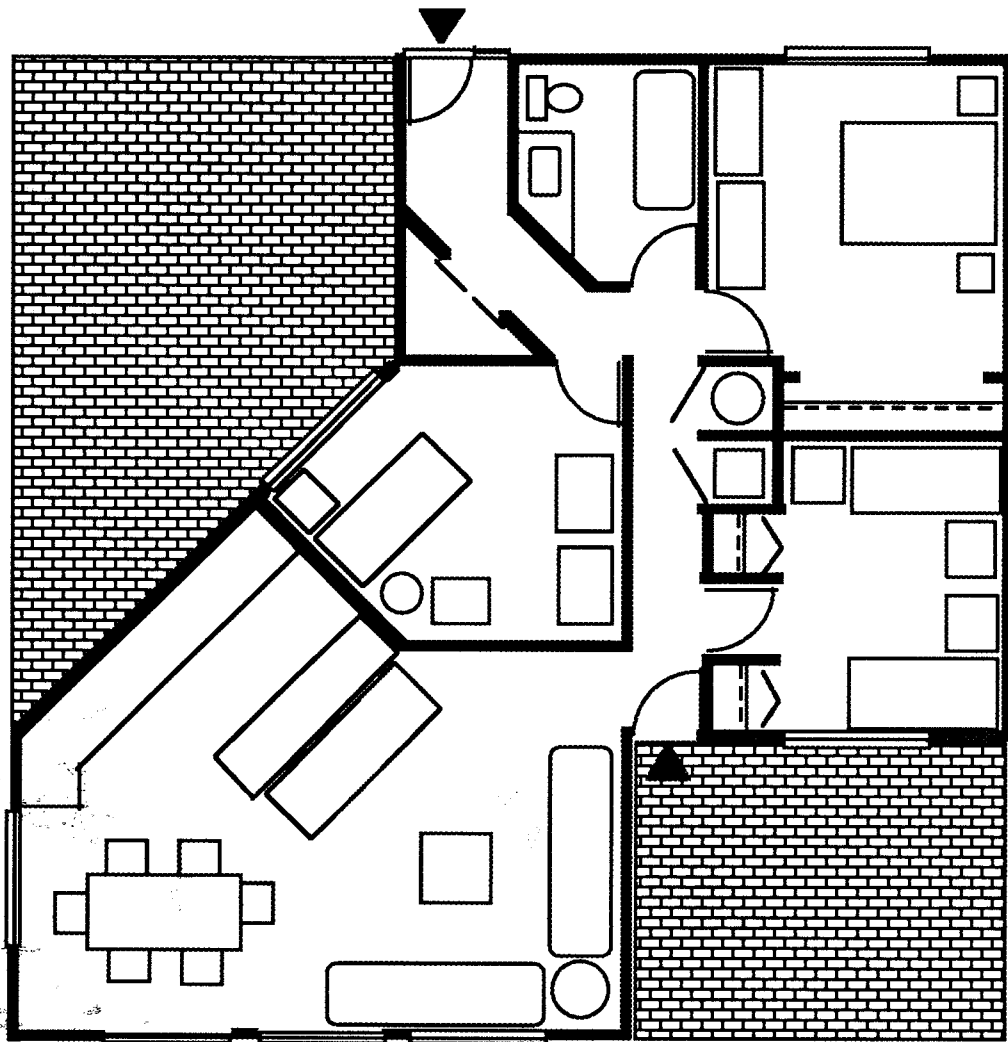

A compact one story unit, 11m by 8m, north entry, living and dining oriented south, expansion area to the north. (Gorton and Bounds, designers.)

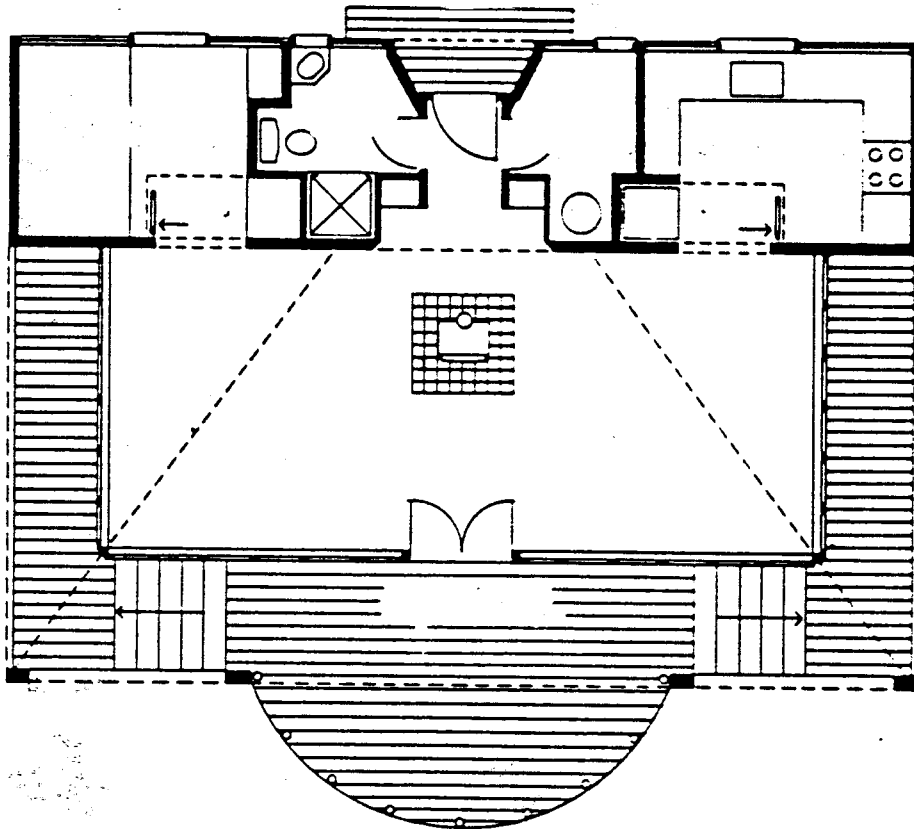

One story unit, 13m by, 8m, with a 5m wide covered central breezeway running north-south (Texas "dog trot house"), expansion to north or between living and sleeping quarters. (Compact House Design Competition, award, Michael Underhill, architect.)

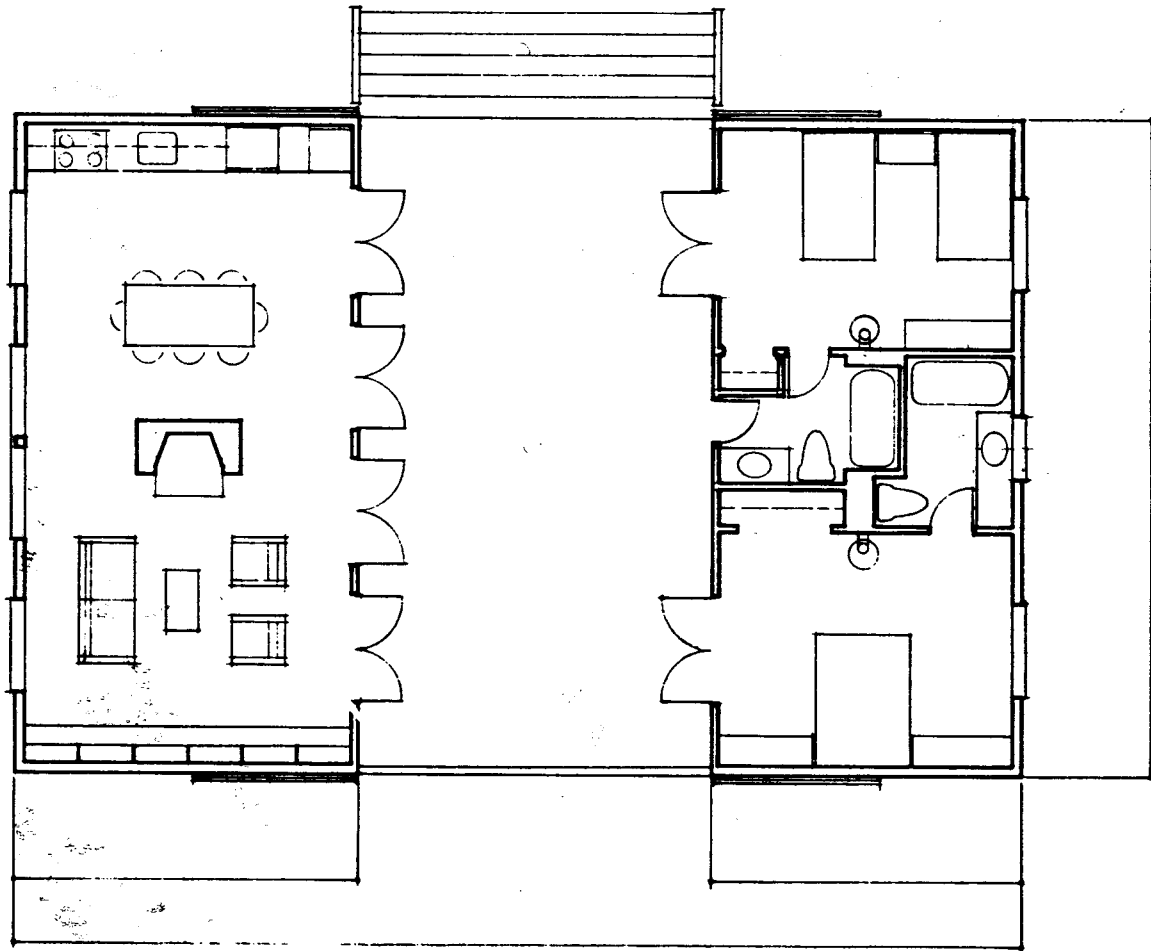

One story unit, 11m by 8m, rooms oriented to the south with outdoor living spaces. east side entry. (Compact House Design Competition, award, Robert Giddings, architect.)

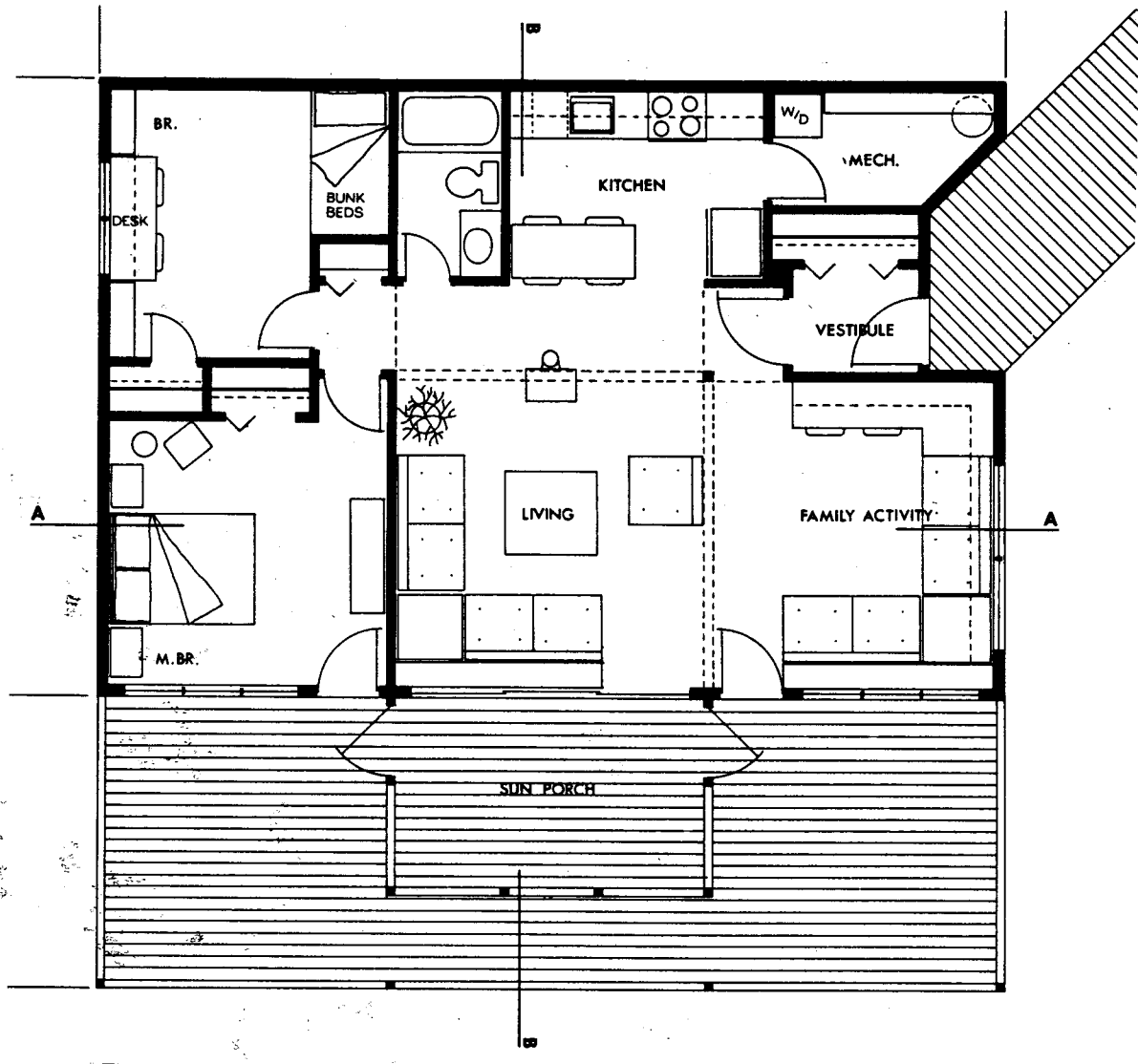

TYPICAL SECTION

VARIABLE INSULATING ROOF
 TOP RADIANT LAYER WITH PIPING
 PLASTIC LINER
 CLOSED CELL INSULATION
 RADIANT FLOOR LAYER WHEN CONVERTED
 TO FLOOR EXPANSION WITH PIPING
 EMBEDDED
 ICEILING SIDE RADIANT BARRIER

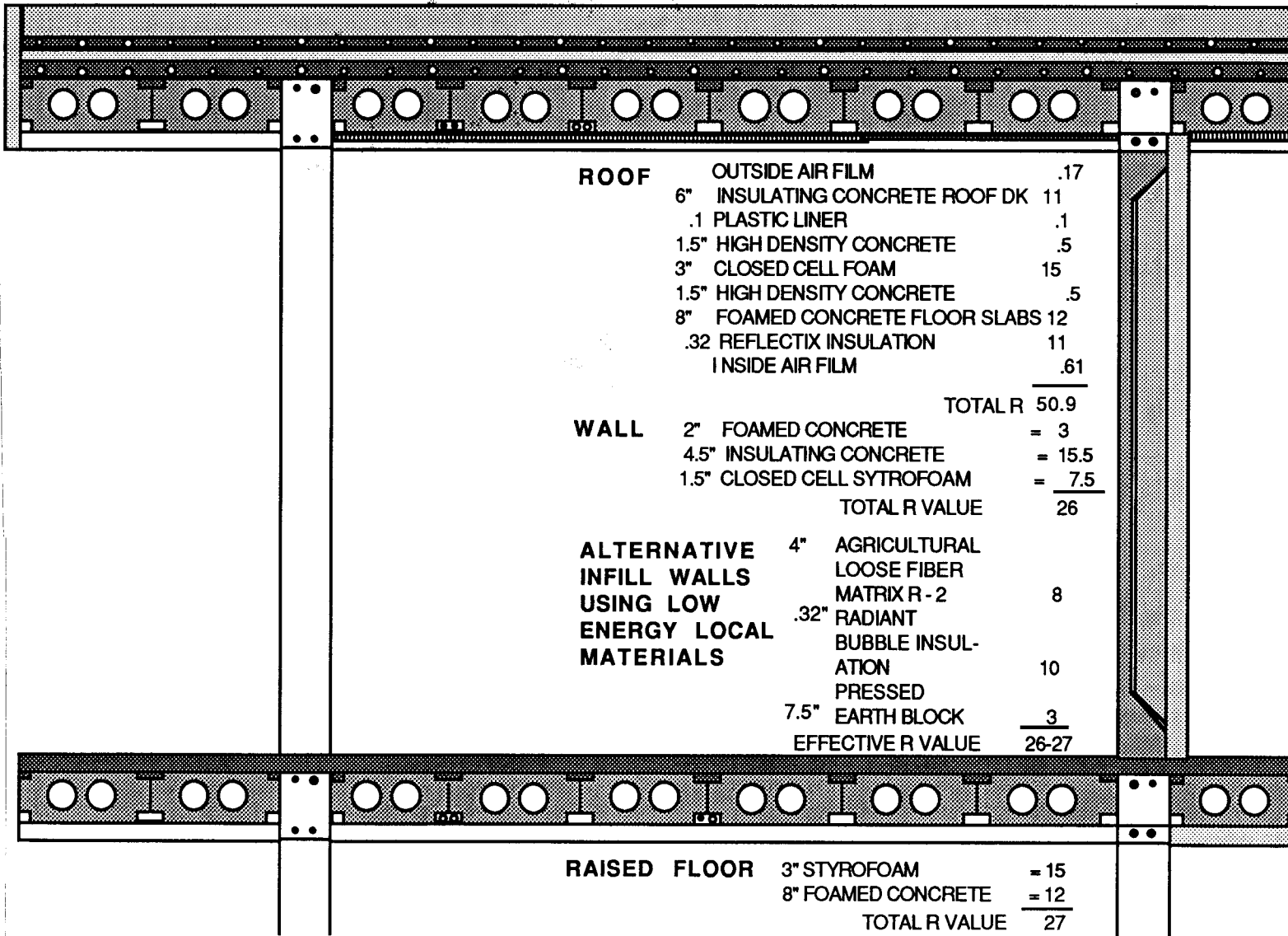

ROOF	OUTSIDE AIR FILM	.17
	6" INSULATING CONCRETE ROOF DK	11
	.1 PLASTIC LINER	.1
	1.5" HIGH DENSITY CONCRETE	.5
	3" CLOSED CELL FOAM	15
	1.5" HIGH DENSITY CONCRETE	.5
	8" FOAMED CONCRETE FLOOR SLABS	12
	.32 REFLECTIX INSULATION	11
	INSIDE AIR FILM	.61

TOTAL R 50.9

WALL	2" FOAMED CONCRETE	= 3
	4.5" INSULATING CONCRETE	= 15.5
	1.5" CLOSED CELL SYTROFOAM	= 7.5
	TOTAL R VALUE	26

ALTERNATIVE INFILL WALLS USING LOW ENERGY LOCAL MATERIALS	4" AGRICULTURAL LOOSE FIBER MATRIX R-2	8
	.32" RADIANT BUBBLE INSUL- ATION	10
	PRESSED	
	7.5" EARTH BLOCK	3
	EFFECTIVE R VALUE	26-27

RAISED FLOOR	3" STYROFOAM	= 15
	8" FOAMED CONCRETE	= 12
	TOTAL R VALUE	27

STRUCTURAL SYSTEM - FRAME AND SLAB

1

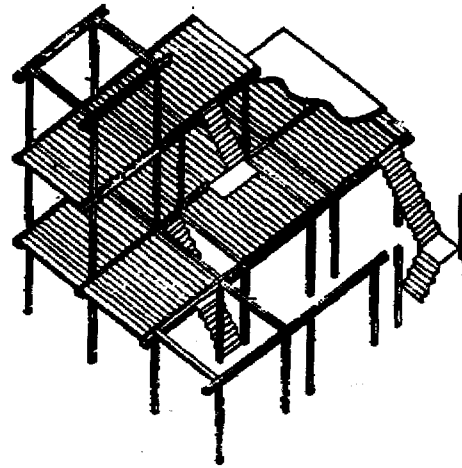
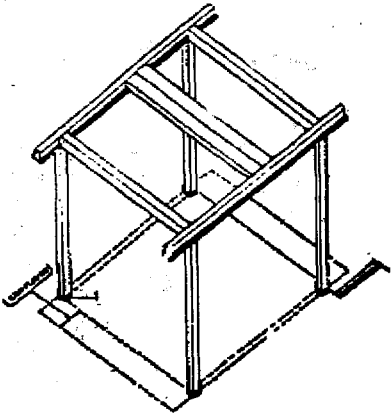

The system is designed so that all component parts can be produced by local manufacturers.

The components are all light-weight so that they can be assembled into a house without the need for cranes or other mechanical lifting machinery.

The structural system has been widely tested and proven successful. It is earthquake resistant.

No special training or specific skills are required to manufacture the parts or to build the homes. Appropriate instruction techniques and manuals are available.

The occupant can easily learn to build and improve his own home. The Mitchell Framing System provides the opportunity to improve the wall materials and make the house larger whenever the family has the materials.

The Mitchell Framing System was first presented to an international audience at the United Nations in August/September 1967 in connection with the United Nations Seminar on Prefabrication of Houses for Latin America. The system has been presented to government authorities in many parts of the world and prototypes have been erected in Argentina, Venezuela and Vietnam.

In America, the Mitchell Framing System has been chosen by the Housing and Urban Development Department in connection with OPERATION BREAKTHROUGH. Housing utilizing this System has been built in Lancaster, Pennsylvania, in Cambridge, Massachusetts in Pittsfield, Massachusetts, in Austin, Texas, and in Augusta, Maine.

A non-bearing, precast, cellular concrete membrane wall has been developed for use in the System. However, mud blocks, metal, wood, or other locally available materials can be used as infill. Technical personnel at Mitchell Systems are available to work with manufacturers to develop and indigenous infill systems.

BUILDING COMPONENTS

BC

A Mitchell System frame is made of reinforced concrete components which are precast at any convenient location. The four basic types of components are called COLUMNS, CANTILEVER BEAMS, TIE BEAMS, and CHANNEL-PLANKS. A frame is erected on the construction site by joining components together with steel bolts. A concrete TOPPING SLAB is poured in place on the top of the frame to give it stability and make it fire- and water-resistant.

All of the concrete used above ground will be a lightweight cellular concrete made with a special foam to trap microscopic air bubbles in the concrete. This additional air makes the concrete more workable during casting, lighter and easier to lift during erection, and more effective as sound and heat insulation when the structure is complete. Directions for preparing and pouring the foamed concrete are found on page 112.

The diagram below shows where the different types of components are used in the erection of one module:

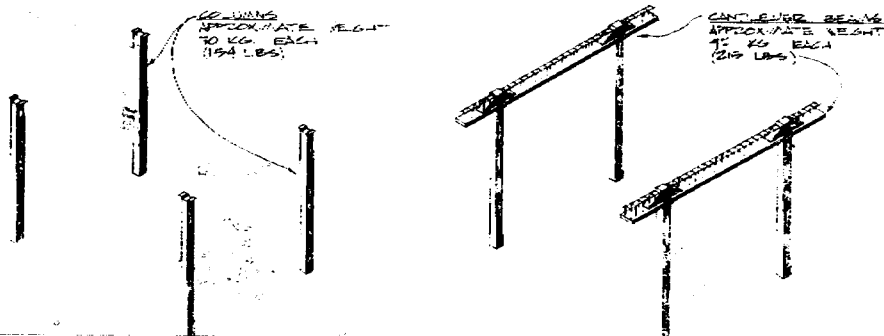

The CANTILEVER BEAMS form two sides of the roof structure by transferring their weight onto the four columns. One cantilever beam fits across the tops of two columns, so two cantilever beams are used with the four columns of a module. This demonstration project will require a total of 14 cantilever beams. The directions for fabricating cantilever beams are found on pages 82 to 94.

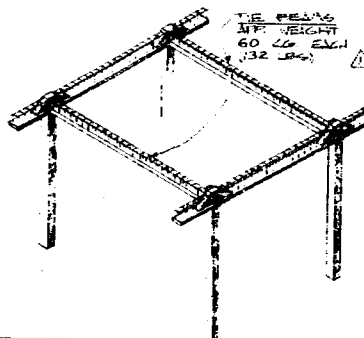

BUILDING COMPONENTS

BC

The components are made of two materials: foamed concrete and steel, the steel being in the form of reinforcing rods, plates, and wire mesh. The steel pieces are assembled to form structures called "cages;" these cages are embedded in the components and provide most of the strength to the structure. The construction kit supplied for this demonstration project contains all the tools necessary for making the cages. It also contains the forms into which the assembled cages are placed and the properly mixed foamed concrete is poured. When the concrete has hardened for about 20 hours, the components, with the steel cages embedded in them, are carefully removed from the forms. This process--assembling the cages and placing them in the forms, mixing the concrete and pouring it into the forms, and removing the hardened components from the forms--is repeated until enough components of each type have been made. The following is a brief introduction to the individual components.

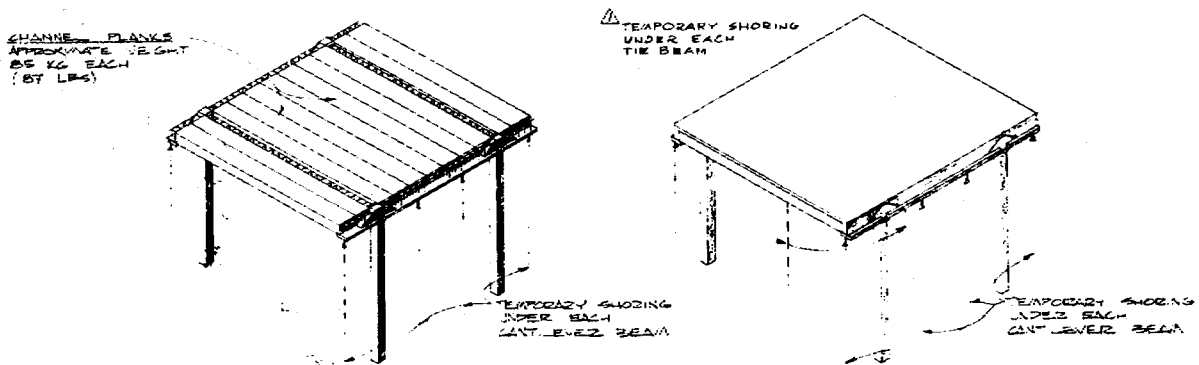

The COLUMNS define the floor and wall areas of a module and provide all the support for the roof and any higher units. Once the foundations have been prepared, four columns are erected to begin the assembly of a module. This demonstration project will require a total of 38 columns. The directions for fabricating columns are found on pages 32 to 63.

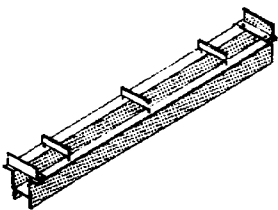

column form

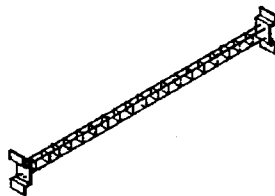

column cage

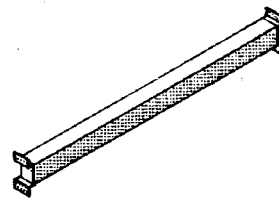

column

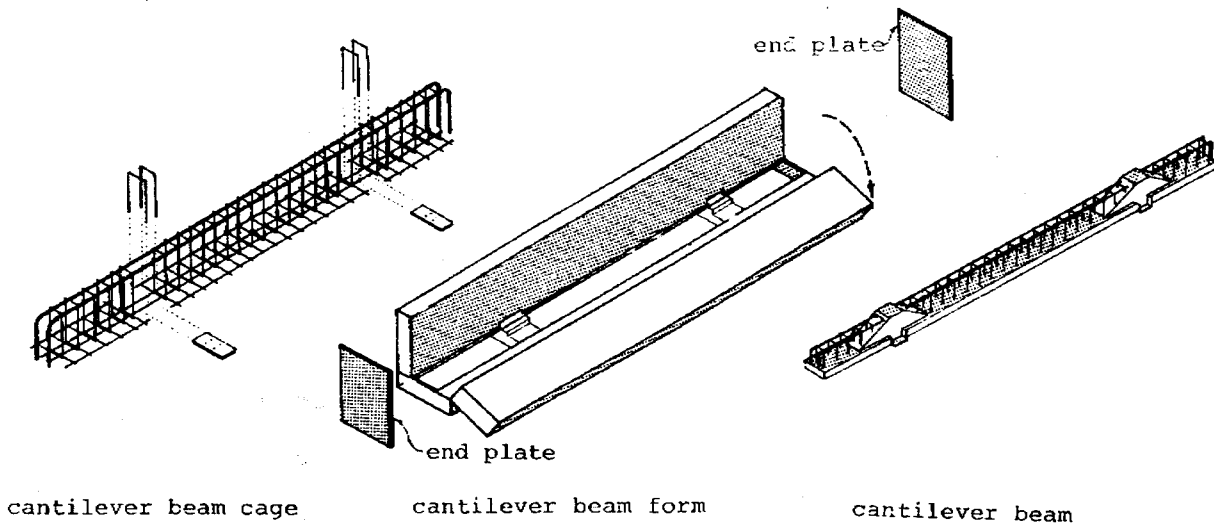

cantilever beam cage

cantilever beam form

cantilever beam

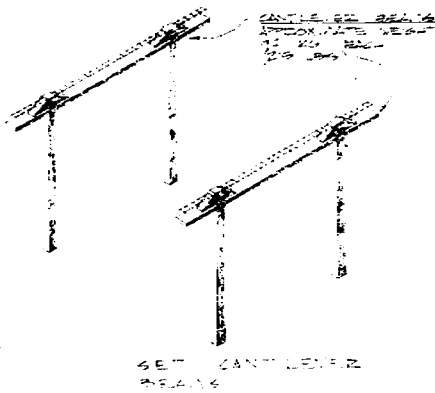

The TIE BEAMS complete the connection of the tops of the columns, making the frame rigid and ensuring that the final roofing components will fit properly onto the cantilever beams. One tie beam joins together two columns. Two tie beams are used with the four columns and two cantilever beams of a module. This demonstration project will require a total of 16 tie beams. The directions for fabricating tie beams are found on pages 64 to 81.

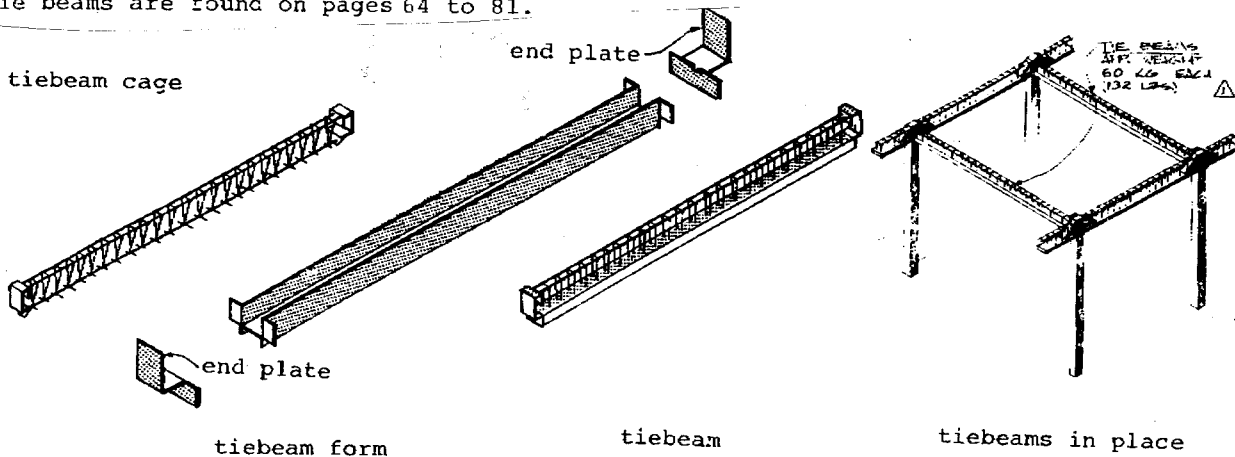

tiebeam cage

tiebeam form

tiebeam

tiebeams in place

BUILDING COMPONENTS

BC

The CHANNEL-PLANKS complete the base for a roof surface of a module; it will also serve as the base for a floor surface for a module built on top of this first one. Eleven channel-planks are fitted between the two cantilever beams used in a module, two planks being placed on the outsides of both tie beams, and seven planks in the middle area between the tie beams. This demonstration project will require a total of 99 channel-planks. The directions for fabricating channel planks are found on pages 18 to 31.

channel plank cage

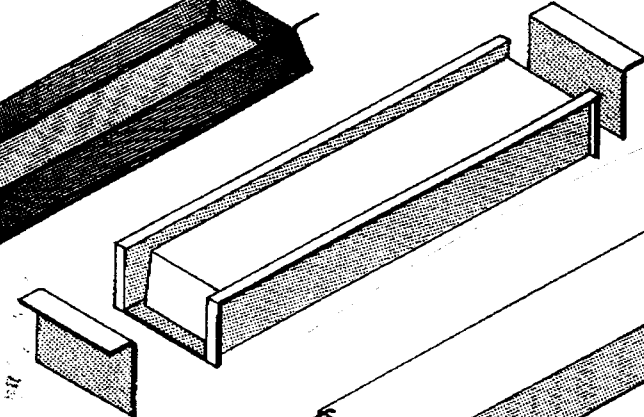
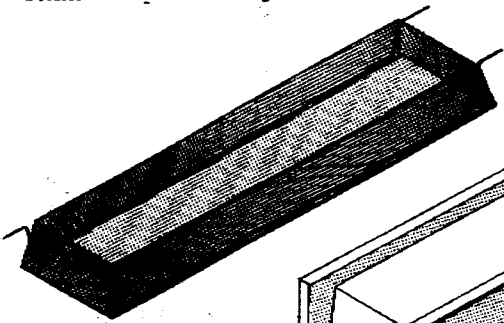

channel plank form

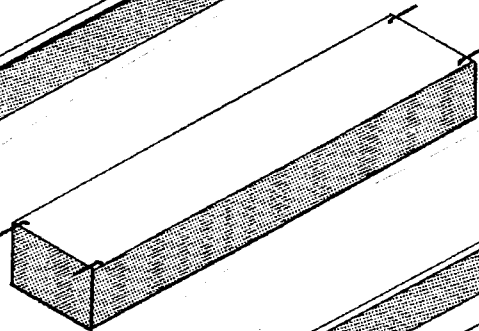

channel plank
(top view)

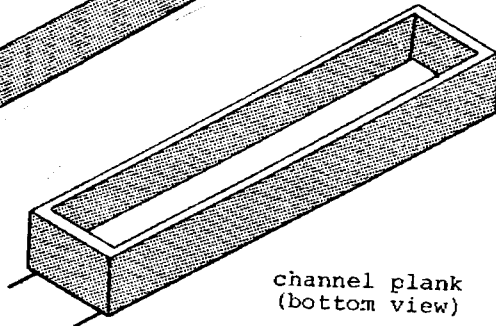

channel plank
(bottom view)

channel planks
in place

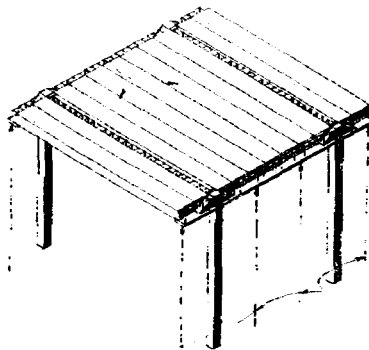

The TOPPING SLAB is a thin layer of concrete cast over the channel-planks after they have been fitted into place. The topping slab finishes the roof, locking the cantilever beams, tie beams, and channel-planks together and providing a smooth surface over them.

The edges of the topping slab are formed by fastening wooden boards around the roof edge formed by the cantilever beams and the two outside channel-planks. There is one topping slab for each module.

An important point should be noted and remembered from the outset. The columns, cantilever beams, and tie beams are joined to each other and to the foundation by large steel bolts and nuts. The bolts are placed through holes in the steel plates which are parts of the various components. The components must be fitted and bolted together to form rigid connections and a stable frame which will resist any movement by the individual members. This can be accomplished only if the workers have carefully followed the directions given in the manual for making steel plates. The instructions for making the steel plates are on pages 40, 68 and 88.

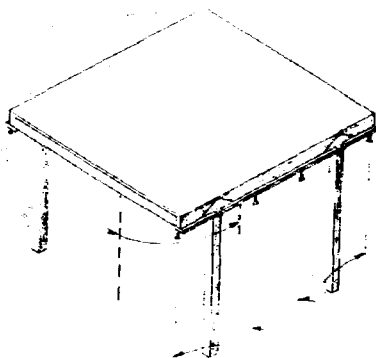

topping slab

joint assembly

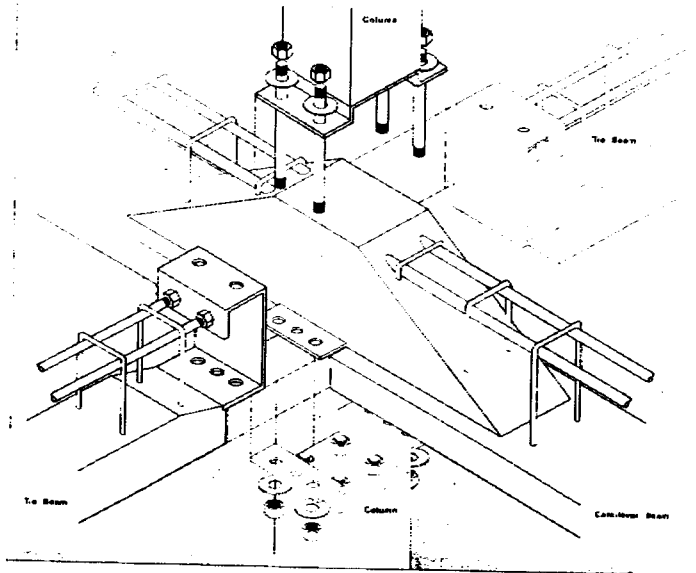

Each joint formed by the components is called, in engineering language, a "moment connection in three dimensions." The structural diagrams on the subsequent pages 10-12a show that in the finished frame, each component (except the channel-plank) is loaded with at least two bending moments. This means that some parts of these components will always be in tension--even the columns. Because concrete alone cannot resist tensile stresses, steel must be placed where tensile stresses are expected. Obviously, this building system will be successful only if the reinforcing cages are built carefully so that steel of the proper size is always placed in the proper position. Therefore, it is emphasized again that the project instructors should make sure that the workers are following the directions accurately at all times.

BUILDING COMPONENTS

BC

NEAL MITCHELL

ADDRESS: NEAL MITCHELL ASSOCIATES, 149 PUTNAM STREET, CAMBRIDGE, MASSACHUSETTS 02139
GENERIC TYPE: SPACE FRAME
NATIONALITY: U.S.
CONTACT NAME: NEAL MITCHELL

TECHNICAL DATA CHART

	WEAT MATERIAL	DESCRIPTION OF FORM	HOW MADE	WHERE MADE	METHOD OF JOINING	INSULATION (WHERE APPLICAB.)	LONGEVITY (ANTICIPATED)	INTERCHANGE-ABILITY	REPLACABILITY (WHERE APPLICAB.)	EXPANSION POTENTIAL	COSTS (DIRECT) (ITEM BY ITEM OR OVERALL)	MAINTENANCE CONTRACT BY BUILDER	CODE PROBLEMS	UNION PROBLEMS	NOTES	
STRUCTURAL	FOOTINGS	concr in situ	caisson	in field	in field	peri-meter w/reqd	in-finite			excel	high vol		none	none		
	SLABS	con-crete	slab on grade	poured in place	in field		"			"	"		"	"		
	FLOORS	con-crete	pre-cast slabs	2" con-crete top'g	in plt in fld	shear convec-tors	roof slabs w/reqd	"	com-plete	"	"	min	"	"		
	COLUMNS	cell'r conc	6" x 4 3/4"	pre-cast	in plant	bolted		"	"	"	"	"	NBS appv'd	"	"	
	BEAMS	cell'r conc	7" x 4 3/4"	"	"	moment connec		"	"	"	"	"	"	"	"	
	ROOF	S A M E A S F L O O R S														
EXTERIOR	WALLS	any weath resis	non-bear panels	assembly	in plt in fld	ramset to frame	rigid	funct of mat'l	"	exclnt bolt-in	funct of mat'l	"	none	"		
	WINDOWS	alumn frame	sldrs	std	factory	std		frame infin	"	exclnt	min	good	"	"		
	DOORS	wood	std	"	"	"		funct of mat'l	"	"	"	"	"	"		
	ROOFING	elasto-meric	liquid		appld in fld			infin	"	exclnt	"	"	"	"		
INTERIOR	STAIRS	wood or steel	std	std	fld/plnt			reasbl	com-plete	"	"	"	"	"		
	PARTITIONS	dry wall	struc-ticor U.S.G.	unique design	factory	driven screws		"	"	"	"	"	"	"		
	DOORS	wood	std pre-hung	std	"	std		"	"	"	"	"	"	"		
	BATHROOM	std fixtra	std	"	"	"		"	"	"	"	"	"	"		
	KITCHEN	std pre-asmbly	tappan group	pre-fab unique	"	"		"	"	"	"	"	"	"		
	INTA. FINISH	wynyl carpet	single sheet	pre-cut	"	mastic		rsnbl	"	"	rsnbl	good	"	"		
MECHANICAL	PLUMBING	P.V.C.	single track	asmbld tree	factory	solvent		infin	"	"	min		resis-tance dwldg	"		
	HEATING	warm air	centrl ductg	std tree	"	gas/elect		"	"	"	"		none	"		
	A/C VENTILATION	air	"	"	"	"		"	"	"	"	"	"	"		
	ELECTRICAL	std surface	surface mounted	strip	"	"		rsnbl	"	"	rsnbl	"	"	"		

THREE DIMENSIONAL PLANNING MODULE

Standard 10' x 12' Bay Size with 3' Cantilevers
 Capability of one to five stories

BUILDING COMPONENTS

BC

LABOR AND ECONOMIC FACTORS

1. SCOPE: (min. no. D.U./yr) a) to amortize construct. equipment b) to sustain econ. plant operation	150 DU FOR MINIMUM CONSTRUCTION 4000 - 5000 DU TO MAXIMIZE PRODUCTION EFFICIENCY AND "LEARNING CURVE" EFFECTS
2. ECONOMIC RADIUS FROM MANUFACTURER'S SOURCE(S)	THREE HOURS BY TRUCK / LANCASTER, PENNSYLVANIA
3. SKILLS EMPLOYED, TRAINING POTENTIAL a) off-site (labor time incl.) b) on-site (incl. labor time)	BASIC CONSTRUCTION SKILLS; TOTAL SYSTEM DESIGNED AS TRAINING DEVICE PLANT TRAINING POTENTIAL OFFERED THROUGH SUB-SYSTEM FABRICATION AND ASSEMBLY ASSEMBLY NEEDS ONLY BASIC SKILLS - HYDRO CRANE NEEDED FOR U.S. SYSTEM ONLY
4. WHAT DESIGN FREEDOMS CAN LOCAL ARCHITECTS MANIPULATE WITHOUT DESTROYING THE ECONOMIC AND PRODUCTION EFFICIENCIES OF THE SYSTEM?	EXTENSIVE MASSING FLEXIBILITY THROUGH STANDARD 10' x 12' BAY SIZE WITH 3' CANTILEVERS. CAPABILITY OF ONE TO FIVE STORIES BY SINGLE CELLULAR ADDITIONS. SUB-SYSTEM SELECTION AND DESIGN (HEATING, PLUMBING, ELECTRIC, WALLS, ROOF) CONTROLLED BY MATRIX DEVELOPED BY SYSTEMS DESIGNERS.

TECHNICAL AND CONSTRUCTION FACTORS

1. SPECIAL ERECTION EQUIPMENT (including topographical requirements)	500 POUND MAXIMUM WEIGHT OF COMPONENTS. ERECTED BY FIELD CREW AND HYDRO CRANE WITH SINGLE OPERATOR.
2. TRANSPORT METHODS - ON & OFF SITE	LESS THAN STANDARD
3. SITE REQUIREMENTS: a. Topography b. Soil bearing capacity c. On-site assembly area required d. On-site storage area required e. Optimum method of const. staging	SYSTEM DESIGNED TO ACCOMMODATE MOST VARIABLES BELL OF FOUNDATION CAISSON VARIES TO ADAPT TO LOCAL SOIL CONDITIONS ASSEMBLED AS FRAME ON SITE - NO REQUIREMENTS MINIMUM - COMPONENTS STACK SIMILARLY TO TIMBER COMPLETE ERECTION MANUAL AVAILABLE FROM DESIGNERS. FOUNDATION, FRAME, HORIZONTAL, AND VERTICAL INFILL.
4. LIMITATIONS ON BUILDING CONFIGURATION: a. Height b. Width c. Varying ext. hts. in same structure d. Unequal floor heights e. Unequal floor spans f. Elevator and/or walkup g. Two means of egress besides elev. h. Interior corridor i. Open access gallery j. Stairwell direct to unit k. Private outdoor space per unit	FIVE STORIES 20' MINIMUM (2 BAYS) SPECIAL CONFIGURATION REQUIRED SPECIAL CONFIGURATION REQUIRED SPECIAL CONFIGURATION REQUIRED BOTH POSSIBLE WITH STANDARD SYSTEM POSSIBLE WITH STANDARD SYSTEM POSSIBLE WITH STANDARD SYSTEM POSSIBLE WITH STANDARD SYSTEM POSSIBLE WITH STANDARD SYSTEM
5. CAN PARKING BE ECONOMICALLY CONTAINED WITHIN BUILDING SYSTEM	UNIT BAY (10' x 12') CLEAR AND FIREPROOF STRUCTURE FACILITIATES THIS PARKING FUNCTION.
6. IN WHAT WAYS CAN THE BUILDING SYSTEM BE COORDINATED WITH OTHER SYSTEMS	SYSTEM IS DESIGNED TO ACCOMMODATE MULTIPLE COMBINATIONS OF SUB-SYSTEMS. FOR INSTANCE: HEATING SYSTEMS FOR SEVERAL FUELS; MULTIPLE WALL MATERIALS (NO BEARING REQUIREMENTS)
7. BUILDING TYPES (USES) COMPATIBLE WITH SYSTEM	SINGLE FAMILY, TOWN HOUSES, APARTMENTS, STORES, MOTELS LIMITATION IS ABILITY OF DESIGNER
8. ON A PSF BASIS HOW DOES SYSTEM COMPARE WITH CONVENTIONAL CONSTRUCTION	IN-CITY PRICES RANGE FROM \$10-\$12 PSF COMPARED TO \$12-\$14 FOR OTHER CONSTRUCTION OF EQUAL VOLUME. DIFFERENCE INCREASES AS LARGER VOLUMES ARE ASSEMBLED.
9. ANTICIPATED COST SAVING a) initial construction cost b) long-term maintenance	
10. SPEED OF ERECTION, TOOLING UP TIME AND PROJECTED TIME SAVINGS	
11. DWELLING UNIT DENSITY RANGE POSSIBILITY OF SCATTERED HOUSING SITES	
12. EXPERIENCE LEVEL OF SYSTEM (where?)	SOUTH AMERICA: VENEZUELA, CIUDAD GUAYANA
13. ZONING, BUILDING AND FIRE CODE COMPLIANCE (D.C.)	
14. LABOR PRACTICES	
15. CONTRACTURAL SYSTEMS FLEXIBILITY	

COMMENTS:

Adapted to U.S. requirements
Prototype, Connecticut
17 DU HUD Grant, Sec. 233, Detroit, Michigan

FOAMED CONCRETE

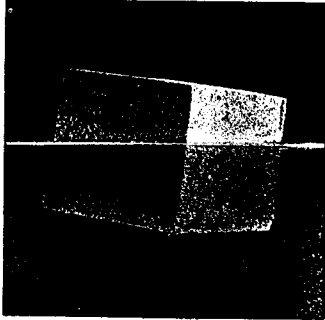

Cellucon is light.



Cellucon is insulating.



Cellucon can be sawn.

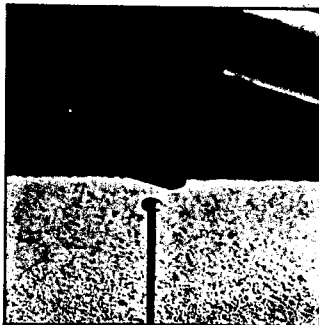

Cellucon can be nailed.

INTRODUCTION

Most architects, engineers and builders would agree that reinforced concrete is one of the best materials in use in the construction industry, yet very few would choose to build their own dwelling house from this material simply because in many areas it is unacceptable.

Most of the disadvantages attributed to reinforced concrete are over-ruled when the construction is from reinforced Cellular Foamed Concrete – even the appearance can quite readily be adjusted to acceptable standards. Over and above this there are certain advantages which in themselves create a demand for cellular foamed concrete construction in industry. The benefits from using cellular foamed concrete are: –

- Rapid and relatively simple construction.
- Simple and inexpensive equipment.
- The concrete as produced is comparable in cost to normal dense weight concrete.
- Due to its light weight, handling and cartage costs less.
- Heat and sound insulation are particularly good giving energy conservation advantages.
- No condensation problems as experienced with normal dense weight concrete.

METHOD OF MANUFACTURE

CELLUCON foamed concrete is formed by entrapping a multitude of small bubbles of air in a cement based mixture by a chemical process. In order to achieve the optimum results using this method research was carried out on the type of machine to produce the foam and also the chemical combination of the foaming agent. Much work has been carried out in determining not only these factors but the best water/cement ratios, water to chemical ratio, for the production of foam giving minimum shrinkage, maximum strength etc.

CHARACTERISTICS OF CELLUCON

CELLUCON foamed concrete is one of the few materials available which has good mechanical strength together with low thermal conductivity and ease of working. Because of the fact that it is produced by adding foam to a cement water slurry its density is infinitely variable as is also its strength. As a material it is very simple to cast into moulds, it is strengthened by effective curing.

- * **THERMAL CONDUCTIVITY** is low and its acoustic properties most desirable.
- * **WATER ABSORPTION** is quite low because of the closed cellular structure. For this same structural reason it takes many months for the centre of a slab or panel cast in foamed concrete to completely dry out and acquire something near its ultimate strength.
- * **TENSILE STRENGTH** of foamed concrete is relatively high, sometimes as much as 25% of its compressive strength. It has the properties of toughness and durability rather than brittleness.

- * **FIRE RESISTANCE:** It is intensely fire resistant and under concentrated heating conditions such as an oxy torch held close to the surface it will not explode and spall as does normal dense weight concrete.
- * **WORKABILITY:** The material can be sawn, sculptured or penetrated by normal building nails, screws, etc.

PROPERTIES OF CELLUCON

1. COMPRESSIVE STRENGTH

The compressive strength of foamed concrete is influenced by many factors such as density, age, moisture content, the physical and chemical characteristics of component materials and the mix proportions. If the aggregate mix, type of cement and method of manufacture are kept constant a certain relationship exists between the density and the strength but any change to the factors mentioned above will vary that relationship quite markedly. For example, by changing the type of cement a variation of 30 or 40% is quite common.

Using CELLUCON foam added to cement or to a sand/cement mix, a typical relationship of density to compressive strength is shown in Table 1.

The compressive strength can be increased by up to 100% through effective and special curing methods over the first two months. Moist curing continuously has a profound effect on increasing the compressive strength. For small components such as foamed concrete building blocks it is common to cure them by means of high pressure steam in an autoclave. This increases the compressive strength by 100%. In autoclave curing it is an advantage to have the addition of lime and silica flour in the mix as the hydrated lime reacts with the finally divided silicious aggregate and forms mono calcium silicate hydrate.

2. TENSILE STRENGTH

Depending on the method of curing, the tensile strength of foamed concrete can be as high as 0.25 of its compressive strength with a strain of around 0.1% at the time of rupture.

3. SHEAR STRENGTH

Generally the shear strength varies between 6% and 10% of the compressive strength. Shear reinforcement is seldom required in flooring and roofing units.

4. SHRINKAGE

Lightweight cellular concrete like all cement materials has a shrinkage phenomena during the setting stage. The amount of the shrinkage is dependant upon various factors e.g. type of cement, type of curing, size and quality of sand, amount of cement in the mix, density of foamed concrete etc.

The worst extent of shrinkage takes place during the first 28 days after which time it is negligible. During the first 28 days if the conditions of manufacture of the foamed concrete are well controlled, shrinkage can be kept to the order of 0.06%.

5. EXPANSION

The co-efficient of linear expansion for CELLUCON foamed concrete is of the same order as that of normal concrete, i.e. 0.000009 per degree centigrade. This factor becomes important when using foamed concrete on large areas of roof slabs, which are exposed to heat and cold.

6. SOUND INSULATION

The sound absorption capacity of CELLUCON foamed concrete is much better than for normal dense weight concrete masonry. For this reason it is popularly used in partition walls and as an insulating layer on structural concrete slabs to restrict noise transmission from floor to floor.

TABLE 1
COMPRESSIVE STRENGTHS FOR CELLUCON
FOAMED CONCRETE

DENSITY Kg/m ³	SAND: CEMENT RATIO	7 DAYS MPa	28 DAYS MPa	12 MONTHS MPa
300	0:1	0.3	0.7	1.2
400	0:1	0.8	2.0	3.8
500	0:1	2.0	4.5	8.0
600	0:1	3.5	8.0	14.0
	1:1	0.8	2.0	3.5
700	1:1	1.4	3.5	6.0
800	1:1	2.5	6.0	11.0
	2:1	1.4	3.2	6.0
1,000	2:1	2.2	5.2	10.0
1,100	2:1	3.8	8.5	16.0
	3:1	3.0	7.0	13.0
1,200	3:1	4.0	10.0	19.0
1,400	3:1	8.0	18.0	29.0
	4:1	6.0	13.0	24.0
1,600	3:1	12.0	25.0	40.0
	4:1	9.5	19.0	34.0

TABLE 2

Concrete Density kgs per m ³	λ	K at Selected Concrete Thicknesses						
		50	80	100	120	150	180	200
300	0.065	1.03	0.70	0.58	0.49	0.40	0.34	0.30
400	0.08	1.21	0.83	0.69	0.59	0.48	0.41	0.37
500	0.095	1.38	0.96	0.8	0.69	0.56	0.48	0.43
600	0.115	1.57	1.12	0.93	0.81	0.67	0.57	0.52
700	0.13	1.23	1.03	0.89	0.74	0.63	0.58	0.47
800	0.15	1.37	1.15	1.00	0.83	0.71	0.65	0.54
900	0.175	1.52	1.30	1.13	0.94	0.81	0.75	0.61
1.000	0.205	1.69	1.45	1.27	1.07	0.94	0.85	0.70
1.100	0.23	1.82	1.57	1.39	1.17	1.02	0.94	0.78
1.200	0.27	2.02	1.75	1.55	1.32	1.15	1.06	0.98
1.400	0.346	2.31	2.04	1.83	1.58	1.39	1.28	1.08
1.600	0.436	2.06	2.33	2.10	1.04	1.63	1.52	1.29

λ = Thermal Conductivity Coefficient
 K = Thermal Transmission Coefficient

7. THERMAL INSULATION

This is one of the characteristics of CELLULON foamed concrete which is prominent in order of importance. With the promotion of energy conservation in buildings it has become one of the most interesting materials in the insulation field.

Table 2 shows the relationship between the thermal conductivity and various densities. The table shows the thermal transmission co-efficient for various densities of both cement and sand mixes as well as mixes containing cement and foam only.

The high insulating value of the material becomes particularly important in avoiding condensation from atmospheric humidity arising as the result of changes in ambient temperature. Not only is this important in dwellings but also in pigsties and stables where insulation has proven itself as an aid to the health of particularly new born livestock.

8. FIRE RESISTANCE

Because of its insulating properties the resistance to transmission of heat by fire is extremely

high. Furthermore, the application of intense heat does not cause the concrete to spall or explode as is the case with normal dense weight concrete. The result of this is that the reinforcing steel remains cool and protected for a much longer period. Some typical fire resistance ratings are listed below:

FIRE RESISTANCE RATING

Unit	Thickness (mm)	Rating (h)
Nonloadbearing wall of blocks	65	2
Loadbearing wall of blocks	100	2
Reinforced roof slabs with 12mm cover to reinforcement	125	2
Nonloadbearing wall of storey—height partition panels	75	2
Nonloadbearing wall of horizontal reinforced wall panels	150	6

Tests and certificates from various authorities indicate that 150mm of cellular foamed concrete is adequate for 4-hour fire rating.

The requirements for some specific authorities for 4-hour rating indicate:—

Italy 133mm

New Zealand 133mm

Australia (EBRS—Ryde) 105mm

THE MEARL CORPORATION

220 WESTFIELD AVENUE, WEST

P.O. Box 208, Roselle Park, New Jersey—Area Code 201 - 245-9500

STRUCTURAL AND NONSTRUCTURAL MEARLCRETE CONCRETE APPLICATIONS AND PROPERTIES

LOW DENSITY - CAST-IN-PLACE

The following applications are primarily nonstructural and generally require low density concrete (16 to 35 pcf). Wherever the material is to be subjected to wear, it must be covered with a more abrasion resistant material.

1. Insulating Concrete Roof Decks with 2 Hour Fire Rating
2. Roof Insulation, Leveling and Drain Slope Fill
3. Multistory Floor Fill and Utilities Embedment Over Cellular Steel, Short Span Concrete Arches and Reinforced or Prestressed Slabs
4. Cavity Wall Insulation for Refrigerated Warehouses and Other Nonresidential Structures
5. Firewalls -- Pumped between Installed Housing Modules
6. Fireproofing of Structural Steel
7. Bedding and Backfill for Uniform Support of Large Diameter Pipelines and Buried Tanks, Foundations and Fill for Fiberglass Reinforced Plastic or Steel Tanks, above and below grade
8. Underground Pipe Insulation for Hot and Cold Lines
9. Slab on Grade Insulation
10. Tunnel Liner Grout and Fault Fill
11. Lightweight Cement for Well Casings
12. General Void Fill such as for Abandoned Sewer and Other Pipelines, Tunnels and Underground Fuel Tanks
13. Insulation for Cryogenic Storage Tanks for Refrigerated Liquefied Gases
14. Impact, Blast Explosion and Seismic Energy Absorption and Shock Mitigation Barriers, Highway Crash Cushions, Cavity Fill for Blast Attenuating Walls, Industrial Safety Walls Resistant to Shattering and Fragmentation.

For large volume applications, the cast-in-place low density concrete is best made in continuous equipment. One such machine is known as a Mobile Mearlcreter. This continuously mixes water and cement into a slurry, forms the foam, blends foam and slurry and then pumps the fluid foam concrete through flexible hoses into place where it hardens. For small scale production, Mearlcrete concrete may be batch mixed and placed by pump or by buggies or wheelbarrows.

LOW DENSITY - PRECAST

1. Insulating Blocks or Slabs for Concrete or Masonry Wall Back-up
2. Insulating Cores for Tilt-up Factory Prefabricated Sandwich Panels
3. Roof Deck Planks and Tiles
4. Fireproofing Panels and Assembled Fire Walls

Products of this type when cured conventionally at ambient temperature and pressure are limited to rather small size members due to their relatively low strength and high shrinkage.

When cured at high steam pressures in an autoclave, the foam concrete is chemically altered so that it is "preshrunk" and the strength markedly increased. This opens up a completely new market for lightweight products which may be simultaneously both structural and insulating. We have developed a completely engineered plant and process which, like autoclaving, also results in very high strength to density ratios. Further inquiries on licensing either of these processes are welcome.

MATERIALS

Low density foam concrete is best made with preformed foam. Both cast-in-place and precast products may be made from cement alone or mixtures of cement and light aggregates such as perlite, vermiculite or expanded shales and clays.

The use of some aggregate or fibers, including specially coated glass fibers, while generally increasing the cost, also increases the stiffness of the mix, imparts greater tensile strength and makes it possible to use cast-in-place foam concrete on steep slopes which would not otherwise be possible with only fine cement and sand. These fibers are also useful in the production of conventionally cured low density precast wall panels.

STRUCTURAL CONCRETE - CAST-IN-PLACE

1. On permanent Steel Forms or Temporary Wood Forms in Multistory Floor Construction
2. Air-borne Sound Insulating Floor Fill in Residential Apartment Construction
3. Fireproofing of Structural Steel
4. Pumped-in-place Monolithic Load-bearing Walls, Floors, Roofs and Foundations for Low Cost Housing, Simulated Masonry
5. Pumped Grout for Tunnel Construction and Backfilling

All of these applications take advantage of the fluidity of foam concrete in the higher density range, from 75 to 120 pcf. Not only are they also lighter than conventional stone concrete thereby making possible a reduction in the weight of the supporting structure, but they are quite fluid and readily pumped with the most common pumps now being used for concrete. This high degree of pumpability and resulting reduction of placement labor costs is a major cost saving factor for this type of material.

These products are generally made by first mixing cement, sand and water in a transit mixer, mortar mixer, or other conventional concrete mixer and then adding a predetermined amount of foam from a generator to give the required density. After blending, the fluid mix may be pumped into place. For some applications including cast-in-place monolithic housing, combinations of lightweight aggregates with foam concrete result in very desirable properties.

STRUCTURAL CONCRETE - PRECAST PRODUCTS

This cellular concrete category has been until now comprised primarily of steel mesh reinforced wall, roof and floor planks, 2 to 3 inches in thickness, usually in the 75 to 100 pcf density range. Normally these are cast in flat or gang molds and cured, either in low pressure steam followed by air curing, or simply moist-cured. Such slabs may be either flat slabs or channel slabs and may be made from foamed sand-cement mixes with or without lightweight aggregate or with grits (bank run pea gravel) as an aggregate. More recently, precast columns and beams made from cellular concrete have been used for building systems for housing and other light occupancy. With advancing technology, cellular concrete will soon be used for many types of structures utilizing precast concrete. For example, complete precast rooms for housing and motel construction have been produced from prestressed foam concrete cast in special room size molds.

Actual mix proportions, curing procedure, reinforcement and dimensions of the members are determined by the span desired by the architect and the required floor and roof loading and other engineering considerations.

The above referenced proprietary continuous process of achieving high strength to weight ratios is particularly suited to production of panels, columns, beams, wall sections and other components for systems building.

PROPERTIES OF FOAM CONCRETE

Compressive Strength - Varies from 50 psi to 4000 psi. In common with other types of concrete, at constant water/cement ratio the compressive strength of cellular concrete will vary with the cement factor so long as the density is held constant. Therefore at a given final density, the strength can be increased simply by increasing the cement content prior to adding the foam. At any given proportion of cement, aggregate and water, the compressive strength varies directly with density or inversely with the foam content.

Thermal Conductivity, or "k" factor, varies only with density. The attached data sheet (FC-707) illustrates the quantitative relationship.

Drying Shrinkage - As with all concretes, the drying shrinkage increases with the cement factor. For low density insulating concretes used in roof decks and lightweight fills, this is about 0.2 to 0.6%. The higher density concretes in the 100 pcf range have a drying shrinkage about 0.06%, again depending somewhat on the cement factor, the fineness modulus of the sand, the type of aggregate and the water/cement ratio.

Modulus of Elasticity - The modulus of elasticity, E_c is the modulus at $0.5 f'_c$, that is at one half the compressive strength. In lieu of test data for any given mix it may be calculated by means of the formula (from ACI-318-63)

$$E_c = 33w^{1.5} f'_c 0.5$$

in which w is the oven dry density of the concrete.

Thermal Expansion - The linear coefficient of thermal expansion is similar to that for steel, between 5 and 7×10^{-6} , so that it may be reinforced in the same manner as conventional concrete, using mesh, reinforcing bars or proprietary embossed galvanized steel forms.

Durability - In freeze-thaw stability, cellular concretes show markedly superior durability for either precast or cast-in-place wall construction. The low density material has also been tested at extremely low temperatures for cryogenic applications and will withstand thermal shock with liquid nitrogen. When used for light residential pavements or sidewalks, cellular concrete at densities of 100 pcf have proven far more resistant to the effect of salts than conventional sand and gravel concretes.

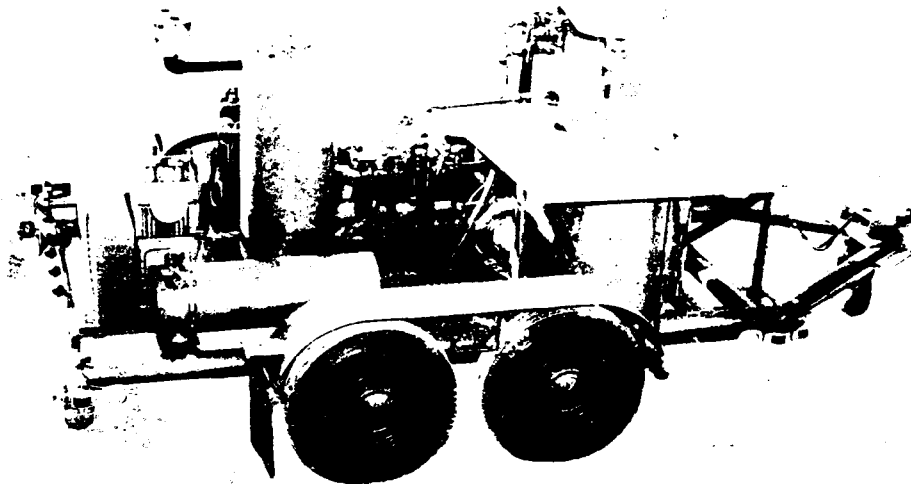

MOBILE MEARLCRETER

Model 25H



CELLULAR CONCRETE

Specifications of cellular concrete mix composed of: cement 340 kg ha/m³
sand 0-2 mm granular size

Mortar density, in kg/m ³		600	900	1200	1500
Compressive strength	in N/mm ²	1.5	3.5	6	9
Bending tensile strength	in N/mm ²	0.06	0.17	0.32	0.51
E modulus (static)	in N/mm ²	931	2023	4362	6205
E modulus (dynamic)	in N/mm ²	270	751	1943	3067
Heat conduction coefficient	in W/mk	0.11	0.21	0.37	0.49
Density, dry vs mortar	in %	88	90	91	92
Density, soak-up vs mortar	in %	99	97	95	94
Density, full immersion vs mortar	in %	110	106	103	101

The above values were found using the following test techniques

Compressive strength	NEN 3880 (VB 74-84) (Art. A 606.6.1)
Bending tensile strength	DIN 1048 sheet 1 Art. 4.3.1.3
E modulus, static	NEN 3880 (VB 74-84 Art. 9.609.2)
E modulus, dynamic	via tensile strength
Heat conduction coefficient	Showa-denko heatflowmeter, measured in dry state (105°C) as % vs mortar
Density, soak-up	Cube, 158 mm ³ , in 5 cm of water, to constant weight as % vs mortar
Density, water absorption	Cube, 158 mm ³ , immersed to constant weight as % vs mortar

Materials

Cement: blast furnace A (ha)	NEN 3550
Sand: 0-2 mm granular size	NEN 3542
Water	NEN 3880
Aggregates	NEN 3532 - 3533
Foaming agent	VOTON Protein foam

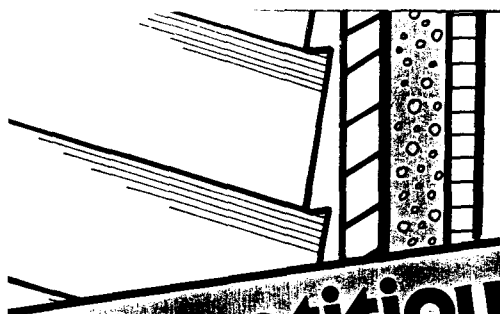

AIR-KRETE®

cementitious foam insulation

• Non-Toxic • Water-Resistant • Non-Combustible • Easily Installed • Inorganic

PRODUCT PRESENTATION

AIR KRETE® is an ultralight cementitious foam insulation that is being marketed, following four years of intense research and development, as a viable alternative to urea formaldehyde and other foamed-in-place insulation products. Air Krete contains no formaldehyde or asbestos, and has the appearance of foamed cement plaster. Air Krete's unique fire characteristics make it the product of choice in every application where exposure to high temperatures is a factor of concern. Air Krete is distributed via a network of licensed manufacturers and trained local contractors/installers.

INSTALLATION

Air Krete is a combination of two components which, when expanded with compressed air, produce a foam primarily designed for installation in cavity fill applications. Air Krete can be installed in any cavity through a 1"-3" diameter hole, and its flow properties assure confidence in filling all voids. Bulgy or cracked walls, due to product expansion, are eliminated because Air Krete does not expand after leaving the application equipment. This is an all weather installation process, and the quality of the product is not affected by ambient temperatures.

MANUFACTURER

Air Krete, Inc., was founded as an R & D Company working toward innovative concepts in energy conservation. This work resulted in major new technology to the insulation industry in the form of Air Krete cementitious foam insulation products, for which patent applications have been filed. Air Krete, Inc., has elected to license manufacturers for its products on a local and/or regional basis to help assure quick response to architectural and engineering questions. These manufacturers support and maintain a steady flow of component materials to the local contractor/installer.

CONTRACTORS/INSTALLERS

Contractors/installers are fully trained by the licensed manufacturers to apply Air Krete cementitious foam insulation. Continual technical assistance and technical improvements are provided by the licensed manufacturers in methods of installation and equipment for installation.

OVERALL PRODUCT IN PLACE

THERMAL PROPERTIES

Air Krete was tested by Dynatech R/D Company in Cambridge, MA to determine the apparent thermal conductivity and thermal resistance of the product, utilizing ASTM C518-7⁽¹⁾.

SAMPLES CONSISTED OF:

1) The standard 2 lbs/ft³ density (actual 2.07 lbs/ft³).

2) Twice the standard density⁽²⁾ (actual 3.88 lbs/ft³).

3) Three and one half times the standard density⁽³⁾ (actual 6.86 lbs/ft³).

The Test Results Were As Follows:

DENSITY @ 24° (75°F)	K FACTOR	R FACTOR
2.07 lbs/ft ³	.257	3.9
3.88 lbs/ft ³	.304	3.3
6.86 lbs/ft ³	.467	2.1

⁽¹⁾ASTM C518-76—steady state thermal transmission properties by means of heat flow meter.

⁽²⁾⁽³⁾The higher density products are for special applications where substantial increases in structural integrity are needed, and the desired thermal performance can be obtained by increasing the thickness of the material.

FIRE RATINGS AND GASEOUS BY-PRODUCTS ANALYSIS

Air Krete was tested by the Hardwood Plywood Manufacturers Association, Reston, VA to determine surface burning characteristics utilizing ASTM E-84-81A twenty-five foot.

TUNNEL FURNACE TEST METHOD ⁽¹⁾	THE RESULTS WERE:
flamespread factor ⁽²⁾	0
fuel contributed factor ⁽²⁾	0
smoke density factor ⁽²⁾	0

Air Krete was subjected to both smoldering and flaming test conditions to assess the gases released. The NBS-Aminco Smoke Density Chamber and an abridged version of ANSI/ASTM E-862 was utilized for this testing. The results⁽²⁾ were as follows:

TYPE OF GAS	GAS ANALYSIS — PPM (Parts Per Million)		
	SMOLDERING	FLAMING	TLV ⁽³⁾
1) Hydrochloric Acid HCL—Hydrogen Chloride	1.5	4.5	5
2) Hydrocyanic Acid HCN—Hydrogen Cyanide	0	0	10
3) Hydrogen Fluoride HF	0	0	3
4) Nitrous Fumes NO & NO ₂	0	3.5	5
5) Carbon Monoxide CO	10	125	50
6) Carbon Dioxide CO ₂ (% by Volume)	.1	1.1	.5
7) Sulphur Dioxide SO ₂	.25	.65	2

These test results⁽²⁾ demonstrate that Air Krete will not add significantly, if at all, to these potentially hazardous gases when exposed to smoldering or flaming conditions.

⁽¹⁾The normal 10 minute test was extended to 30 minutes with no further flame progression.

ROOFING OVER ELASTIZELL CONCRETE

APPEARANCE: Roofing should begin when the deck can withstand foot traffic. This is usually 1 to 2 days after the ELASTIZELL has been placed. The ELASTIZELL should not be left exposed for longer than 5 to 7 days. The presence of cracking is not detrimental to the roofing system.

DRAINAGE: The recommended slope for positive drainage is 1/4" per foot. Minimum recommended slope is 1/8" per foot.

BASE SHEET: The first ply in a built-up roofing system will typically be the roofing manufacturer's recommended base sheet nailed to the ELASTIZELL roof deck. For single-ply roofing systems, consult with the manufacturer for recommended applications.

BASE SHEET ATTACHMENT: The base sheet should be nailed to the ELASTIZELL concrete deck. Roofing may proceed when the ELASTIZELL concrete is dry and the fasteners hold as required. Acceptable mechanical fasteners (supplied by the roofer) include the following:

ES Nail-Tite® Mark.III
by ES Products
Standard nail pull resistance . . . 40 lbs.

RE-ROOFING WITH ELASTIZELL CONCRETE

ELASTIZELL concrete may be applied directly over existing built-up-roofing in re-roofing or drainage correction applications. This avoids removal of the existing built-up-roofing and the accompanying threat of damage to the building's contents. Request "Re-Roofing with ELASTIZELL" for more details.



An ELASTIZELL Insulating Roof Deck provides a smooth base for the roofing application.

This includes built-up roofing and single-ply ballasted, fully adhered, or torch applied roofing (as illustrated here).

Tapefast Systems by Berryfast, Inc.
Standard staple/tape pull resistance . . . 25 lbs.
Nail and staple/tape pattern per roofing manufacturer's recommendations.
UL Class 90—Wind Uplift—Construction No. 155 (ELASTIZELL Concrete)
Factory Mutual Approval Guide
Class I Roof Deck Construction
J.I. 1GOA4.AM-March, 1982

VENTING: Depending on the building's geographic location, design, and type of occupancy, top-side venting should be considered by perimeter venting at the flashing and/or manufactured stack vents. Consult your local applicator for recommendations. Perimeter venting, cant strips, stack vents, etc., are provided by the roofer. **Special bottom-side venting provisions are not required with ELASTIZELL concrete over any substrate.**

PERIMETER VENTING: Whenever possible, perimeter venting at the flashing should be designed as part of the roof system.

STACK VENTS: If the distance to perimeter venting is greater than 50 feet and/or the ELASTIZELL insulating concrete has an average thickness greater than 5 inches, stack vents should be considered. Consult with roofing manufacturer for recommendations.



BUILT-UP ROOFING SYSTEMS: Major roofing manufacturers accept ELASTIZELL insulating concrete roof decks. If you have any questions about specific applications, please contact the ELASTIZELL CORPORATION for current details.

SINGLE-PLY ROOFING SYSTEMS: Elastomers (EPDM) may be loose laid ballasted or fully adhered to the ELASTIZELL. Modified Bitumens are torch applied to either a nailed base sheet or a primed deck. Contact the ELASTIZELL CORPORATION for current details.



BEFORE: Ponded water on roof decks leads to membrane and insulation deterioration and subsequent leaks.

AFTER: Slope-to-drain ELASTIZELL corrects drainage problems, increases roof system insulation, and provides a solid base for the new roofing.



Strong's new Cellumatic® foam system is a one man operation.

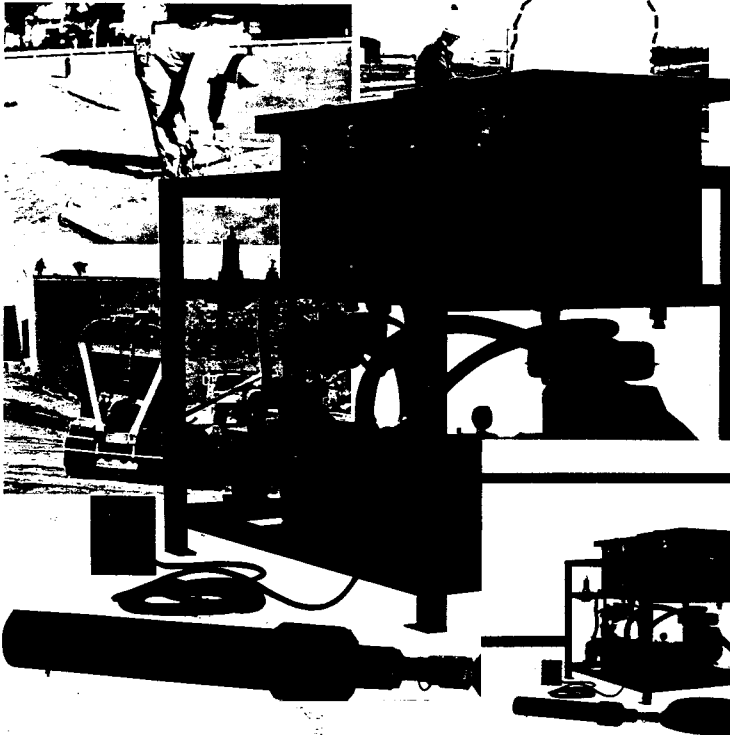

Cellumatic® makes cellular concrete the better way to pour.

By injecting a stable foam into a cement slurry while the mix is being agitated, you get an easily workable cellular concrete that provides many advantages.

It's lighter. The lighter weight of cellular concrete means more coverage at less cost. It's perfect for roofs, walls, floors and panels. And, lighter weight means savings in foundations, and supporting structure design.

Provides better insulation. Thousands of tiny air bubbles created by the new Cellumatic® provide excellent thermal insulation properties in the concrete. Plus, this insulating property reduces transmission of airborne impact noise much better than solid construction materials.

Easy to work with. Cellular concrete is easy to work with during construction. And the finished product is also very workable—you can nail it, cut it, and shape it with ordinary manual or power tools. The new Strong Cellumatic® is the new way to make cellular concrete better than ever before.

Compare the new Cellumatic® with other foam systems.

	Brand "X"	Brand "Y"	Strong's Cellumatic®
DeckMate operator generates foam only as needed without downtime	No	No	Yes
Runs up to 4 hours without charging (instead of every 30 minutes)	No	No	Yes
Can be powered off DeckMate hydraulics	No	No	Yes
Avoids waste - Mixes solution only as needed	No	No	Yes
Recommended for use with all concentrates	No	No	Yes
Pressure vessels required	Yes	No	No
Requires tank bleedoff before recharge	Yes	No	No
Requires smaller air compressor	No 45 G.P.M.	No	Yes 57 G.P.M.
Solution premixing required	Yes	Yes	No
Pumps concentrate from drum storage	No	No	Yes
Vary foam weight by turn of a knob	No	No	Yes
Offers multiple power supplies	No	No	Yes
240 G.P.M. output with one unit	Yes	No	Yes

You've seen the facts and they add up to big advantages for you with the new Cellumatic®. Call Strong today!

INSULATING CONCRETE ROOF DECK SYSTEM

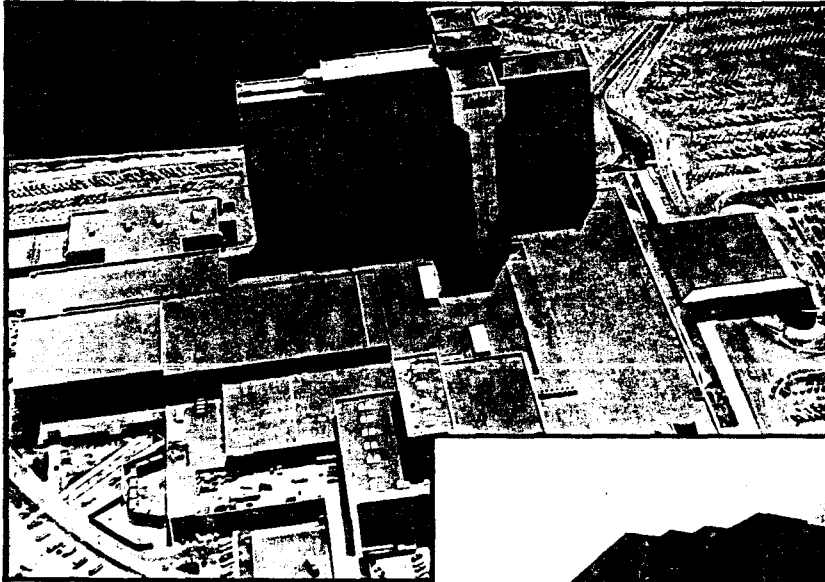

MGM GRAND HOTEL in Reno, Nevada.



NCR WORLD HEADQUARTERS
in Dayton, Ohio.

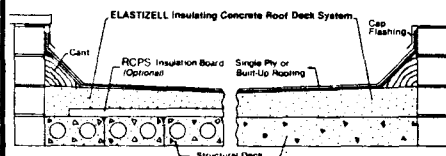
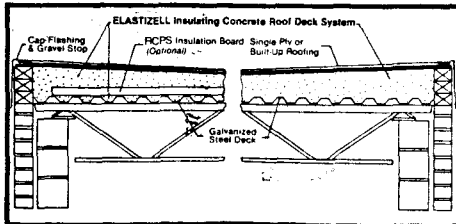

NOTE: Range II is the recommended range for roof decks.

	Air Dry Density (pcf)	Oven Dry Density (pcf)	Cast Density (pcf)	28-Day Compressive Strength minimum f'_c (psi)	R Value
RANGE IA	21-27	16-20	26-34	40	1.84
RANGE IB		20-24		80	1.58
RANGE IIA	27-32	24-28	34-42	160	1.34
RANGE IIB		28-32		200	1.20
RANGE IIIA	32-40	32-38	42-50	250	1.00
RANGE IIIB		38-44		300	0.86

Note: Thermal conductivity is based on the minimum dry density measured at a mean temperature of 75°F.

R-VALUES FOR VARIOUS MATERIALS (Whenever possible, consult specific manufacturer's literature.)

1/2" plywood	0.62	1-1/2" polystyrene board	6.00	air space (heat flow up-winter)	0.94
3/4" plywood	0.93	1" polystyrene board	4.00	air space-winter-reflective surface	1.90
1/2" gypsum board	0.45	1" urethane—sprayed on, 3 pcf	7.14	air space (heat flow down-summer)	1.23
5/8" gypsum board	0.56	1" fiberboard	2.78	air space-summer-reflective surface	3.74
1/2" acoustical tile	1.25	3/4" plaster	0.15	1" Foamglass insulation	2.63
3/4" acoustical tile	1.89	1" poured perlited gypsum	0.87	15/16" Fiberglas® Roof Insulation	3.70
2" polystyrene board	8.00	1" perlite board	2.78	1-5/16" Fiberglas® Roof Insulation	5.26

Sources: ASHRAE Handbook of Fundamentals and manufacturers' values.

The average thickness for a roof deck sloped to an inside drain:

$$\begin{aligned} \text{Average Thickness} &= 2/3 (\text{HiPt.} - \text{LoPt.}) + \text{LoPt.} \\ &= (2\text{HiPt.} + \text{LoPt.})/3 \end{aligned}$$

OWNER OR LABOR BUILT FOUNDATION

Easy Installation

The IDR Footer Block system goes together dry without the use of formwork, without long concrete chutes, and without a lot of expensive labor. All that is required is a solid soil base which can be roughly leveled off with gravel, mortar, or lean concrete.

Once the excavation is prepared, simply establish the corner points and string a line between them. Working from the corner units, interlock the stretchers, completing the leveling process as you go. Final leveling is accomplished with the mortar bed receiving the first foundation wall course over the IDR Footer Block keys.

IDR Footer Block Foundations are Reinforced in Earthquake Areas.

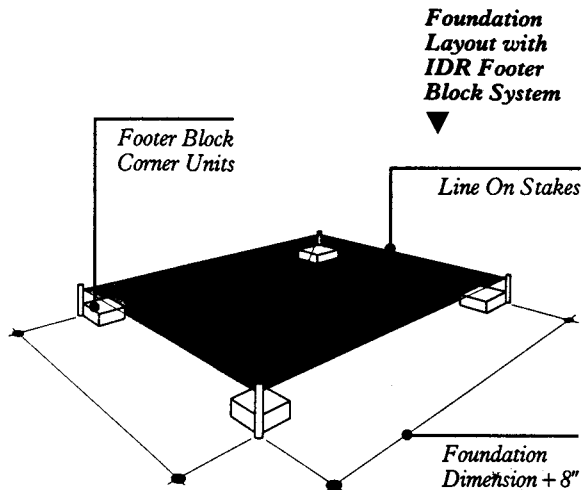
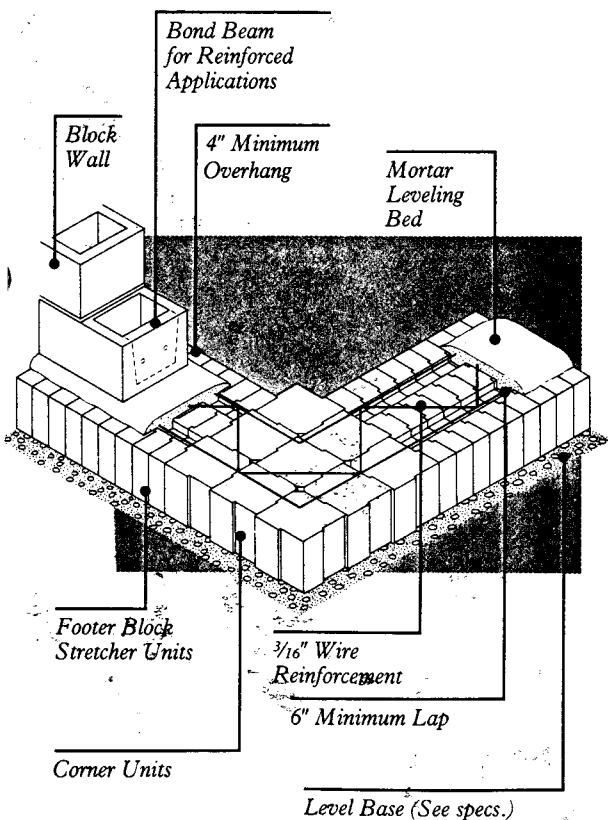

A Variety of Cost-Saving Applications

- **Difficult Access Sites**
IDR Footer Block saves time usually spent setting up access for ready-mix trucks around excavations, trees, houses and fences.
- **Greenhouses and Sunrooms**
IDR Footer Block is great for additions and remodeling jobs such as family rooms, garages, and hot-tub enclosures.
- **Residential Jobs**
IDR Footer Block is economical for foundation walls and basements in single and multiple units.
- **Low-rise Commercial**
IDR Footer Blocks permit rapid layout and construction of malls, office condominiums, warehouses and manufacturing buildings.

A Proven System

Similar systems have been in use for decades in Europe, Canada, and Japan, but there the similarity ends... because IDR Footer Blocks have been designed to American standards and codes.

Their proprietary design includes two-way interlocks, shear keys and integral corner units which can be put together to form column piers and footings. The IDR Footer Block system also provides for horizontal reinforcing and dowels if required.

BUILDING COMPONENTS

BC

EARTH AND AGRICULTURE-BASED BUILDING MATERIALS

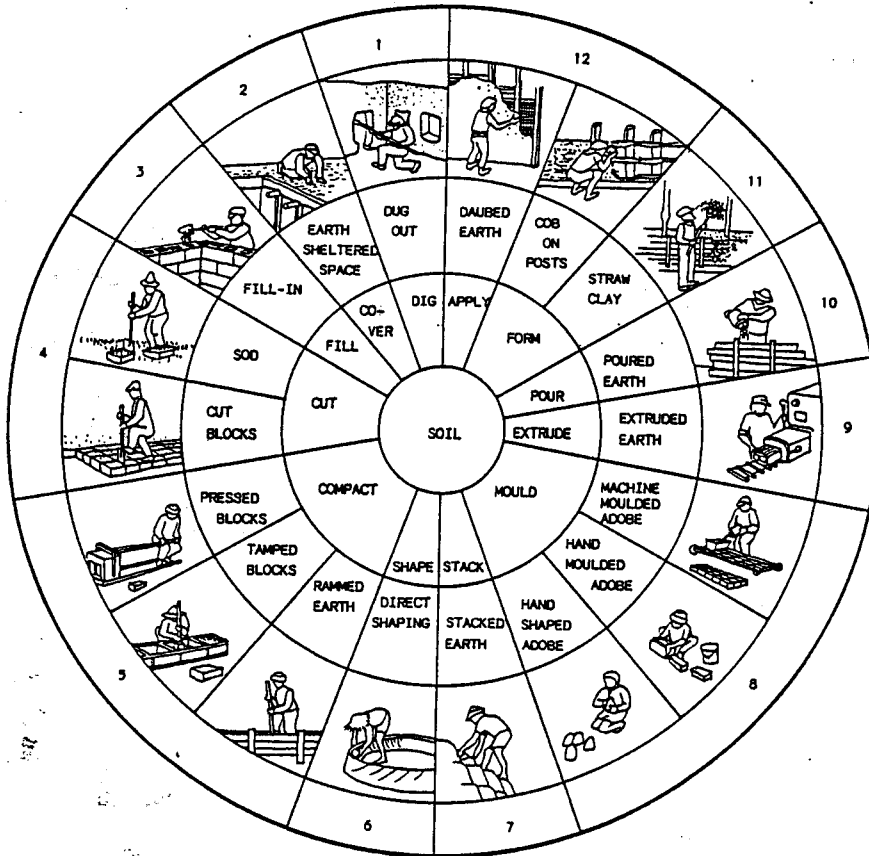

BUILDING COMPONENTS

BC

PUDDLE EARTH BLOCK MANUFACTURING

ADUBE : MANUAL PRODUCTION

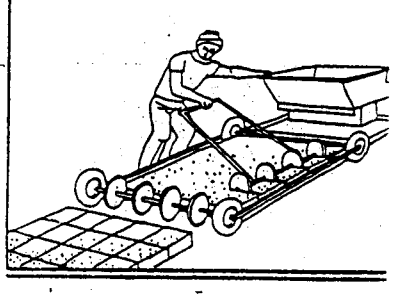
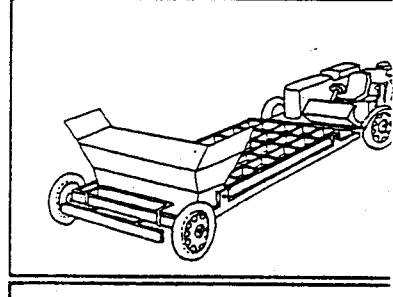
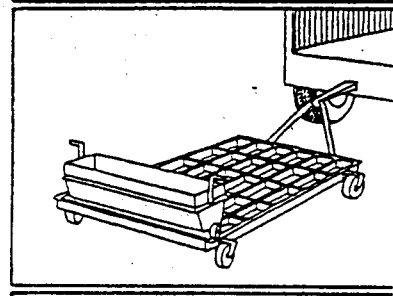
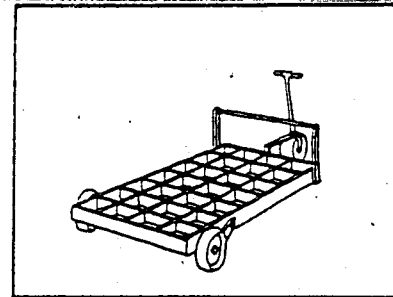
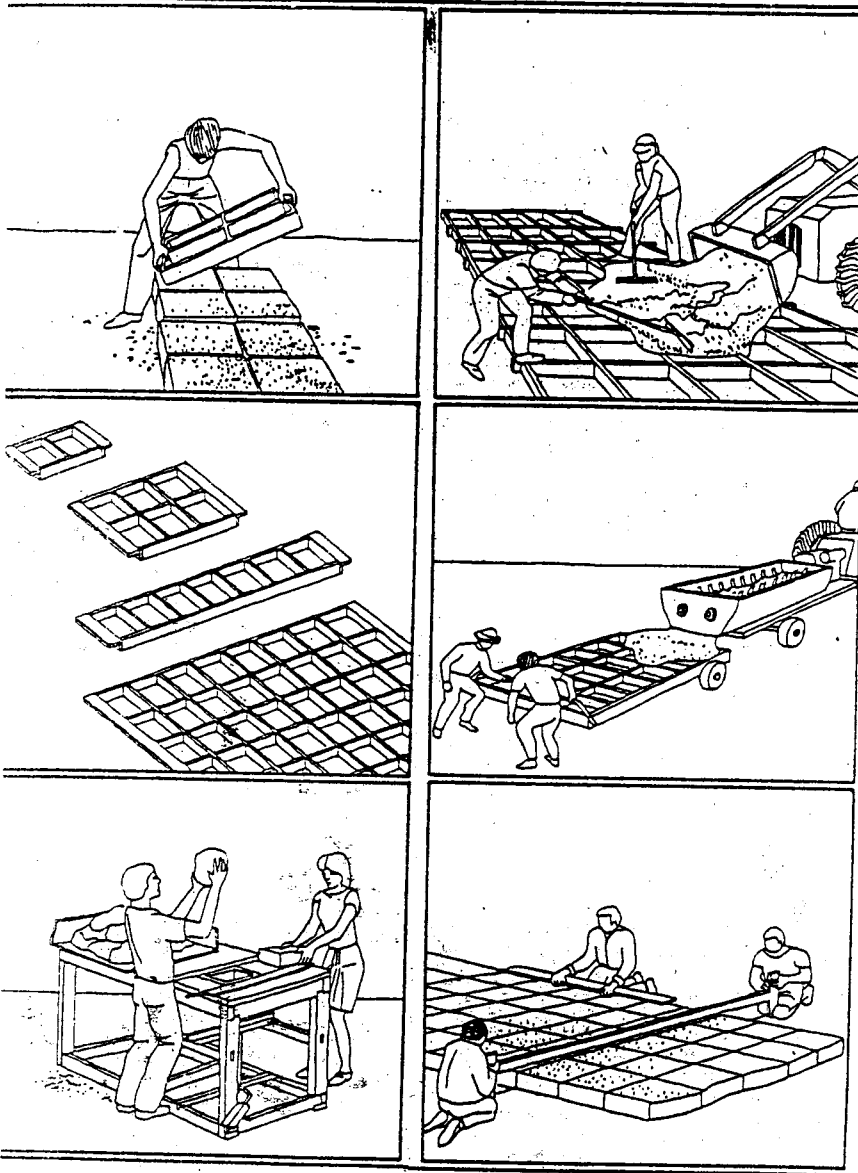

BUILDING COMPONENTS

BC

PRESSED EARTH BLOCK MANUFACTURING

COMPRESSED BLOCKS : MOTORIZED PRESSES

SEMI TERSTAMATIQUE

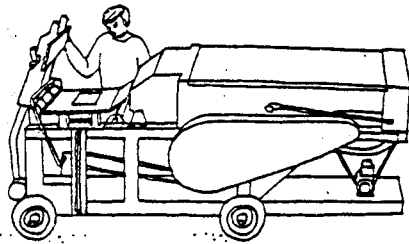

UNIPRESS

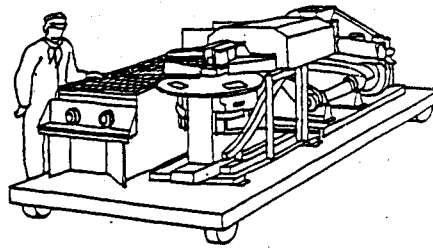

PACT 500

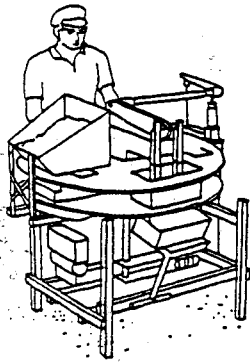

AL NIBLACK

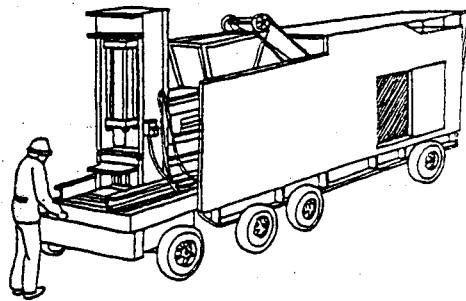

CERAMATIC

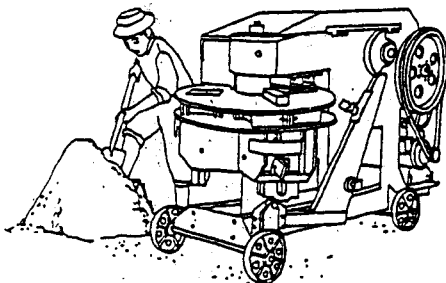

TERCC

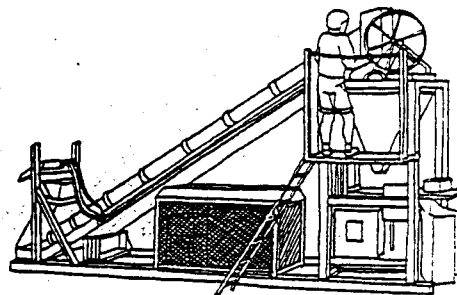

COMPRESSED BLOCKS : INDUSTRIAL PRODUCTION UNITS

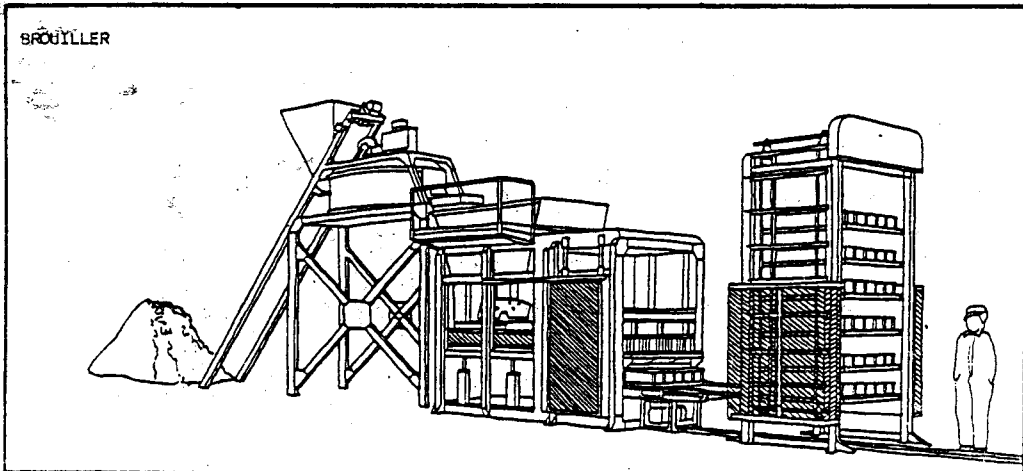
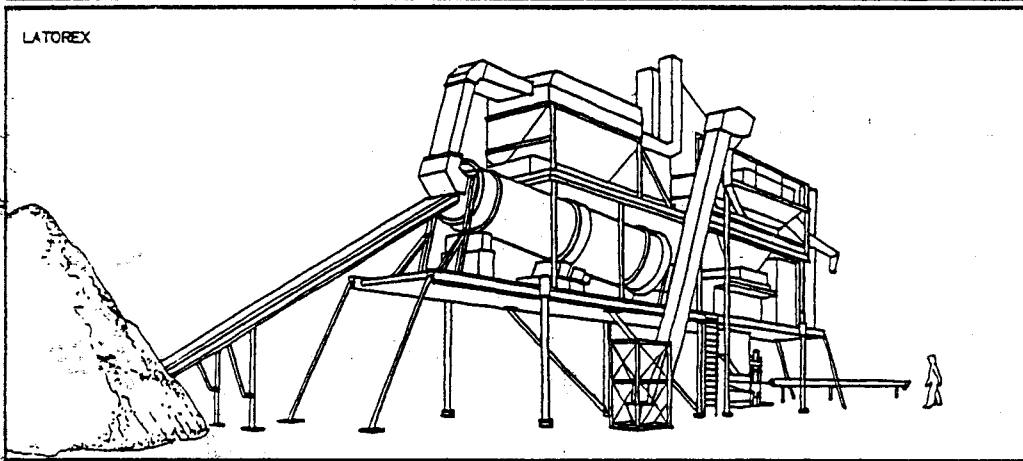
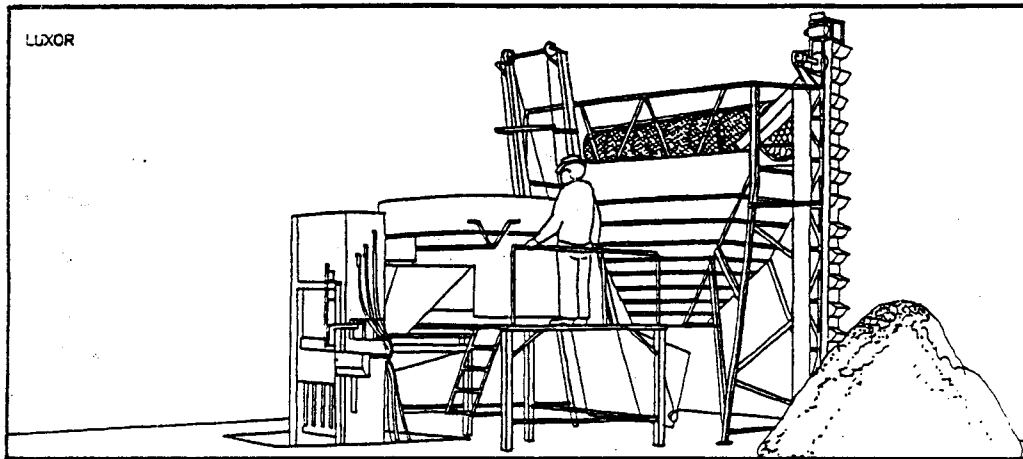

ROOF SYSTEM ADDITIONS

(THERE WILL BE ENERGY USE PENALTIES ASSOCIATED WITH COVERING THE FLAT ROOF HEATING AND COOLING SYSTEM BUILT INTO THE BUILDING SYSTEM)

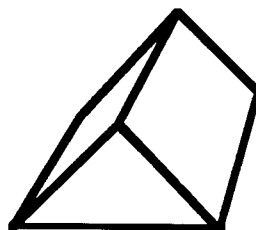
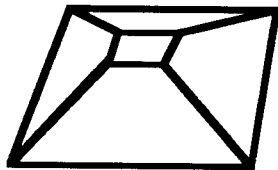
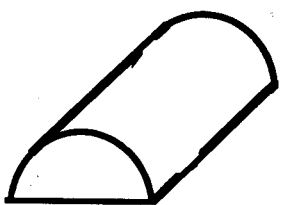

STUD MACHINE

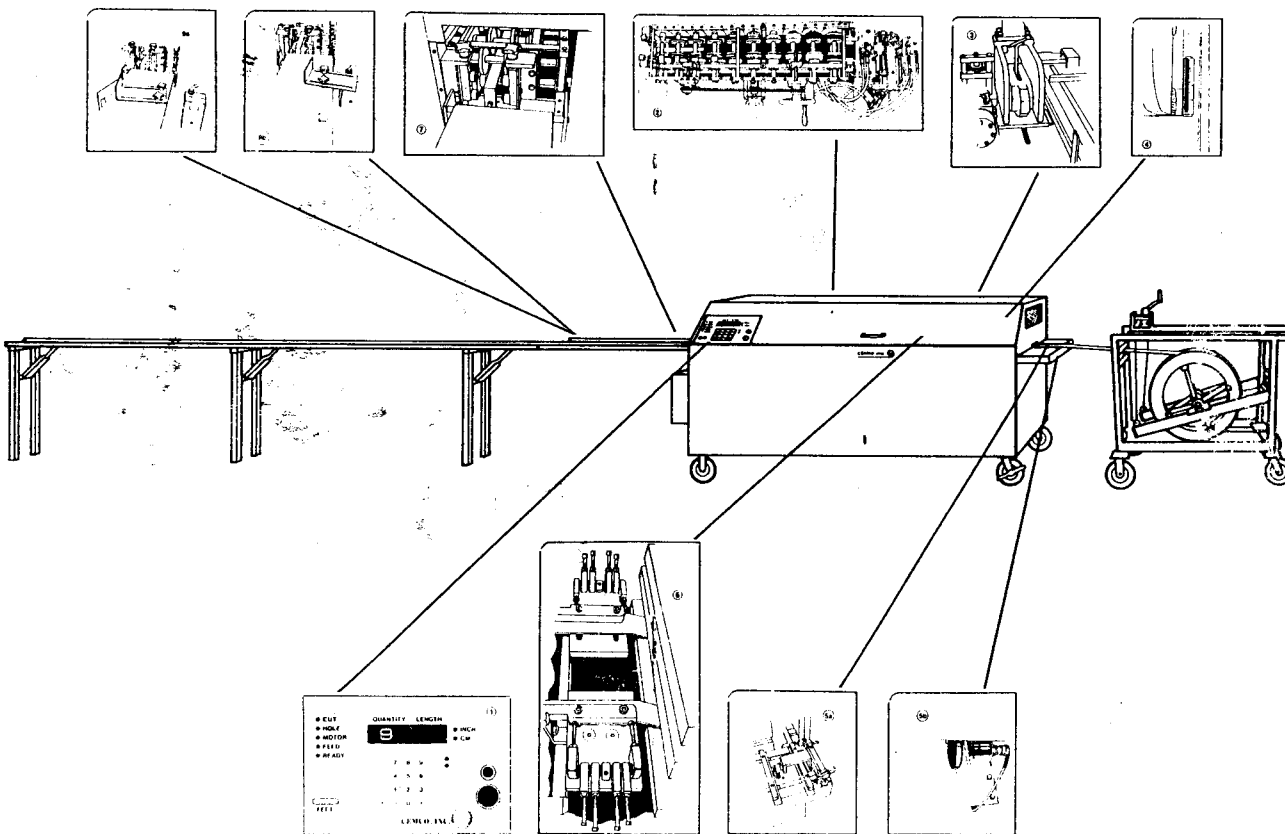



STEEL TRUSS & FRAME

STANDARD MEMBERS

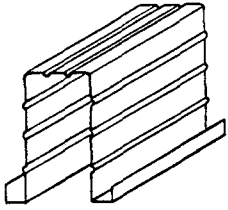

TOP CHORD
Pat. Pend

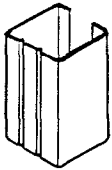

TRUSS WEBB
Pat. Pend

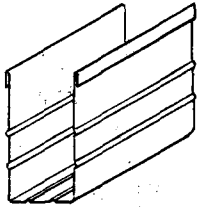

BOTTOM CHORD
Pat. Pend

- ★ Available in different sizes and gauges
- ★ Designed for
 - Roof trusses
 - Floor trusses
 - Mansard brackets
 - Re-roof over existing materials
- ★ Lightweight strength
 - Patented reinforcing ribs
- ★ Easy to cut & screw
- ★ Galvanized for corrosion protection

STEEL TRUSS & FRAME

STANDARD TRUSSES



COMMON

- SPANS - 5' TO 70'
- PITCHES - 2:12 TO 12:12
- LOADING - 75PLF - 160PLF - 200PLF



FLAT TOP

- SPANS - 5' TO 60'
- PITCHES - 4:12 TO 12:12
- LOADING - 75PLF - 160PLF - 200PLF
- GIRDER LOADING FOR HIPS



SCISSOR

- SPANS - 5' TO 40'
- PITCHES TC 4:12 TO 12:12 (BC = 1/2 OF TC Pitch)
- LOADING - 75PLF - 160PLF - 200PLF

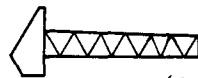

FLAT

(SHOWN WITH MANSARD)

- WITH OR WITHOUT MANSARD
- SPANS - 5' TO 40'
- DEPTH (MIN. L/20)
- LOADING - 75PLF - 160 PLF - 200PLF
- GIRDER LOADING AVAILABLE



MONO

- SPANS - 2' TO 25'
- PITCHES - 2:12 TO 12:12
- LOADING - 75PLF - 160PLF - 200PLF



MULTI-USE JOIST

- SPANS 4' TO 60'
- FLOOR JOISTS
- RE-ROOF SYSTEMS

- ALL TRUSSES AVAILABLE KNOCKED DOWN W/PREMARKED MEMBERS
- MAX PREFAB LENGTH 40' HEIGHT 10'-0"
- WEB CONFIG. VARIES ACCORDING TO SPAN & ENGINEERING REQUIREMENTS

ROOFING LINER

Our EPDM roofing system offers any builder or roofer the means to permanently waterproof flat roofs, rooftop decks, and earth-sheltered buildings. Installation is clean, simple, and fast—even in cold weather—and can be accomplished without heating torches or hazardous adhesives. Our system can outperform most other quality flat-roofing and waterproofing systems on the market, including metals, PVC plastics, and rubber-modified bitumens.

Our system is based upon a black, 60 mil sheet of cured EPDM (Ethylene Propylene Diene Monomer), a synthetic rubber known for its outstanding weathering properties. It will remain flexible throughout the coldest winters, it won't crack or dry out in the hottest summers, and it will withstand permanently ponded water. It is also fully UV stable and is unaffected by air pollution and acid rain, so no protection is required for fully exposed applications.

Although EPDM has been used successfully on large commercial buildings for more than twenty years, commercial EPDM systems offer many pitfalls and hazards to the inexperienced installer. Failure to master the techniques for cleaning, applying seaming and bonding adhesives, and working with flashing materials can shorten the life of the roof and lead to premature seam failure.

We eliminate most installation problems by pre-fabricating many of the seams and flashings that would normally be done in the field. Where field seaming is unavoidable, our talc-free sheet requires only minimal cleaning and our seaming tapes assure reliable results. The result is a system so simple that the first-time user can obtain a perfect job.

We custom-fabricate a sheet of rubber to the size required for each roof so there is little waste. If the roof is to be fully exposed to the elements, we will supply our unique *Flap Sheet*, a sheet of rubber with long flaps running the length of the underside. Starting at the center flap and working toward the edges of the roof, these flaps are fastened to the roof with screws and anchor plates. This way none of the screws pierces the surface and no patching is required. Our attractive, durable termination bars are used to secure the perimeter.

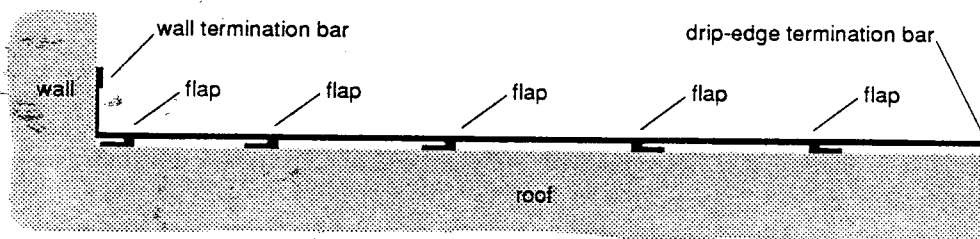









If the roof is to be covered with a wood deck, gravel, earth, or other heavy materials that will prevent the rubber from blowing away, we can supply our less-expensive *Deck Sheet*. This is also custom fabricated, but it has no flaps on the underside. The sheet can be simply spread out over the roof and mechanically secured at the perimeter with our termination bars.

RESOURCE CONSERVATION TECHNOLOGY, INC.

2633 North Calvert Street Baltimore, MD 21218 (301) 366-1146

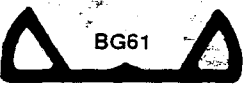
BUILDING GASKET SPECIFICATIONS

ACTUAL SIZE* ILLUSTRATION	DESCRIPTION AND APPLICATIONS	UNIT** LENGTH	STOCK NUMBER
BG20 	These gaskets are ideal for sealing drywall to studs and plates. Both compress easily to less than 1/8" and do not cause noticeable bowing in the drywall. BG20 has an adhesive backing and works for either wood or metal studs. It can also be adhered to rigid foam boards used as interior sheathing. BG32 is designed for attachment to wood only and features a wide stapling flange for easy installation in any weather, even when the lumber is wet or dirty.	328 ft 1 ft	BG20.10 BG20.11
BG32 			
BG34 	"P" gaskets solve a variety of structural and non-structural sealing problems. All feature wide stapling flanges for easy installation in any weather, even when the lumber is wet or dirty. The hollow center assures effortless compression over a wide range of movement. Applications include joints in log and heavy timber construction, joints between manufactured wall or roof panels such as stress-skin panels, and joints between sections of manufactured homes ("marriage walls"). Small P gaskets can also be used to make inexpensive yet reliable seals around attic access doors. We stock three sizes: BG34 for gaps up to 3/8", BG36 for gaps up to 5/8", and BG38 for gaps up to 7/8". Larger sizes are available on special order.	328 ft 1 ft	BG34.10 BG34.11
BG36 			
BG38 			
BG44 	These gaskets are designed to seal gaps, such as those between window or door jambs and the rough framing. They are as effective as spray foams, yet are much more durable and safer and work in any weather. When polyethylene is used, the gaskets anchor and seal the edges. We offer two sizes: BG44 for gaps 1/4" to 1/2" and BG46 for gaps 3/8" to 3/4". Frame window openings 3/4" wider and taller than the window frame to assure gaps within these ranges. Avoid creating very tight gaps: they are difficult to seal by any means and can cause the windows to bind.	164 ft 1 ft	BG44.10 BG44.11
BG46 			
BG61 	These gaskets are designed for structural sealing under heavy loads. Typical applications are seals under sill plates, wall plates, wall or roof panels and other load-bearing joints. Choosing a seal the width of the plate will eliminate the need for additional dampproofing between wood and masonry or concrete foundations. We stock three sizes: BG61 for edges of "2 by" lumber, BG63 for 2 x 4's, and BG65 for 2 x 6's. BG61 is also used to gasket exterior foam sheathing or stress-skin panels to wall framing.	164 ft 1 ft	BG61.10 BG61.11
BG63 			
BG65 			

EXTERIOR INSULATION

INSULATION BOARD

DRYVIT® Insulation Board meets requirements of Federal Specification HH-1-524C, Type 1.

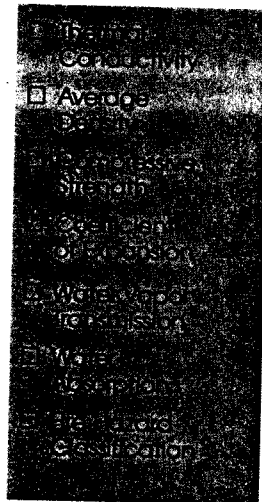

- ASTM C-177
- ASTM D-1622
- ASTM D-1621
- ASTM D-696
- ASTM C-355
- ASTM C-272
- ASTM E-84

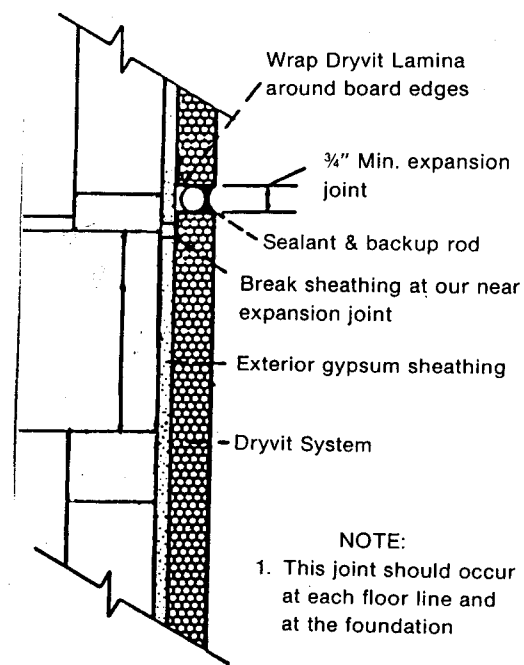
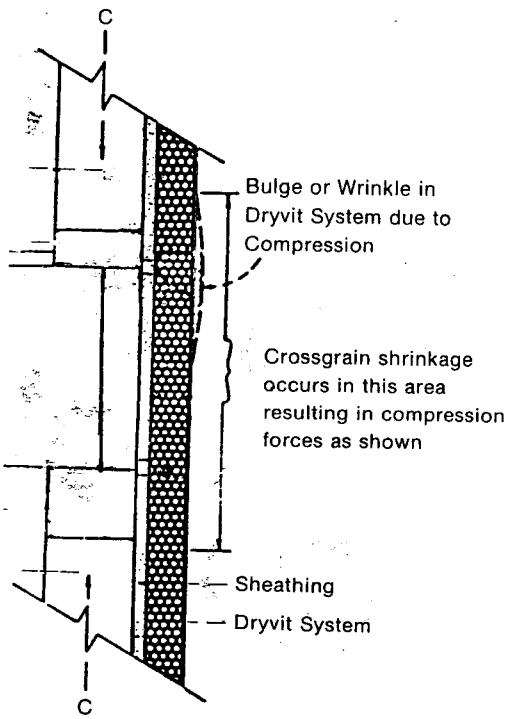
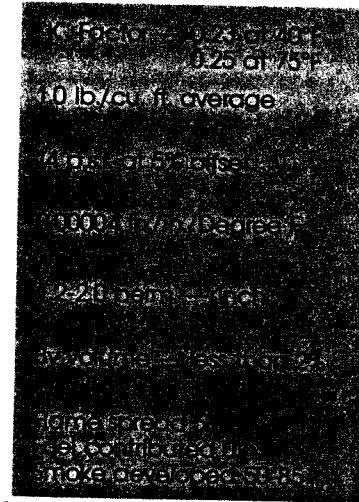

NOTE:
1. This joint should occur at each floor line and at the foundation

CONCRETE IMITATION WOOD

WOOD-LOOKING WALLS (psst—THEY'RE CONCRETE)

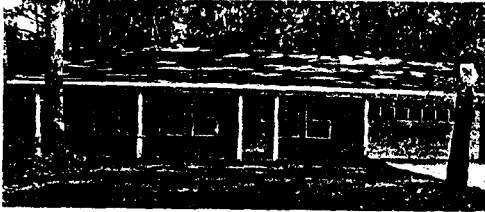

More than 80 homeowners in the Indianapolis area are having it both ways: the appearance of a wood house coupled with the strength and fire resistance of concrete. Their houses have Walston Walls—named after designer Everett Walston—made of concrete panels precast in wood-textured molds. The 700-pound Walston walls consist of one-inch-thick fiber-reinforced concrete supported by steel-reinforced ribs, seven inches of polystyrene insulation inside the concrete, and furring strips for drywall installation. Some have precut and framed openings for doors or windows. They are manufactured in four-foot increments by Beaver Products (16101 River Ave., Noblesville, Ind. 46060).

One flatbed trailer delivers the whole house, and it takes only five or six hours to erect the walls. The panels are lifted with a crane by loops of cable embedded in the concrete, and braced until roof trusses are installed. Builders put an insulating rope between the panels to permit expansion and contraction, caulking the outside with urethane rubber to make the house airtight.

Walston Walls can be painted with latex, stained, or left natural. The concrete panels are sound deadening and provide thermal mass to reduce heating and cooling expenses. Their insulation rating is R-35, about 24 points higher than that of a conventional frame house with 2 x 4 stud walls. A finished Walston Wall house costs between \$34 and \$40 per square foot.—D. S.

FLEXIBLE WALLS



Movable walls held by spring-loaded supports, snap-on wiring channels, and clever plumbing runs add up to

Tenants of this apartment in Sweden can design the interior themselves—and easily change it later. The structure is made of precast concrete panels lifted by a crane and bolted and cemented together. Cladding panels consist of wood siding and insulation, with windows and doors factory installed (far left).

The tops of the interior walls have drilled sockets that hold heavy-duty spring supports (left). The T-shaped tops of the supports fit into grooves in a wooden channel (also movable) that is temporarily held in place by a spring-loaded telescoping pole when a wall is being moved. To move a wall panel, the tongue of a special dolly is slipped under the bottom (lower left). As the operator pushes down and pulls forward on the dolly handle, the wall section tilts; a helper must support it. Then the dolly operator and helper can move the panel to its new location.

The electrical wiring goes through channels

that snap over the tops of the walls. The conductors connect with vertical wiring runs to feed the switches and outlets (drawing bottom); the photo at bottom shows the finished interior.

Floor plans show how a family might alter an apartment as its needs change: A young, childless couple could choose a large living room, dining room, and kitchen (left). Here, the master bedroom opens into a bath with a sauna. When a child arrives (center), a bedroom, bath, and closet are created, mostly from the living room. The master bath loses its sauna to make space for a hall. After the child leaves home, an elderly parent moves in (right). The child's room is enlarged (further reducing the size of the living room), and a kitchenette is added. A new entry serves that suite, and the former entry is moved. Later in life, an elderly widow might remain; if she wanted less space and less expense, her apartment could be reduced in size and a neighbor's increased (not shown).

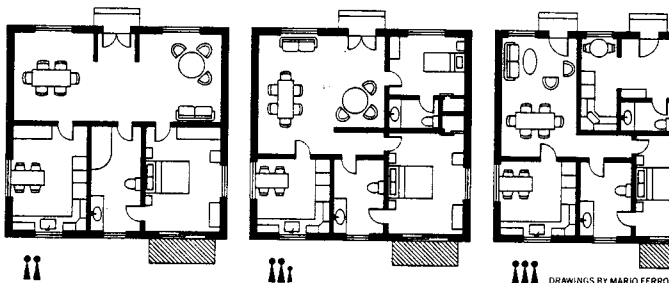

DRAWINGS BY MARIO FERRO

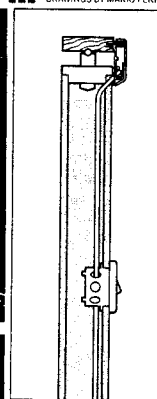

A HOUSE FOR ALL SEASONS

By FRANK LUSK

MROSBURG, SWEDEN Most households are dynamic—they grow with marriage and family, shrink as the kids grow up, and perhaps grow again when a child comes back temporarily or an elderly relative moves in.

To accommodate the seasons of our lives, we often must add rooms to our houses, rip out and remodel—or pack up and move. The cost is considerable, in both dollars and disruption.

Now a Swedish company, Skarne Systems Development, has come up with a building system that makes it easy to reconfigure a house. Allan Skarne, an energetic and progressive 80 year old, gets credit for the ingenious system, which starts with sturdy yet movable interior walls. A prototype eight-unit apartment building, which Skarne calls the Dynamic House, was recently completed in this suburb north of Stockholm. The technology also can be used in single-family houses and small commercial buildings, the company notes.

"The cost of renovating a building can exceed the cost of putting up a new one," declared Stig Hörling, a Skarne representative, as he showed me around the prototype project. "We wanted to design housing that would suit all people and economically

accommodate whatever needs may arise in the future," Hörling explained. All interior walls are non-loadbearing. The movable wall panels have wood frames and mineral-wool insulation, and are covered with Sheetrock. They are 2.5 meters in height (about eight feet), seven centimeters (2¾ inches) thick, and are made in four widths: 0.3, 0.6, 0.9, and 1.2 meters (approximately one, two, three, and four feet). Their weights range from 25 to 80 kilograms (55 to 176

PHOTOS BY THE AUTHOR

accommodate whatever needs may arise in the future," Hörling explained. All interior walls are non-loadbearing. The movable wall panels have wood frames and mineral-wool insulation, and are covered with Sheetrock. They are 2.5 meters in height (about eight feet), seven centimeters (2¾ inches) thick, and are made in four widths: 0.3, 0.6, 0.9, and 1.2 meters (approximately one, two, three, and four feet). Their weights range from 25 to 80 kilograms (55 to 176

re-routed without a license," he added.

Vertical plumbing runs are confined to exterior walls, and horizontal pipes are laid in the hollow cores of the cast-concrete floor slabs. For access to the plumbing, a hole must be cut in the floor (not a job for the uninitiated, but the apartment superintendent can do it). When a hookup is no longer needed, it can be capped. Only cold water is delivered to the apartments; point-of-use water heaters provide the hot water. The bathrooms are modu-

lar, and all the fixtures hang on the walls, which means that even a bath can be added or moved with relative ease. (The suspended bath fixtures also offer silent testimony to the strength of the mobile wall panels.)

Satisfied with the prototype apartment, Skarne Systems Development is moving ahead with plans to build a 27-unit complex not far from this one. Additional projects are planned for Norway, France, and possibly the United States. □

pounds). Doors are factory installed.

The panels are held in place by the compressive force of two spring elements mating with a notched wooden guide strip against the ceiling. Rubber strips at the top and bottom prevent any slippage. Plastic tubing placed between the notched edges of the wall panels seals the joints. Walls separating apartments are built in much the same way, but are twice as thick and nearly soundproof.

One of the apartments in the Dy-

OWNER OR LABOR BUILT STAIR SYSTEM

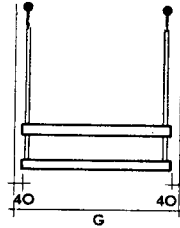
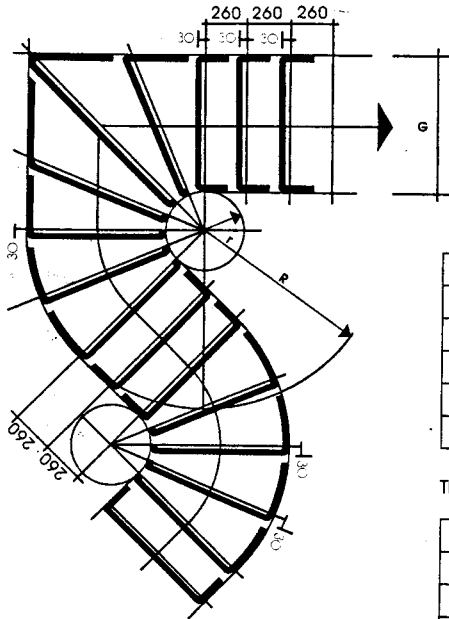

G	R	r	A	B	A+B
28 6/16"	40"	11 1/16"	41 1/8"	38 7/8"	80"
32 5/16"	42"	9 5/8"	43"	41"	84"
36 1/4"	44"	7 1/16"	45"	43"	88"
40 3/16"	45 7/8"	5 3/4"	47 1/16"	44 11/16"	91 6/8"
44 1/16"	47 7/8"	3 3/4"	49"	46 6/8"	95 6/8"

This table provides a check on the overall dimensions of the stairs and handrail.

G	R	r	C	D	C+D
32 5/16"	29 1/2"	0	30 11/16"	28 7/16"	59"
36 1/4"	33 15/32"	0	34 5/8"	32 5/16"	66 15/16"
40 3/16"	37 13/32"	0	38 9/16"	36 1/4"	74 13/16"

The drawing provides a guide for swift and accurate planning of a staircase using the AMIKA system. Lines in red indicate the structural geometry, and the effective position of the treads is shown in black. To ensure correct calculation of dimensions and clearances (see table), it must be remembered that:

- nominal depth of each tread is 10 1/4", except for the top step, which measures 12 5/8"
- riser height is adjustable from 6 11/16" ÷ 8 1/4"
- five tread widths are available: 25 3/16", 29 1/8", 33 1/16", 37", 41", standard depth 12 5/8"
- the overall width of the staircase is calculated by adding 1 9/16" to each side of the tread (i.e. standard width + 3 3/16").

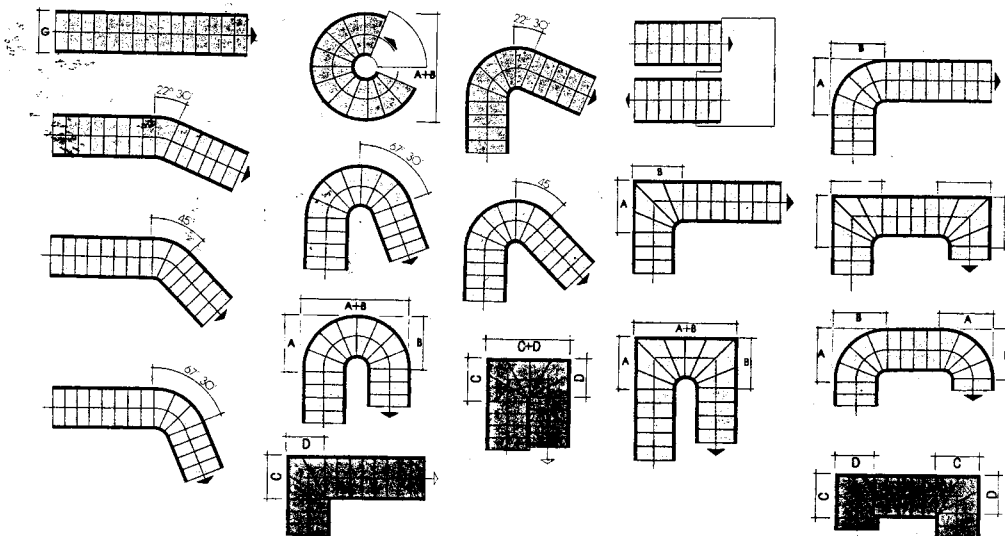

VARIABLE SHADE SYSTEMS

heated above room temperature, turns an opaque white that reflects the entire spectrum of sunlight, and then turns clear again when cooled. The transition temperature can be tuned during manufacture to create a variety of indoor climates for people and plants. The figure shows the total solar transmission versus temperature characteristics of Cloud Gel. The transmission drops from 92% to 30% when the Cloud Gel is heated only 3°F.

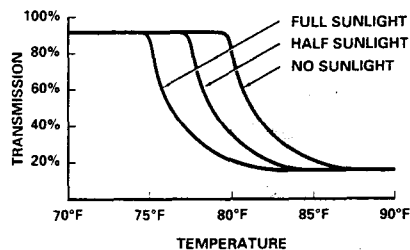

Cloud Gel Performance

WEATHER PANEL

The transformation of passive space conditioning from a design art and science to a small family of profitable and easy to use products is a vital link to reducing world energy consumption. Manufactured products mobilize the very effective and massive resources of existing building materials manufacturing and distribution organizations. These corporations have the contractor's ear; economically effective products give them a reason to educate contractors, as DOE and academia have been unable to do.

How can low emissivity coatings and optical shutters be turned into building products? These molecularly designed building materials are not usable by building contractors in the form of plastic films. By combining them with a weather skin and structural system and thereby producing manufactured modules, on site labor is minimized. While flexible plastic films are the minimal materials with which buildings are made, the people who use and who make buildings are accustomed to rigid structures, so integration into existing ways of thinking favors incorporation of the low emissivity coatings and Cloud Gel into rigid modules easily digested by contractors.

The figure shown is a 4 by 8 foot building panel called the Weather Panel which incorporates a transparent insulation and optical shutter. This design has a thermal resistance of 9 and a solar energy transmission which varies between 60% and 7%, depending on the indoor temperature. Anti-reflection coatings on all the surfaces (except the low emissivity coating, which is already anti-reflected) boost the solar transmission to 75 - 80% when cool and 9% when warm. These units will be available from the KalWall Corporation, the nation's leading manufacturer of translucent building panels. They will cost approximately \$20 per square foot when production volumes become large, the same cost as a finished wall or roof which does not capture heat or light.

SKYLIGHTS

For skylights, the internal configuration is usually the same as the Weather Panel. Since skylights are usually used as a source illumination rather than heat, they are made from the type of Cloud Gel which is activated by incident sunlight, rather than indoor temperature. Wasco, the nation's leading plastic skylight manufacturer, plans to put these smart or homeostatic skylights (called Lumistats) on the market soon. When manufacturing volumes become large, costs will be approximately \$20 per square foot.

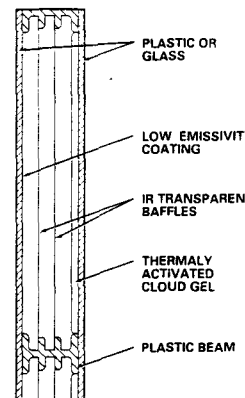
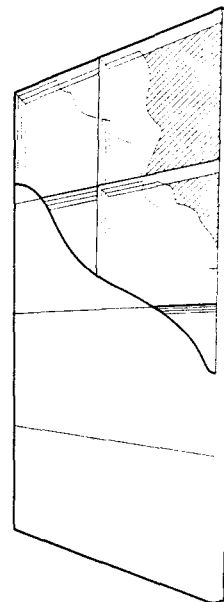

Weather Panel

MO HO MOT-R®

The MO HO MOT-R from Sol-R-Veil, Inc. is a high quality tubular motor that is made to handle the toughest demand wherever MOT-R-TUBES can be used.

MO HO MOT-R's are high torque, low noise and low maintenance. The gears are sealed for life. A recent independent test found the MO HO MOT-R to cycle through 240,000 up and down movements and was still running strong. 240,000 cycles equals 30 years of normal use.

Typical uses... Rollerscreens, both interior and exterior
Awnings
Window Quilts
Stage Draperies
Pool Covers
Roman Shades
Rolling Doors & Grills

MO HO MOT-R® SPECIFICATIONS

Different jobs demand different size motors. The following specifications will explain load & power limits for the various MO HO MOT-Rs.

MODEL	RPM	LOAD LBS.	SIZE OF MOT-R TUBE	*HEIGHT OF LIFT	TORQUE IN/LBS	AMPS	WEIGHT	RETAIL PRICE
Brusier	30	30	65 mm = 2 ⁹ / ₁₆ "	18.9'	44	1.1	5	457.60
Heavy-weight	16	98	65 mm	18.9'	175	2.2	6	550.00
Mauler	12	112	65 mm	18.9'	220	2.2	6	624.80
Sampson	12	221	76 mm = 3"	22.0'	435	3.5	11	814.00

Price includes MOT-R, brackets, 3-way switch, 10' cord, and plug.

*Please Note: for Exceptional Requirements Please Contact our Engineering Dept. for Information
Mo Ho Mot-Rs were used on shades at The Metropolitan Museum of Art, New York, N.Y. The windows were over 60' high

PRINCIPAL CHARACTERISTICS:

1. Capacitors are built-in making wiring easier (3 wires & ground).
2. Protected by a thermal cutout (rated at 140°C).
3. Powerful disc brake provides instantaneous stops without slipping.
4. Easily adjusted limit switch permits 30 rotations of the roller tube. (U.S. Patent No. 3,718,215)
5. Running time, 5 minutes.
6. Packing: Individual polystyrene box shipped in standard cartons of 10. Master carton weight is 68 Lbs.

The limit switches are easily adjusted by turning either of the two thumbscrews numbered 1 or 2 as indicated in the diagrams

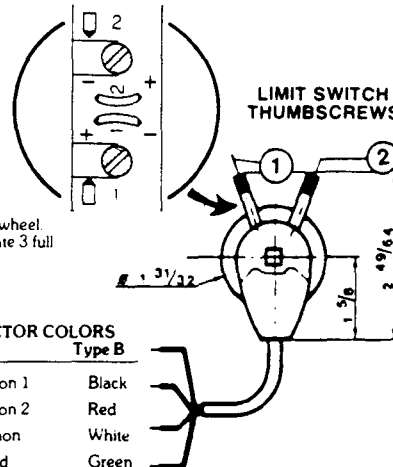

NOTE:—Seven (7) turns of the thumbscrew equals one (1) full turn of the motor drive wheel.
—The limit switch has been pre-set at the factory to allow the drive wheel to rotate 3 full turns in each direction
—The drive wheel can turn 27 turns (Maximum) in either direction

HOW TO ADJUST THE LIMIT SWITCHES:

	MOTOR ON THE LEFT HAND SIDE	MOTOR ON THE RIGHT HAND SIDE
INSIDE ROLLING	<p>The thumbcrew NO 1 regulates the bottom stop position and the thumbcrew NO 2 regulates the top stop position.</p>	<p>The thumbcrew NO 1 regulates the top stop position and the thumbcrew NO 2 regulates the bottom stop position.</p>
OUTSIDE ROLLING	<p>The thumbcrew NO 1 regulates the top stop position and the thumbcrew NO 2 regulates the bottom stop position.</p>	<p>The thumbcrew NO 1 regulates the bottom stop position and the thumbcrew NO 2 regulates the top stop position.</p>

SOL-R-VEIL INC

635 West 23rd Street
New York, N.Y. 10011
(212) 924-7200

MULTI-LAYER RADIANT BARRIER

Reflectix Insulation

Reflectix is a wonderful new insulating material with dozens of other ancillary uses, that is lightweight, clean, and requires no gloves, respirators, or protective clothing for installation. It is a 5/16" thick reflective insulation which comes in rolls and is made up of seven layers. Two outer layers of aluminum foil reflect most of the heat which hits them. Each layer of foil is bonded to a layer of tough polyethylene for strength. Two inner layers of bubblepack resist heat flow, while a center layer of polyethylene gives Reflectix additional strength.

Reflectix can be used wherever standard fiberglass insulation is used, without the necessity of wearing goggles or a face mask for installation. It has an R-value comparable to standard insulation (see chart). Reflectix inhibits or eliminates moisture condensation while providing no nesting qualities for birds, rodents, or insects. Other benefits include reductions in heating and cooling costs that accelerates the payback time of the cost of installation over ordinary insulations. It is Class A Class 1 Fire Rated and non-toxic.

Reflectix comes in several configurations: Reflectix BP (bubble pack) is installed to the exterior of a wood-frame structure prior to installation of the siding, stapled to the studs. BP is also used in retrofit installations. It is also installed as the outside layer when HR is installed between the studs in ceilings, attic floors, basements, and interior walls. Reflectix HR (high R-value) insulation is for new construction or where a greater R-factor is desired. It comes with built-in staple tabs so that it can be installed between studs and ceiling joists much the same as old-fashioned insulation.

Tape for Reflectix

Reflectix makes an aluminum tape that is excellent for bonding two courses of Reflectix together. It works far better than masking tape or duct tape. It also has reflectability and is highly recommended for any Reflectix installation. Two sizes of tape rolls are available: 30' x 2" and 150' x 2".

30' Roll of 2" Reflectix Tape **\$2.65**
Ship wt. 1#

150' Roll of 2" Reflectix Tape **\$9.45**
Ship wt. 3#

R-Value Table for Reflectix

Reflectix Type	Up	Down	Horizontal
Reflectix BP	8.3	14.3	9.8
Reflectix HR	11.5	20.3	11

As well as its most common usage as a building insulator, Reflectix has a myriad of other uses: Pipe wrap, hot water heater wrap, duct wrap, window coverings, garage doors, as a camping blanket or beach blanket, cooler liner, windshield cover, stadium heating pad, camper shell insulation, behind refrigerator coils, and a camera bag liner.

Reflectix BP (Bubble Pack) comes in 16", 24" & 48" widths and in lengths of 50', 125' & 250'. (We cannot UPS rolls larger than 125".)

Reflectix HR (High R-Value) is designed for use with 16" and 24" on center construction and comes in 16" and 24" widths. The 16" widths are sold only in multiples of 500 square feet, and the 24" widths are sold only in multiples of 700 square feet.

We believe in Reflectix and are introducing it at a very attractive price!

Reflectix insulation **\$0.39 per square foot**
(Specify roll width, size, and HR or BP)

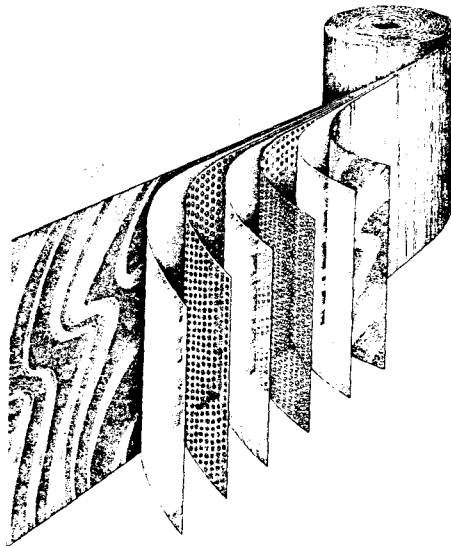

HEATING - COOLING - DAYLIGHTING - PHOTOVOLTAIC SYSTEM

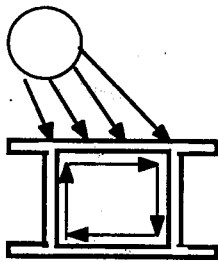

DAY - NIGHT SOLAR HEATING

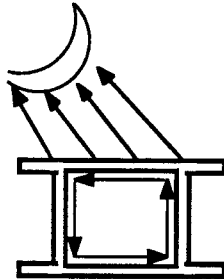

DAY - NIGHT SOLAR COOLING

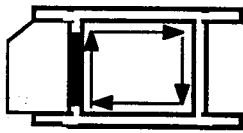

SOLAR SUN SPACE GREENHOUSE

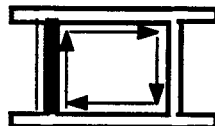

TROMB WALL

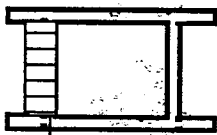

HEAT PUMP HEATING - COOLING - HOT WATER BACKUP

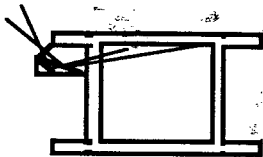

INDIRECT DAYLIGHTING

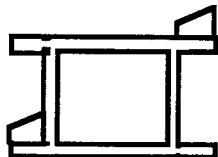

SOLAR HOT WATER - SOLAR DISTILLATION - PHOTOVOLTAICS

BUILDING COMPONENTS

BC

SPACE HEATING AND COOLING SYSTEM USING DAYTIME SOLAR INPUT DURING WINTER AND NIGHT TIME RERADIATION DURING SUMMER

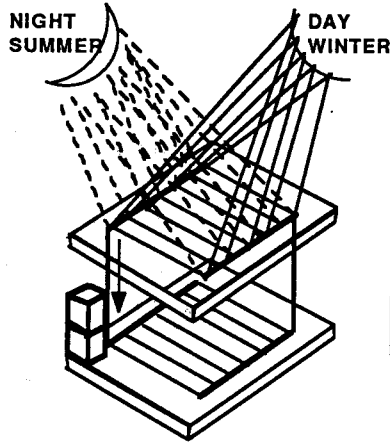

SYSTEM DURING BACKUP USE THUS SHORT CIRCUITING ROOF

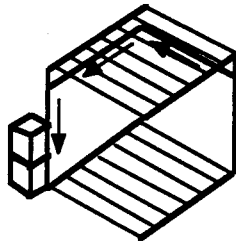

ROOF COLLECTOR / EMMITT VARIABLE INSULATING / CONDUCTIVE ROOF USING OPEN CELL FOAMED CONCRETE WATER DRAINED VERSES FLOODED

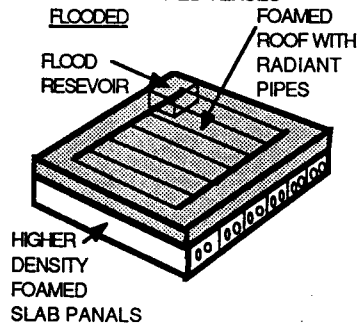

DOWN SIZED AUXILIARY GROUND SOURCE HEAT PUMP BACK UP FOR HEATING COOLING AND HOT WATER

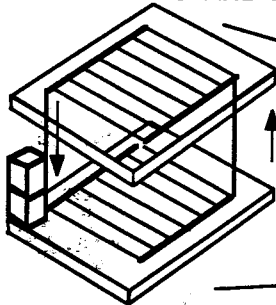

GROWTH AND FOR RELATIONSHIP

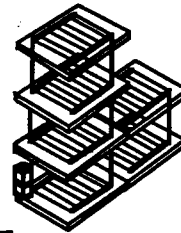

HEATING COOLING SYSTEM COINCIDENT WITH STRUCTURAL SYSTEM

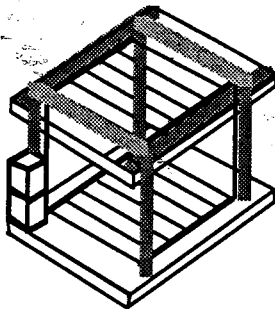

DAYLIGHTING

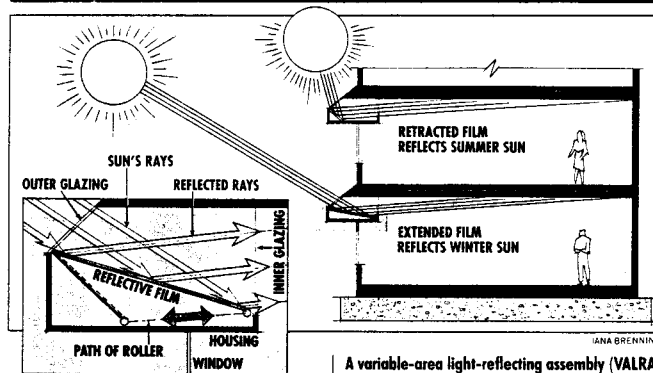
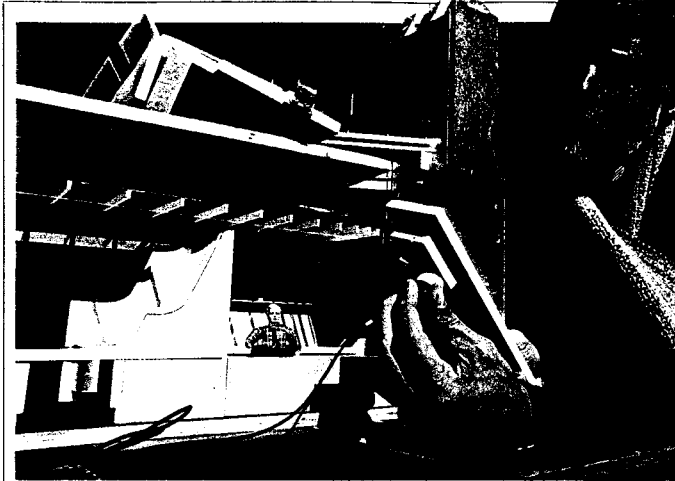

gineering and architectural company founded by Buckminster Fuller.

With the VALRA design, sunlight streaming into a special aperture strikes a silver-coated Mylar film, which reflects it, sending it through an inner glazing and deep into the room. The film's inner edge is attached to a roller. As the sun moves, daily and seasonally, the film's angle changes. Motor-driven computerized controls automate the film's movement.

Dr. Wayne Place, a well-known daylight researcher at North Carolina State University in Raleigh, has tested the VALRA and other daylighting systems extensively. Place and his colleagues first build model buildings, put light sensors in them, then attach them to a heliodon, a turntable they can steer to position the model at any angle relative to the sun. If a design proves effective, they then build a full-

A variable-area light-reflecting assembly (VALRA) uses a reflective film to bounce sunlight deep into a room (drawings). The film's position changes to match the sun's angle. Dr. Wayne Place of North Carolina State University (photo) installs light sensors in a model room to test VALRA's effectiveness.

scale mockup and place it in a full-size rotating test building.

Such tests have shown that a VALRA can direct sunlight up to 100 feet into a building at solar noon on a day with full sun. But because solar conditions vary, a more practical goal would be to count on daylight penetration to a depth of 40 feet, Place says. Model studies and computer simulations show that a VALRA system could reduce electricity used for lighting by 71 percent in Phoenix and 44 percent in New York City. In fact, the dollars saved would be greater in New York because of its higher kilowatt-hour rate.

Sunlight is intermittent, though, so a backup conventional lighting system must be installed. That's a big expense.

HEAT EXCHANGER

"ALTERNATING-CURRENT" HEAT EXCHANGER CLEANS AIR TOO

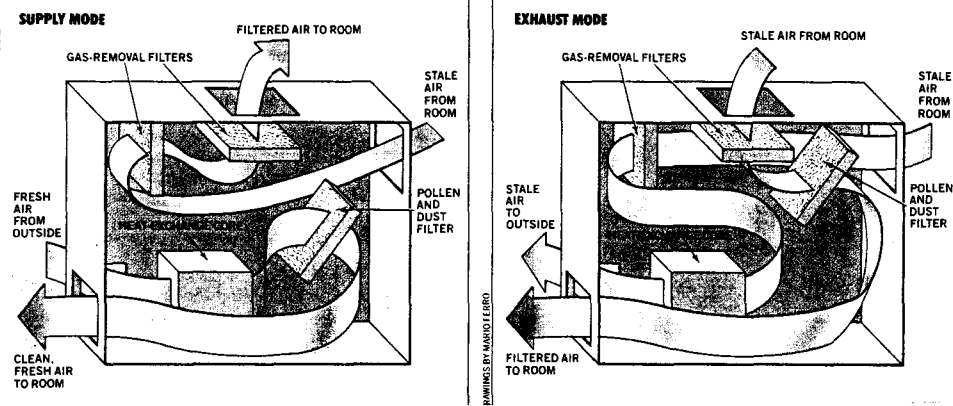

Berner's new AQ Plus heat exchanger alternates between supply and exhaust modes every three seconds. In the supply mode (left), it brings in fresh air from outside, routing it through the heat-exchange core (where it picks up heat in winter and loses heat in summer), then through a pollen and dust filter and out into the room. In the exhaust

mode (right), stale room air is routed through a gas-removal filter, then through the heat-exchange core (to lose or gain heat). Finally, it is vented outside. In both modes some room air is circulated through a series of filters and returned—cleaned—to the room. (Two fans, not shown in the cutaways, drive the airstreams.)

duce the R-value of the wall as a whole. For example, a five-percent void in R-11 batt insulation installed in a 2x4 stud wall can drop the wall's total R-value to as low as 6.47.

Although Ark-Seal hasn't announced the R-values of Fiberiffic yet, Adams says the numbers should rival that of Blow-in-Blanket, which is approximately R-23 for a 2x6 cavity. "Fiberiffic may have an even higher R-value," says Adams, "but it would be jumping the gun to say more at this time."

A late spring 1990 introduction is planned, according to Adams. Fiberiffic will be available nationwide from selected Ark-Seal dealers.—J. A. Y.

Heat-exchanger redesign

Air-to-air heat exchangers (also called heat-recovery ventilators) are often a good solution to the humidity, stale air, and pollution problems that plague some energy-efficient houses ("Give Your House a Breather," Oct. '88).

Typically these devices use a supply fan to bring in fresh air from outdoors and an exhaust fan to remove stale air. Both streams are channeled through a heat-exchange core, where they travel a serpentine path on either side of a heat-conducting material. In winter, incoming fresh air is prewarmed by outgoing stale air;

in summer, incoming fresh air is precooled.

Now, Berner Air Products of New-castle, Pa., has introduced the Berner AQ Plus—a very different heat exchanger. Rather than running concurrent supply and exhaust streams, this machine runs first one then the other, alternating between the modes every three seconds. Both airstreams are sent through the same spaces in the aluminum heat-exchange core.

What's the advantage? Improved heat-recovery efficiency, explains sales manager Marilyn Myers. The company claims that 93 percent of the heat is recovered when the fan is running on low speed (60 cubic feet per minute). At medium speed (113 cfm), efficiency is given as 87 percent, and on high speed (165 cfm), it's said to be 82 percent.

Another unusual feature of the AQ Plus is its filters. Stale air from the room passes through a gas-removal filter before it enters the heat-exchange core. That keeps pollutants from being transferred along with the heat.

In addition, the AQ Plus continuously circulates room air, sending it through a dust and pollen filter and through a gas-removal filter before returning it to the room. The filter removes 66 to 95 percent of potentially harmful gases (formaldehyde, combustion byproducts, and vapors from

household chemicals), it's claimed. Dust and pollen removal (one-to-five-micron size) is said to be 60 percent.

One AQ Plus unit can clean and freshen the air in a 2,000-square-foot house, according to the company. The price tag is \$599, without installation. "But if you can install a dryer vent, you can install this heat exchanger," Myers comments.

Recycling polystyrene

Seven manufacturers of polystyrene—Amoco Chemical Co., Arco Chemical Co., The Dow Chemical Co., Fina Oil and Chemical Co., Huntsman Chemical Corp., Mobil Chemical Co., and Polystar Inc. Plastics—are participating in a massive recycling program. The \$14-million program has resulted in the formation of the National Polystyrene Recycling Co. (NPRC). The goal: to recycle 25 percent of all disposable household and commercial polystyrene products nationwide by 1995. This, according to Dow, is more than the current rate of either paper or glass recycling. To achieve that level of performance, five regional reprocessing facilities will be established during the next year.

The recycling process for polystyrene involves breaking down materials like foam cups and plates, packaging, plastic food utensils, and clear plastic food containers into small

RADIANT FLOOR SYSTEM

How much area will one zone control heat?

It varies anywhere from 250 square feet to 1,500 square feet. The amount of heat loss, the type of floor coverings and the tube spacing all influence the size of the area.

How is Infloor installed on suspended floors and over concrete slabs?

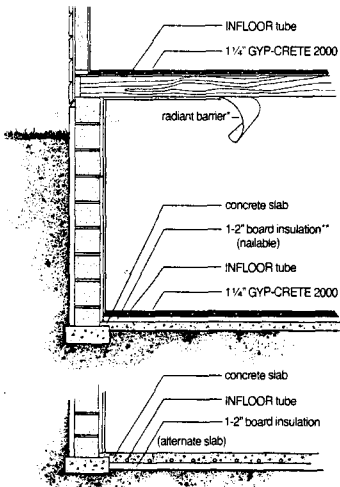

*The radiant barrier is used when downward heat loss is not desirable.
**Use a board insulation which has an onboard or plywood skin for nailing.
NOTE: Gyp-Crete 2000 is not to be installed on or below grade, except when the subsoils drain well.

What are the specifications of the zone control?

Pump: 115 VAC, 1.0 amp, 1/25 h.p.
Normal Output: 90°F to 140°F.
Maximum Fluid Temperature: 180°F.
Control Circuit: 24VAC.
Maximum Operating Pressure: 30 psi.

What are the specifications for the tubing?

Tubing: Polybutylene thermoplastic made to ASTM D 3309.
Design Rating: 100 psi at 180°F.
Dimensions: 3/8-inch inside diameter, 1/2-inch outside diameter.
Lengths: 200 feet maximum.

What are the specifications for Gyp-Crete 2000 Infloor Blend?

Function: Interior underlayment, not a wearing surface.
Compressive Strength: Up to 2,500 psi (modified ASTM C472).
Static Loading: Up to 3,000 psi.
'k' Factor: 5.44 BTU/sq. ft./hour/°F/inch thickness.
Specific Heat: .236 BTU/lb. -°F @ 85°F.
Weight: At 1 1/4", less than 12 lbs./sq. ft.
Dry Density: Typical density is 115 lbs./cu. ft.
Minimum Depth: 1 1/4 inches.

Will the type of floor coverings affect the output of the heating system?

Definitely. Floor coverings are a major factor when designing a radiant floor heating system. For example, a floor covered with ceramic tile or wood flooring can put out three times the BTUs of a floor covered with a heavy carpet and pad. That's why the flexibility of Infloor Heating Systems is so important.

What are the details of the Infloor warranty?

From the date of installation, there is a 25-year manufacturer's limited replacement warranty on the tubes, including an allowance for labor. The mechanical and electrical parts are covered under a 1-year limited warranty.

What might a simple system look like?

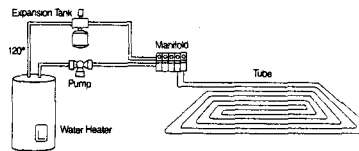

How can Infloor be used with a conventional system?

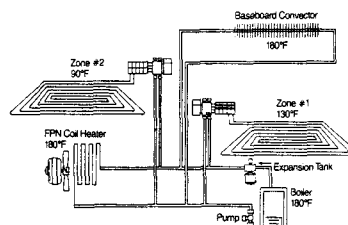

INFLOOR HEATING SYSTEMS

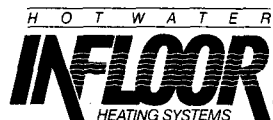

Capacity for supplemental heat
Even though floor temperature is set by this knob, hotter water is still available for supplemental heating.

Automatic air venting
A valve automatically vents built-up air.

Durable pump
Infloor's water-lubricated pump never needs oiling. And the stainless steel impeller won't get rust or corrode.

Precise temperature control
A four-way mixing valve between the primary and secondary loops maintains the desired floor temperature.

Digital display
Solid state circuitry helps detect problems. And parts replacement is quicker, due to Infloor's modular component design.

Easy connections
The 1/2-inch polybutylene tubing uses a unique "mounting" that slips into place, looks tight and won't leak.

Tough tubing
This polybutylene tubing won't corrode or electrolyze. It resists scale build-up and is freeze tolerant.

Brass fittings
These 1/2-inch brass fittings tighten down by hand and use an O-ring seal for no leaks.

Modular design
The manifolds are assembled to the correct length right on the job site.

Individual room controls
Use the manually adjusted balancing valves to supply more or less heat to a given room.

Versatile — Boilers, heat pumps, solar collectors, water heaters... Infloor works with any heat source that can deliver water at less than 180°F.

ENTRY KITCHEN BATH DINING DINING LIVING LIVING

DOWN DRAFT COOLING TOWERS

Sidewalk cooler

Air pollution and exposed concrete have raised the temperature of downtown Phoenix by 8 to 10 degrees F over the last 40 years. One oasis beckons: a city plaza planted with cool towers that drop air temperature 35 degrees and generate refreshing breezes.

By DAWN STOVER

Like the mythical bird it was named after, Phoenix, Ariz., built a nest in which to burn itself. Mountains surrounding the desert city trap heat-radiating automobile emissions, and vast paved areas soak up the sun's rays. The surface temperature of concrete sometimes exceeds 140 degrees F. It's so hot that a local weatherman recently showed television viewers how to fry eggs on a downtown sidewalk.

But last summer an oasis sprang up amid all this heat. Lush vegetation, fish ponds, and arching fountains replaced the exposed concrete of a downtown civic plaza. Two cool towers also appeared on the Solar Oasis, a project sponsored by the Environmental Research Laboratory of the University of Arizona, the city, and the state. One tower blew cool air into a trailer that housed exhibits on solar power, urban food-production techniques, and fish farming. Another provided outdoor air conditioning.

The design is based on centuries-old wind towers used in the Middle East. In the top of the tower a pump circulates water to evaporative pads made of corrugated cellulose (see drawings). Hot dry air passing through the pads is moistened and cooled. As it becomes heavier, it falls. The towers can cool the air by as much as 35 degrees F. "When you're walking across a parking lot that's more than 120 degrees, and you enter an area that's ninety degrees, it feels cool," says project engineer Kathy J. Kent. The towers also help clean the air, as do the plants.

The Solar Oasis used several other cooling methods, including an outdoor misting system. "The water shoots out of tiny nozzles," explains Kent, "and it evaporates before it falls to the ground." The project featured solar-powered lights and fans, plus "leaping" fountains producing a smoothly concentrated flow to minimize evaporation.

The demonstration project was dismantled last year as scheduled, but a larger Solar Oasis is being designed for the plaza (see photo) and should be completed in early 1990. Like the phoenix rising from its ashes to begin a new life, an entire city block will be transformed from a scorching slab to a cool oasis. "We can learn to live with the desert, using the resources available, without sacrificing our quality of life," says Kent. E

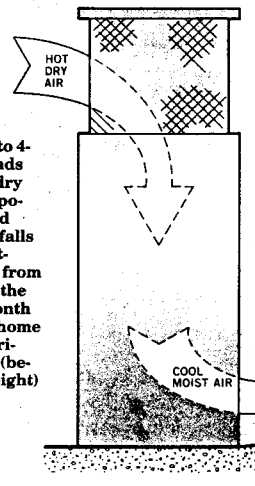
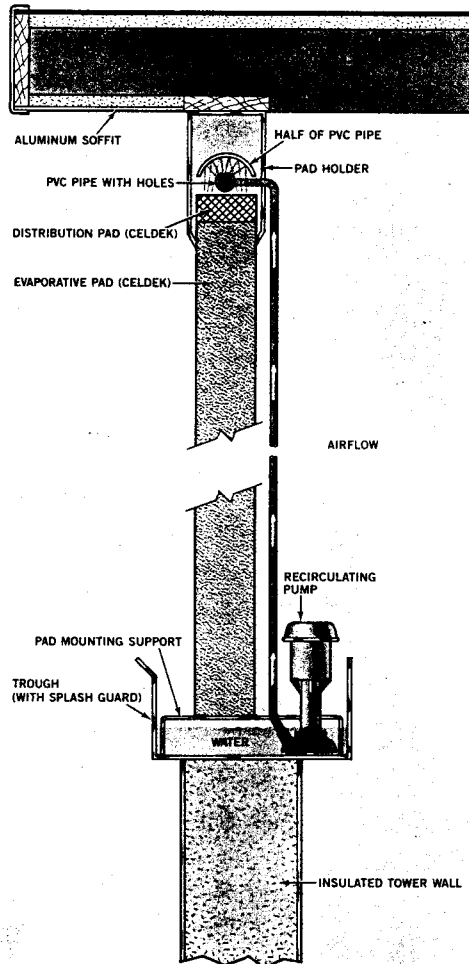

A 1/4-hp pump sends water to 4-in.-thick Celdek cellulose pads at the top of the tower. Hot dry air passing through the evaporative pads is moistened and cooled. The denser air then falls at 150-200 ft. per min., creating a cool breeze that blows from an opening at the bottom of the tower. It costs about \$5 a month to cool an average Phoenix home with this system. Design variables are the tower's height (because airflow varies with height) and cross-sectional area.

DRAWING BY MARIO FERRO

BUILDING COMPONENTS

BC

COOLING TOWERS

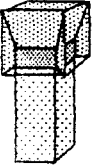
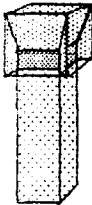
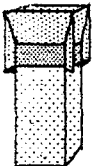
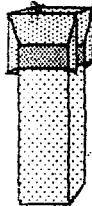
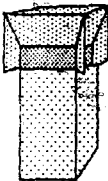
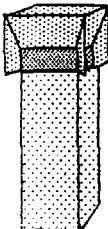
	PERFORMANCE (NO WIND)	MATERIALS	COST
 <p>CT-1 6 X 6 X 20</p>	<p>MAR -2250-4550 CFM APR -2250-4600 CFM MAY -2250-4775 CFM JUN -2200-4875 CFM JUL -2950-5100 CFM AUG -2950-5100 CFM SEP -2200-4500 CFM OCT -1950-4300 CFM</p>		
 <p>CT-2 6 X 6 X 24</p>	<p>MAR -2600-5300 CFM APR -2600-5400 CFM MAY -2600-5500 CFM JUN -2600-5600 CFM JUL -3400-5900 CFM AUG -3400-5900 CFM SEP -2600-5200 CFM OCT -2200-4900 CFM</p>		
 <p>CT-3 8 X 8 X 20</p>	<p>MAR -4200-8600 CFM APR -4200-8800 CFM MAY -4100-9000 CFM JUN -4200-9100 CFM JUL -5500-9600 CFM AUG -5500-9600 CFM SEP -4200-8500 CFM OCT -3900-8000 CFM</p>		
 <p>CT-4 8 X 8 X 24</p>	<p>MAR -4900-9900 CFM APR -4800-10,100 CFM MAY -4800-10,300 CFM JUN -4800-10,600 CFM JUL -6300-11,000 CFM AUG -6300-11,000 CFM SEP -4800-9800 CFM OCT -4200-9300 CFM</p>		
 <p>CT-5 10 X 10 X 20</p>	<p>MAR -6300-12,900 CFM APR -6300-13,100 CFM MAY -6300-13,400 CFM JUN -6200-13,700 CFM JUL -8200-14,300 CFM AUG -8200-14,300 CFM SEP -6200-12,700 CFM OCT -5400-12,000 CFM</p>		
 <p>CT-6 10 X 10 X 30</p>	<p>MAR -7300-14,800 CFM APR -7300-15,200 CFM MAY -7200-15,500 CFM JUN -7200-15,800 CFM JUL -9500-16,600 CFM AUG -9500-16,600 CFM SEP -7100-14,700 CFM OCT -6300-13,900 CFM</p>		

SOLAR POWERED EVAPORATIVE COOLER



New Breeze™ HOME COOLING SYSTEM

Everybody Can Afford It.

The New Breeze™ uses efficient space age technology brought down to earth. It runs on only a single 1' by 4' (weighs only 14 pounds) solar electric panel. And it uses only 2 to 4 gallons of water a day to cool and clean your air.

Now you can have clean, healthful air. Because the New Breeze™ purifies air from pollen and dust, it may be especially useful for people who suffer from allergies. Residues from cleansers, smoke, and household chemicals build up in your house. A standard air-conditioning system just recirculates this stale air. New Breeze™ filters out pollutants and brings in fresh air from outside.

A system built to last. The solar electric panel that runs your New Breeze™ will last up to 30 years. And the New Breeze's™ pump is revolutionary — efficient and long-lasting. The workings of the New Breeze™ is protected from the environment by a sturdy metal container.

It's easy to use. Just turn on New Breeze™ when summer comes — and leave it on. The solar panel acts as a "smart thermostat," adjusting to changing weather. *When the sun is at its hottest, New Breeze™ works the hardest.*

Save On Winter Power Bills.

Use your solar electric panel power in the winter time. Ask us about our line of accessories, including:

- Ceiling fans
- Lighting packages
- 12 volt battery charging
- Emergency power equipment

1751 East Henderson
Scottsdale, AZ 85251
(602) 223-5581 TELE

Special New Breeze™ Features.

Different sizes for different needs. Models are available for every room size and cooling capacity — ask your dealer.

Pump won't wear out. This unique "Spray-maker" pump is what makes the New Breeze™ so efficient. Unlike other cooler pumps, the "Spray-maker" is trouble-free. It can't wear out — it can't burn out.

Filter lasts longer. The patented New Breeze™ filter gives you better cooling. Unlike regular cellulose cooler filters, it will not promote bacterial growth or foul odors. And it's denser and thicker — so it lasts longer. That means cleaner air and fewer filter changes.

Optional nighttime cooling. A special optional package allows you to plug your New Breeze™ into standard household power or a 12 volt battery for nighttime cooling.

When morning sun strikes your solar electric panel, the New Breeze™ begins cooling. The New Breeze™ cleans and cools your air until nightfall.

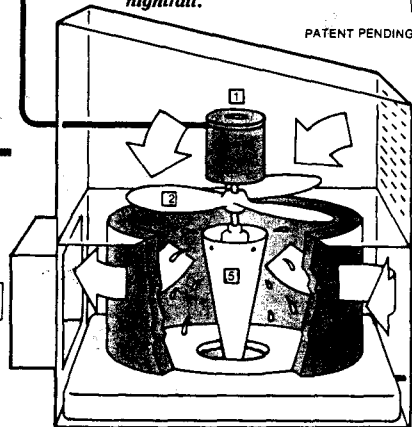

1. Motor 3. Warm air in 5. Pump
2. Fan 4. Water in 6. Cool air out

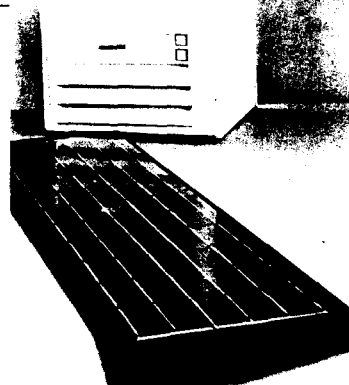

It's Easy To Install.

The New Breeze™ runs on safe 12 volt power, and is made to be installed by the owner. It's designed to fit comfortably in your home, with an attractive front plate that hugs your wall.

Setting up your New Breeze™ takes only a few hours. Using simple hand tools, install it in a window or through a wall. It's easy to connect the cooler to a water supply. Just hook it to a garden hose or faucet. Use the optional hand-pumped pressure tank where there is not running water.**

**The optional 3 gallon hand-pressurized water tank is available separately.

Dimensions of New Breeze™
Metal container: Width 17" Height 18½"
Depth 14¼" Front vent: Width 17"
Height 17" Depth 1½"

Recommendations For Using New Breeze™.

Evaporative coolers work best in dry, hot air. The more moisture that can be added to the air, the greater the possible temperature drop. New Breeze™ makes hot, dry air into a refreshing indoor climate. It is not recommended for areas where the average relative humidity exceeds 75%.

WARRANTIES.

New Breeze™ Cooling Unit: One year limited warranty.
"Spray-Maker" Pump: Three year limited warranty.
Arco Solar Electric Panels: Ten year limited warranty.

PRESENTED BY:



SOLAR POWER MECHANICAL COOLING SYSTEM

DEPENDABILITY

MasterCool is technology built to last! All the dependability of solar power, solid state electronics, and new chemical bonding processes has been incorporated in the solar powered MasterCool.

Power Master Reduces Utility Bills. The solid state Power Master controls your MasterCool with electronic semi-conductor integrated circuits first developed for NASA space craft, which demand the highest in energy efficiency and reliability.

The Power Master automatically powers the MasterCool from electricity generated by the solar modules during the day in the amount proportional to the intensity of the sun, reducing costly consumption of billable AC utility power... When the sun is at its hottest, your utility bill stays at a minimum day after day.

Photovoltaic solar energy has proven its dependability over the years. On NASA satellites, where reliability is a must, PV power has been used since 1953. For terrestrial applications, our PV modules have a design life of 20-30 years and carry a five year manufacturer's warranty.

The ARVIN exclusive polybond coating (polyester/epoxy) provides an appliance-like finish that protects the whole system from corrosion so well that we guarantee it for five years. In accelerated aging tests polybond kept out-performing the competition time after time.

ARVIN is the largest manufacturer of comfort coolers in the world. But should you need our help, dealer/contractor service centers are available in most western states.

So come on, enter a new era in cooling comfort with us and start saving a bundle on your utility bills today!

	Approximate KW/Hr. consumed during sunlight hours	The Solar Powered MasterCool saves you . . .
Solar Powered Arvin MasterCool, running at high speed	.75KW	—
Typical 3 Ton Air Conditioning unit	4.5KW	84% over air conditioning
Standard Arvin MasterCool without solar power, running at high speed	1.15KW	40% over standard utility powered MasterCool

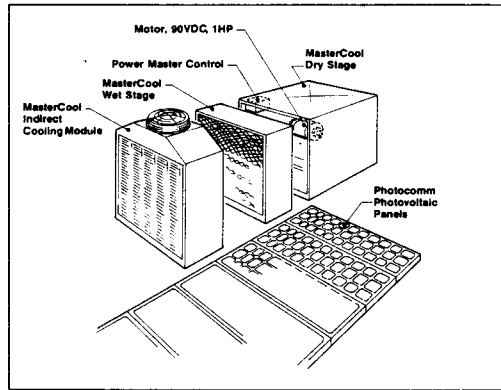

MasterCool is a registered trademark of Arvin Industries Inc.

Your authorized "Solar Powered MasterCool" Dealer

1. Kitchen tree

For architects facing the problem of how to design the tiny apartment kitchen, Global Furniture may offer the solution. The demountable *Kitchen Tree*, manufactured in West Germany by Tecta, incorporates a granite cooktop, sink, wood chopping board, shelving, utensil holders, and a dishcloth rack that are attached to a 76-in.-high stainless-steel utilities' column. All the accessories can be customized in a variety of finishes, and adjusted in height and direction to suit the user's needs. Global Furniture, New York City.

Write 300 on reader service card

2. Cooker

The legendary British Aga cooker—a favorite of professional cooks and such luminaries as Paul McCartney, John Updike, and Princess Diana—is now available in the U.S. Designed in the early 1920s by a Swedish Nobel Prize winner, Dr. Gustaf Dalen, it works on the principle of stored heat. Constant heat levels at different temperatures are simultaneously maintained in its roasting, baking, simmering, and warming ovens, which are vented to an outside flue. The custom-assembled cooker is fueled by gas or coal, and is offered in seven baked-enamel colors. Aga, Stowe, Vt.

Write 301 on reader service card

3. Italian kitchen

The *Gres* kitchen is designed by the Venetian architect, Roberto Pamio, and manufactured in Italy by Arclinea. The sleek components include rounded safety edges on all the cabinet doors, the drawers, and the white ceramic tiles that cover the countertops and shelves. A lighting fixture runs the length of the hanging cabinets to provide direct illumination over the work surfaces. Accessories such as a retracting iron, sliding knife holder, paper towel holder, and spice drawer can be installed on a track system underneath the cabinets. IPT, Long Island City, N. Y.

Write 302 on reader service card

4. Mixer

The *KV1* single-control kitchen/bar mixer (shown with sink Model 124) is part of the manufacturer's brass *Sanitary Fittings* series. Designed by the Danish architect, Arne Jacobsen, and selected by the Museum of Modern Art for its design collection, the mixer features a double swivel spout that allows the direction of the water flow to be easily adjusted. It is compatible with American plumbing standards and is available in 10 epoxy finishes, polished brass, and chrome. Kroin, Inc., Cambridge, Mass.

5. Tile

Dish Is It specializes in hand-painted, customized ceramic tiles such as *Sahara*, the speckled pattern installed in last year's San Francisco Decorator's Showcase kitchen designed by Dan Phipps (shown). Tile patterns can be specified in any combination of 70 standard colors, and in matte and gloss finishes. Matte floor tiles are also available, and the firm provides consultation for custom designs. Dish Is It, San Francisco.

Write 304 on reader service card

6. Italian tiles

This selection of 18 patterns from 9 manufacturers illustrates the diversity of Italian-made ceramic tiles now offered in the U.S. Included are geometric patterned, mottled, terrazzo-like, and textured tiles from Campeginese, L'Astoria, Gubbio, Artcolor, Gabbianelli, Toscana, Metroquadro, La Faenza, and Sant'Agostino. Italian Tile Center, New York City.

Write 305 on reader service card

7. Laminates

The manufacturer has introduced six new patterned and woodgrained, high-pressure laminates that are designed to coordinate with the manufacturer's *Color Grid* and *Color Trends* collection of solid colors. Included in this new line are *American Granite*, intended to simulate real stone, and *Papercraft*, meant to resemble fine, handmade paper with visible fibers. *Dust* (shown) features a grainy, sandlike surface in both matte and polished finishes. Formica Corp., Wayne, N. J. D. K. D.

Write 306 on reader service card

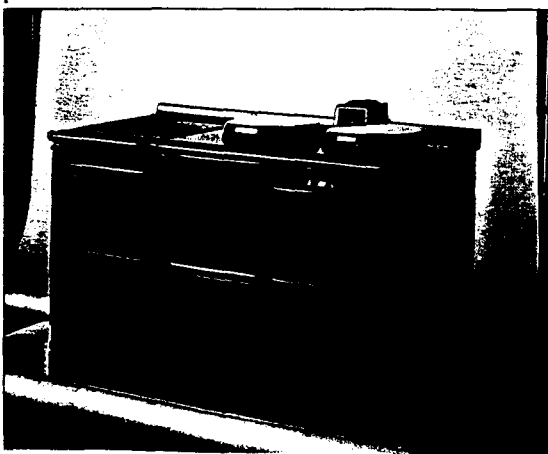
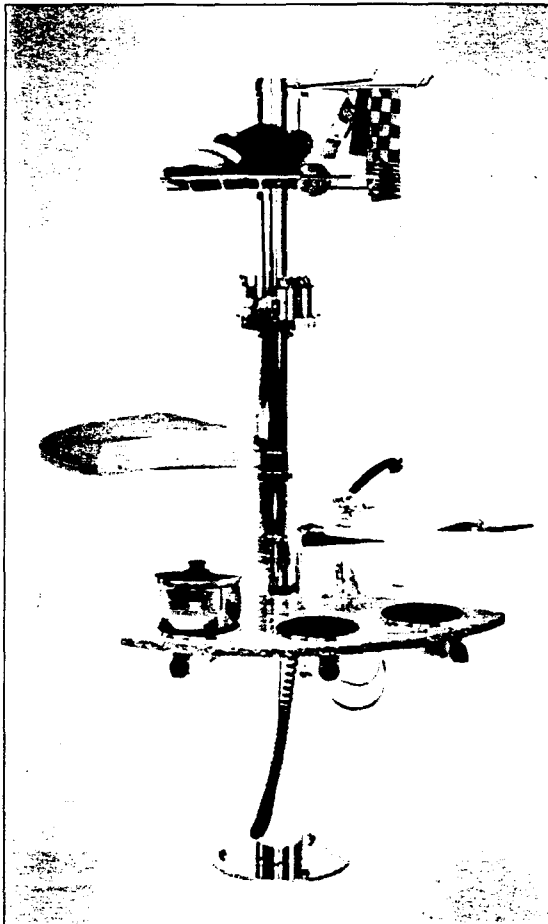

SOLAR HOT WATER

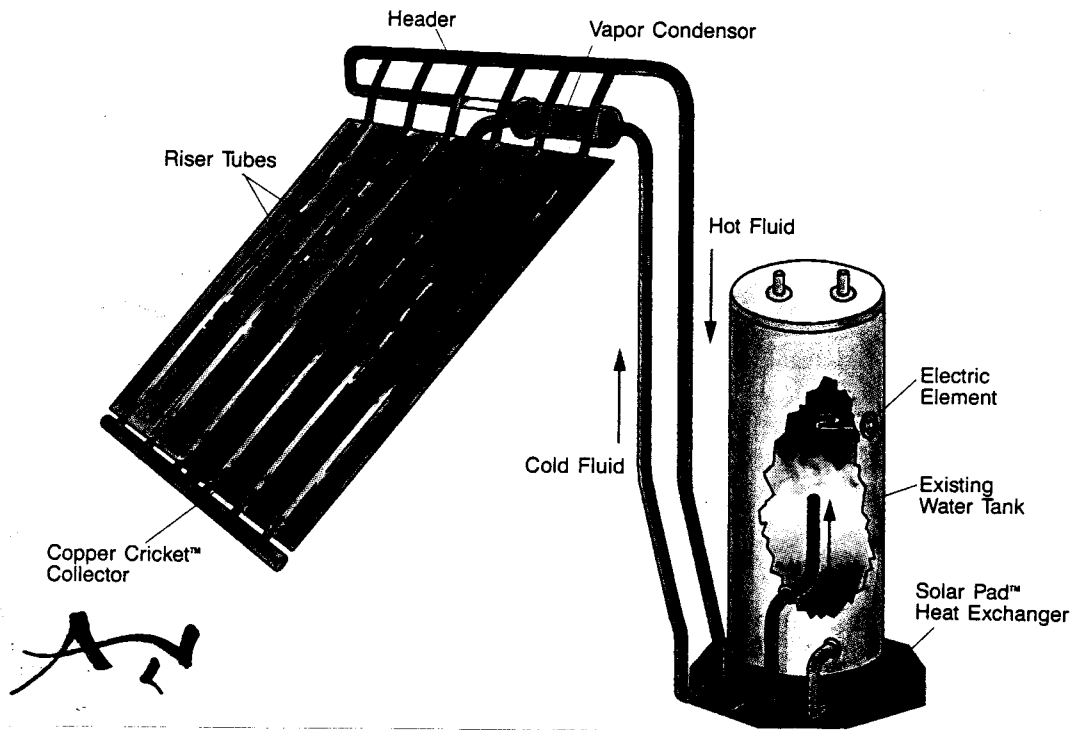

SOLAR DISTILLATION

How it works:

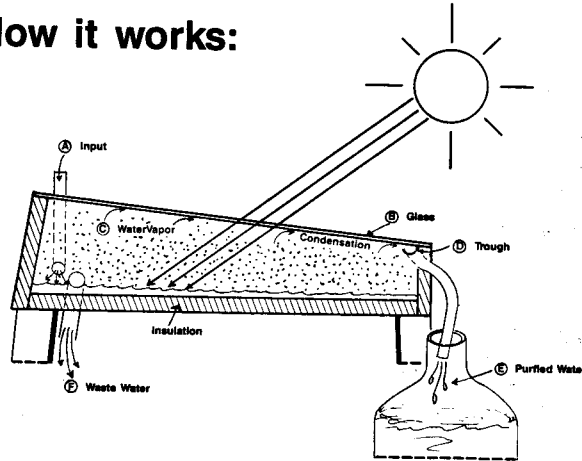

- A) Feed water goes into the input pipe and inside the still.
- B) The sun's rays penetrate the glass surface causing the water to become hot.
- C) The water evaporates (see water vapor) and condenses on the underside of the glass.
- D) This water runs down the glass into a trough and out a pipe...
- E) And into the container as purified water.
- F) Extra water fed into the still flushes out concentrated waste.

Why SUNWATER™ Solar Stills?

- Sunwater purity is very high.
- Cost of purified water is comparatively low.
- Convenience is maximized.
- Maintenance is minimized.
- Overall - A SUPERIOR SYSTEM.
(backed by nearly 30 years' experience!)

NEW FROM



COPPERCORE™

THE HIGH PERFORMANCE, COMPACT, WATER HEATER WITH THE SOLID COPPER STORAGE VESSEL THAT'S GUARANTEED FOR 20 YEARS!

INSTANT HOT WATER

SUPER-SPEED "RECOVERY"

Compact Design, Long Life, Simple Installation — these are the features that make Thermar's CopperCore the ideal choice for "point of use" hot water needs in residential, commercial, and industrial locations. Injection-moulded full-foam insulation surrounded by a steel jacket encases the entire unit for efficient energy conservation. **HIGHEST QUALITY** — a Thermar hallmark — is evidenced throughout every design and manufacturing detail.

- CopperCore — operates on ordinary house current (110-120 Volts — 1500 Watts).
- Solid Copper, construction — nothing to leak.
- Elements easily replaceable — use a standard screw in element.
- Temperature range 110-170°F.
- Storage vessel fully encapsulated in polyurethane foam then jacketed in steel for high operating efficiency.
- Tiny in size—only 12" by 9" by 9" deep!
- Can be mounted almost anywhere — under sink, inside cabinets, etc.
- Handsome, compact design — compliments modern kitchen, office, or bath decor.
- Just plug it in, and get hot water.
- Ideal for any application where remote hot water is needed. In kitchen, for use at hairdressing "wash stations", offices, stores. Compactness combined with simple installation makes this one of the most practical heater designs ever.



MYSON

SANTON Electric
Mini-Storage
Water Heater



The Ideal Point-of-Use
Electric Water Heater



- Two-gallon, all-copper mini-storage tank
- Small enough to fit under sinks, inside cabinets or almost anywhere else
- Just 14 lbs.; easy to install and service
- Ideal for home use or for commercial installation in office buildings, public lavatories, or other places of business

OWNER OR LABOR BUILT PLUMBING SYSTEM

QEST®

Polybutylene Plumbing System

Do-It-Yourself Plumbing Guide

- Pipe Sizing Guide
- Projects
- Part Selection

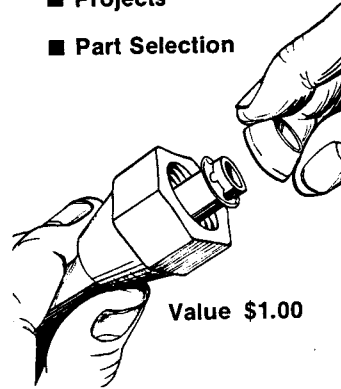

Pipe Sizing Guide

GLOSSARY
OD Outside Diameter
CTS Copper Tube Size
IPS Iron Pipe Size

OD SIZES

- 1/4" (1/8" CTS)
- 3/8" (1/4" CTS)
- 1/2" (3/8" CTS)
- 5/8" (1/2" CTS)
- 7/8" (3/4" CTS)

IPS SIZES

- 3/8"
- 1/2"
- 3/4"

QEST® SURE AND EASY PLUMBING

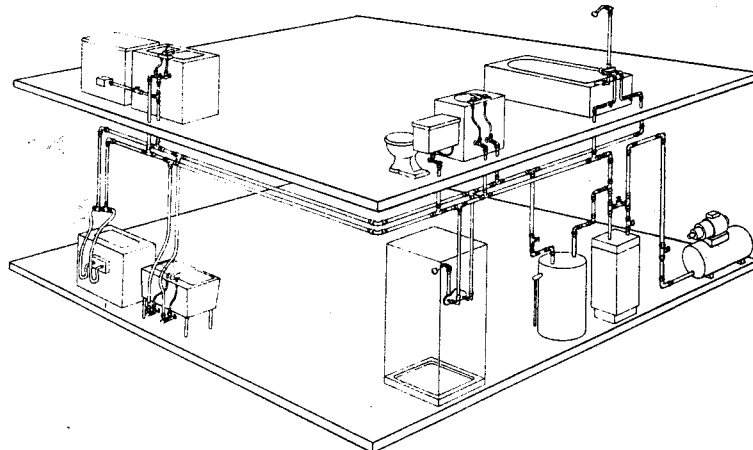
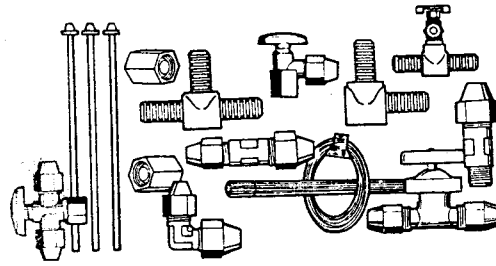

LOW WATER FAUCETS

Touch & Flow FAUCET For Public Facilities



DEA Touch & Flow Faucet Model 25-042

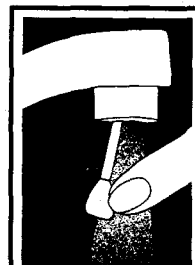

A TOUCH of the clapper in any direction opens the water valve—RELEASE, and the water-flow stops.

SAVES You Water And Dollars!

- **Save Water-** Touch & Flow action is a water conservation breakthrough. The water only runs when hands are under the faucet!
- **Save Dollars-** Less water flow lowers water bills. Plus, cleaner restrooms mean lower maintenance.
- **Sanitary-** No handles to touch mean more sanitary facilities, especially important in restaurants!
- **Adjustable Flow-** Easily adjusted by maintenance personnel from 1/2 GPM to 2 3/4 GPM

ALomat hand-free faucet

The first radar electronic actuated lavatory faucet. Vandal-resistant, solid cast brass body.

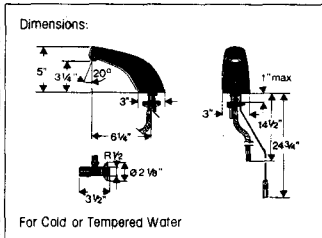
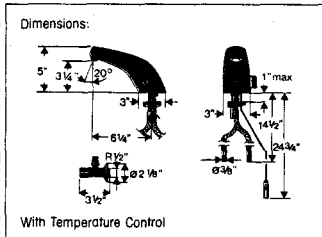
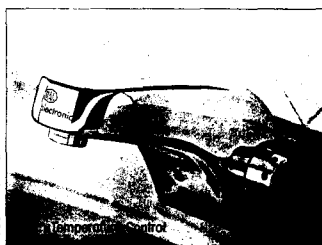

NOTE: The 1/2" x 3/8" Supply Stop Valve with integrated strainer and flexible stainless steel supply connection furnished by DAL must be installed to maintain Product Warranty.

WITH TEMPERATURE CONTROL:

DALomat Series 886.02, radar electronic actuated Lavatory Faucet with manual temperature control, concealed temperature limit setting, integrated radar electronic in vandal-resistant cast brass spout, 1/2" solenoid valve, two check valves, aerator with 1.5 gpm flow control, hv flexible stainless steel supply connections, supply stop valves with integrated strainers. To be installed with DAL 12/24V, UL Listed Power Unit.

- 886.02.511 Polished Chrome
- 886.70.511 Satin Chrome
- 886.30.511 Polished Brass
- 886.50.511 Gold Plated
- 886.XX.511 Epoxy Color Finishes available upon request

Options

- With Moderator to meet Hospital Specs.

FOR COLD OR TEMPERED WATER:

DALomat Series 887.02, radar electronic actuated Lavatory Faucet for cold or tempered water, integrated radar electronic in vandal-resistant cast brass spout, 1/2" solenoid valve, aerator with 1.5 gpm flow control, flexible stainless steel supply connection, supply stop valve with integrated strainer. To be installed with DAL 12/24V, UL Listed Power Unit.

- 887.02.511 Polished Chrome
- 887.70.511 Satin Chrome
- 887.30.511 Polished Brass
- 887.50.511 Gold Plated
- 887.XX.511 Epoxy Color Finishes available upon request

Options

- With Moderator to meet Hospital Specs.

ALomat offers utmost hygiene, maximum comfort, and high savings of water and energy. ALomat is highly recommended for medical, laboratory, food handling and other places where sanitary conditions are essential.

AL American, Inc.

HANDS-FREE FAUCET

With Thermatronic, you can regulate water-flow temperature and duration without touching anything. The wall-mounted microprocessor control panel has five light-emitting diodes, labeled HOT, WARM, COLD, and SHORT, LONG. Wave a hand above the unit, and it activates. Hold your hand over the infrared sensor, and the indicator lights cycle through the HOT,

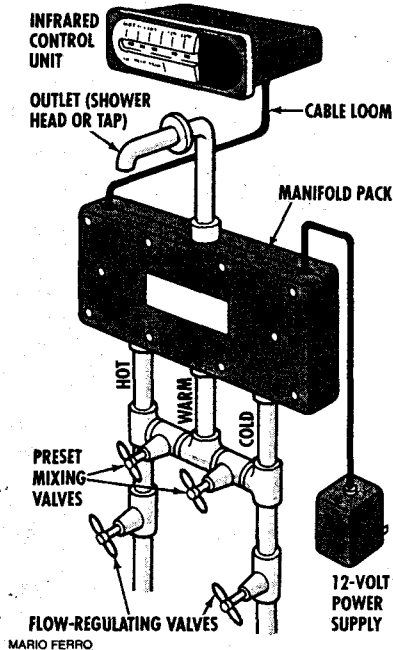
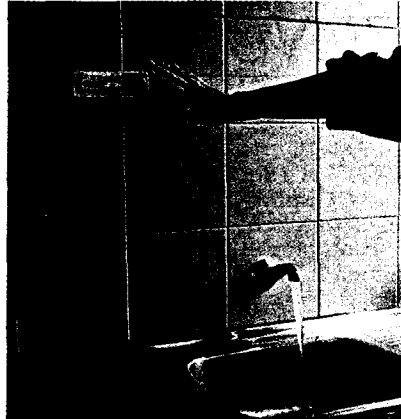

WARM, or COLD and SHORT, then the HOT, WARM, or COLD and LONG settings. Remove your hand to choose, and the water starts. The warm temperature is preset to 93 degrees F by mixer valves between the hot and cold supply inlets. These three pipes feed into a manifold pack containing near-silent soft-closure solenoid valves operated by a control unit, which regulate outlet temperature. Flow duration is preset, with the SHORT variable lasting from 8 to 12 seconds, and LONG, 8 to 12 minutes. The automatic cut-off conserves water and thermal energy, but the flow can be stopped with a hand wave, and likewise restored. Thermatronic also prevents electric-shock hazards with a 12-volt DC power supply. Ryemetal Forgings (Vic.) Pty. Ltd., Box 344, Dandenong, Victoria 3175, Australia.—David Scott

TOTAL WATER RECYCLING TOILETS

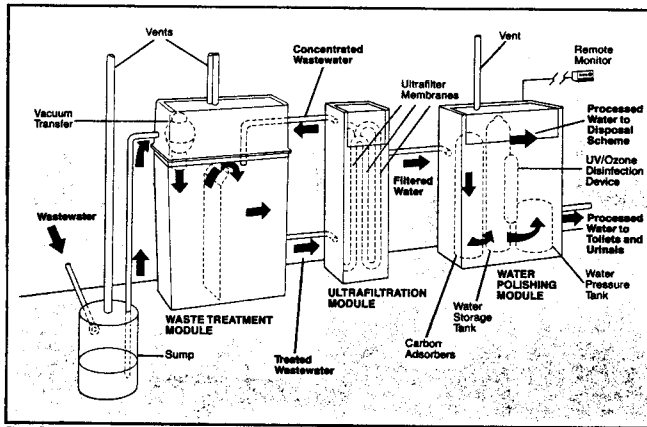
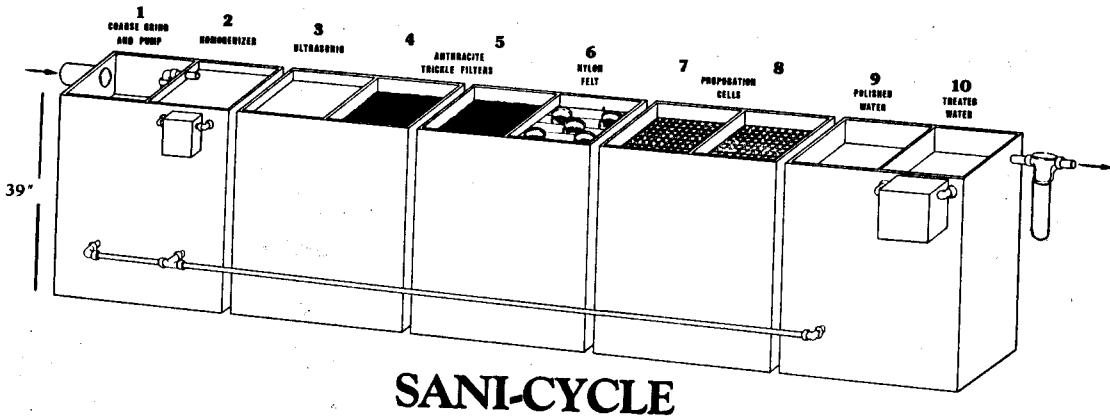
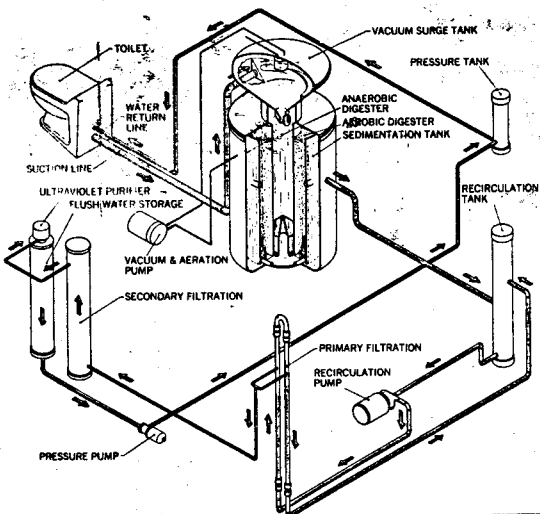
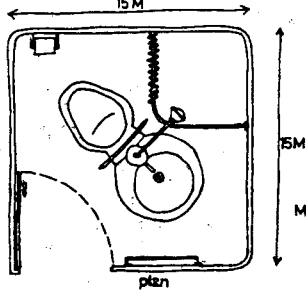
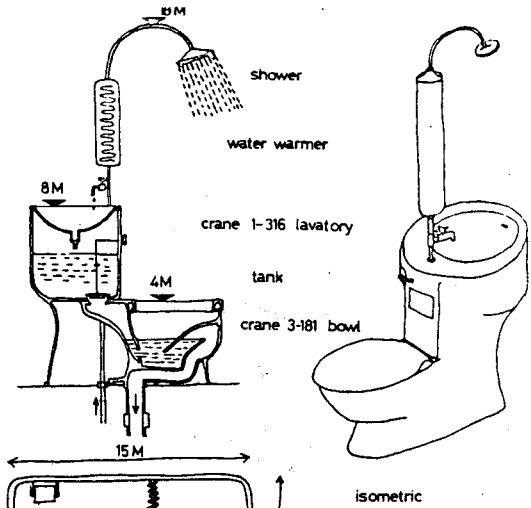

Figure 7. The Cycle of Flow Diagram

THETFORD CORPORATION
 Waste Treatment Products Division
 P.O. Box 1285
 Ann Arbor, Michigan 48106
 Telephone (313) 769-6000



SINK WATER TO COMMODE



MINIMUM SANITARY UNIT 1

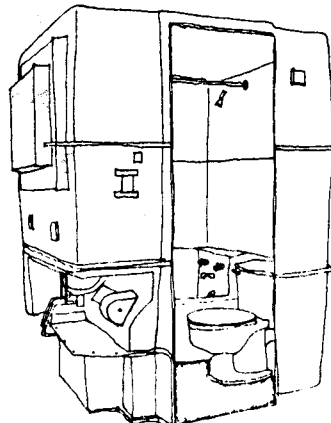
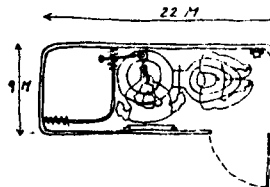
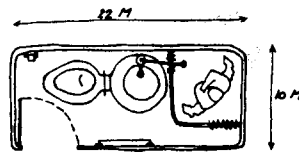
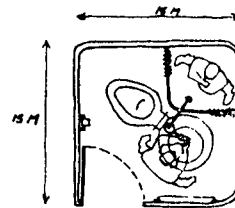
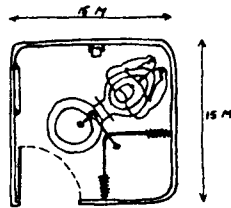

Above, alternative locations of the unit in different sized shells.

Left, a four piece modular bathroom unit of 650 pounds (295 kg.) shipping weight. Each section can be installed by two men without cutting or fitting, and takes a matter of hours. The walls, tub and lavatory are of reinforced plastic. Supply pipes and fittings come in integral assemblies, so the only work done on-site is roughing-in and electrical work.

The unit is manufactured by Crane Co., New York City, and costs US \$ 1,719, including ventilator and ventilator/heater. This cost is too high for the majority of people. Transportation costs from the factory in Alliance, Ohio must also be considered.

CASCADE

The Cascade is a U.S.-made version of the pioneering Ifo design from Sweden, millions of which are in operation throughout the world. It features an elegant oval tank that differentiates it from other toilets and for this reason is a favorite with designers. Operation is simple: lifting the knob raises the plunger and lets water drop into a diverter tube that shoots the water around the rim of the bowl. A built-in dam in the tank assures that only the water with the greatest head pressure is used for the flush, unlike other toilets that empty the tank. The flush is extremely rapid and thoroughly scours both the bowl and pipes. Both round-bowl and elongated-bowl versions are available.

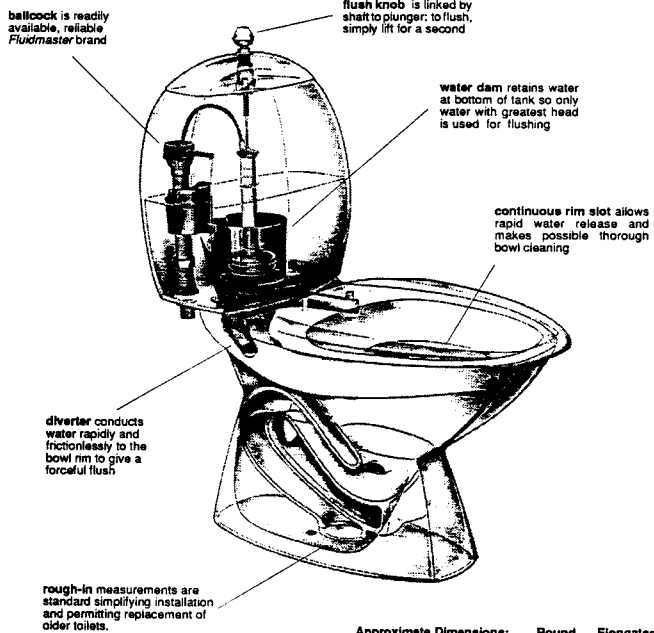

Approximate Dimensions: Round Elongated

back wall to drain center
bowl rim to floor
bowl tip to back wall
height to top of flush knob
widest point of toilet

12"
12"
15"
14"
27"
29"
33"
32"
15"
15"

TINY BATHROOMS

COMPARTMENT LENGTH DIMENSION "A"	SHOWER PAN LENGTH DIMENSION "B"	OPTIONAL SHOWER PAN ORDER NO.
36 INCHES	27 INCHES	8095-2
39 INCHES	30 INCHES	8095-3
42 INCHES	33 INCHES	8095-4

DIMENSION "A" APPLIES ONLY WHEN MONOGRAM SHOWER PAN IS USED

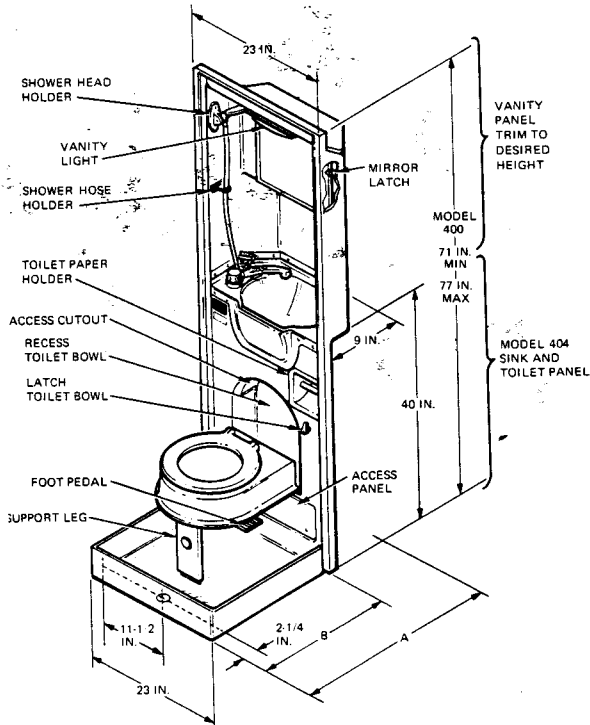

LOW WATER

COMMODES

TOTO

The Toto is made in Indonesia by Asia's largest and most advanced plumbing manufacturer. We highly recommend it for those who seek a conventional-looking toilet but who don't want to sacrifice quality. Although it is fairly inexpensive, it is far superior to most other ultra-low-flush toilets in its class. In fact, laboratory test results show the Toto performs as well or better than any other toilet available today, regardless of water use, cost, or design. It features a finish quality as good as any we've seen, and it uses a quality Fluidmaster ballcock. Unlike our other toilets, the internal parts are not installed, but assembly is simple and should only take a few minutes.

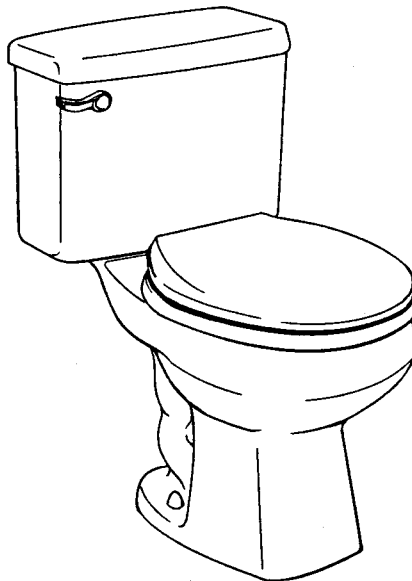

VENETO

The Veneto is a French-made one-piece toilet in which the tank is part of the bowl. It features elegant European styling, superb china quality, and ultra-quiet operation. Water in the tank is held by a durable plastic inner tank that isolates it from the china and eliminates tank condensation. It flushes by pushing a button in the center of the lid. The flush is rapid and thoroughly scours both the bowl and pipes. This toilet does not take a standard seat, so we provide a very high quality European seat at no additional cost. A stainless-steel water-fill hose is also included as standard.

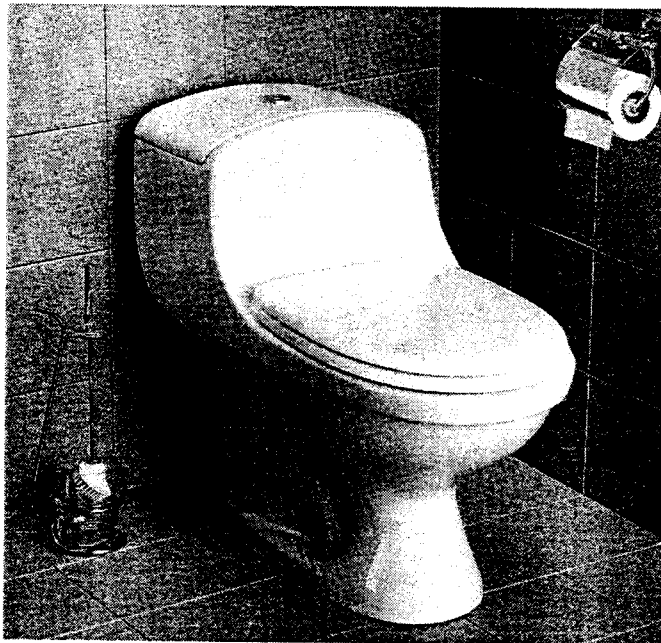

Approximate Dimensions:

back wall to drain center	12"
bowl rim to floor	15"
bowl tip to back wall	29"
height to top of lid	25"
widest point of toilet	15"

COMPOST COMMODES

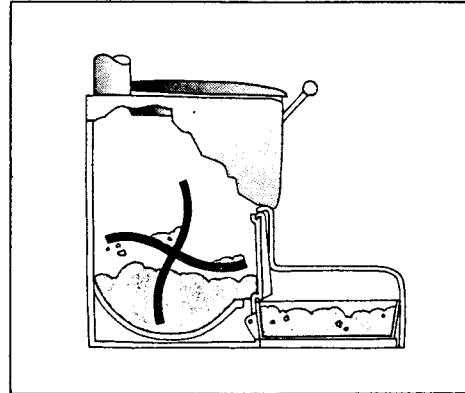

Tested

In Sweden, the Bio-loo is the most popular system of its kind, with several thousand units in operation. The Bio-loo was introduced in 1975, after extensive research and development, and scientific testing to prove its safety and reliability.

No other sanitary system has all these features:

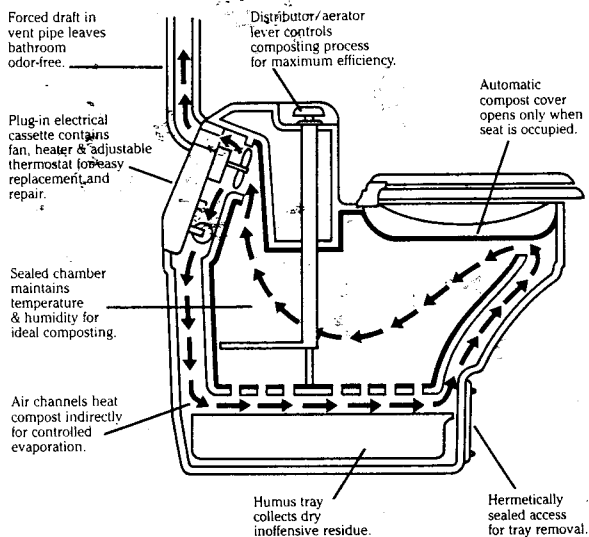

Parts List

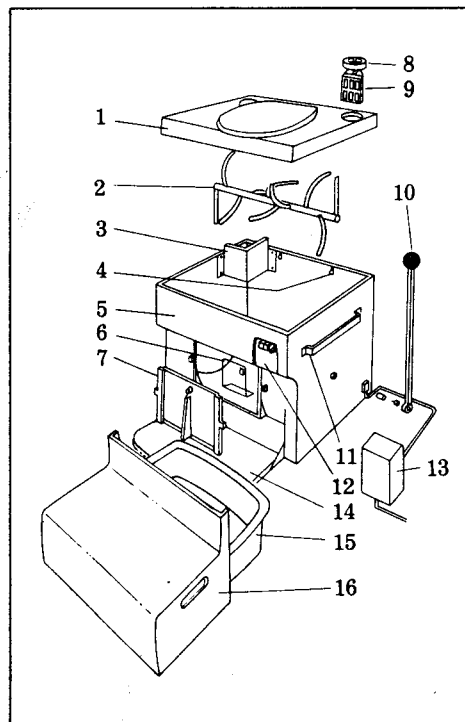

Arco Solar Photovoltaic Modules

Arco M-75

The Arco M-75 is far and away our best selling module. It produces 48 watts at 15.9 volts. The M-75 is efficient, attractive, easy to install, and comes with a wired-in bypass diode in each junction cover. The M-75 consists of 33 cells in series. Each module comes with an easy to understand instruction manual. With its high amperage (3 amps at load) it has become the staple in stand-alone systems today.

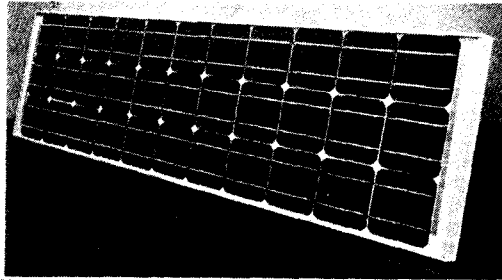

Power Specifications*	
Model	M75
Rated Power	48 Watts
Current (typical at load)	3.02 Amps
Voltage (typical at load)	15.9 Volts
Short Circuit Current (typical)	3.4 Amps
Open Circuit Voltage (typical)	19.8 Volts
Physical Characteristics	
Length	48 in./1219 mm
Width	13 in./330 mm
Depth	1.4 in./36 mm
Weight	11.6 lb/5.2 kg

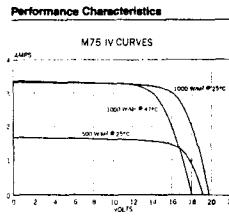

The I-V curve (current vs. voltage) above demonstrates typical power response to various light levels at 25°C and a 47°C cell temperature.

Arco M-75 (48 watt) (Qty 1-3) **\$389**
 (Qty 4-11) **\$369**
 (Qty 12+) **\$359**
 Ship wt. 21#

Arco M-78

The Arco M-78 is the underrated version of the M-75. It is exactly the same size as the M-75, but when Arco tests their modules, those that come out less than 48 watts get classified as M-78's, guaranteed to produce at least 40 watts at 16.0 volts, usually more.

Arco M-78 (38+ watts) (Qty 1-3) **\$339**
 (Qty 4-11) **\$319**
 (Qty 12+) **\$309**
 Ship wt. 21#

Arco M-65

The M-65 is designed primarily for RV, marine, and remote home usage; only one module is employed. The M-65 consists of 30 cells wired in series. It is a "self-regulating" module that decreases its current output from 3 amps to less than 1/2 amp when the battery approaches full charge, eliminating the need for a charge controller, but often seriously limiting the module's output. Not recommended for very hot climates where temperatures often exceed 100° F. The Arco M-65 produces 43 watts at 14.5 volts for a current of 2.97 amps.

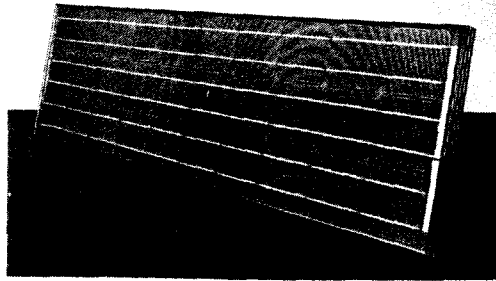

Power Specifications*	
Model	M65
Rated Power	43 Watts
Current (typical at load)	2.95 Amps
Voltage (typical at load)	14.6 Volts
Short Circuit Current (typical)	3.3 Amps
Open Circuit Voltage (typical)	18.0 Volts
Physical Characteristics	
Length	42.6 in./1083 mm
Width	13 in./330 mm
Depth	1.4 in./36 mm
Weight	10.5 lb/4.8 kg

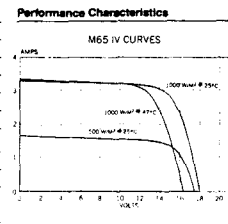

The I-V curve (current vs. voltage) above demonstrates typical power response to various light levels at 25°C and a 47°C cell temperature.

Arco M-65 (Qty 1-3) **\$359**
 (Qty 4-11) **\$339**
 (Qty 12+) **\$329**
 Ship wt. 16#

Power Specifications*	
Model	M78
Rated Power	40 Watts
Current (typical at load)	2.55 Amps
Voltage (typical at load)	15.7 Volts
Short Circuit Current (typical)	3.0 Amps
Open Circuit Voltage (typical)	19.5 Volts
Physical Characteristics	
Length	48 in./1219 mm
Width	13 in./330 mm
Depth	1.4 in./36 mm
Weight	11.6 lb/5.2 kg

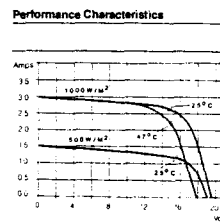

The I-V curve (current vs. voltage) above demonstrates typical power response to various light levels at 25°C and a 47°C cell temperature.

ENERGY CONSERVING LIGHTING

Surface Mount Lights

The ST 130 series are economically priced, practical lights that feature prepainted aluminum housings and acrylic diffuser lenses. They are available as large as 5 feet long with two standard 40-watt AC fluorescent tubes to meet maximum lighting requirements. Where practicality is the principal consideration, the ST 130 series suit the requirement perfectly.

130

16 watt 12VDC light. 12"x5-3/8"x1-3/4". 1.5 amps. Uses two F8T5/CW fluorescent tubes. 800 design lumens.

130 **\$31.55**
Ship wt. 3#

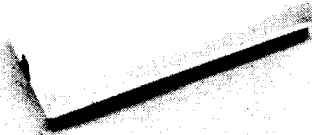

134

30 watt 12VDC light. 18"x5-3/8"x1-3/4". 2.1 amps. Uses two F15T8/CW fluorescent tubes. 1,760 design lumens.

134 **\$34.50**
Ship wt. 4#

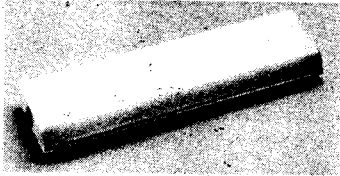

137

20 watt 12VDC light. 24"x5-3/8"x1-3/4". 1.6 amps. Uses one F20T12/CW fluorescent tube. 1,250 design lumens.

137 **\$42.85**
Ship wt. 3#

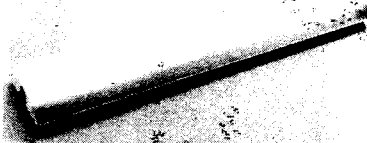

32 watt 12VDC circline, 13-1/4" diameter x 2-1/4" deep. 1.9 amps. Uses one FC12T9/CW fluorescent tube. Light output: 1,900 lumens.

110 **\$52.05**
Ship wt. 6#

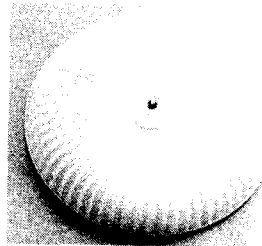

111

8 watt 12VDC light. 12"x4"x1" thin. 0.7 amps. Uses one F8T5/CW fluorescent tube. Light output: 400 lumens.

111 **\$31.50**
Ship wt. \$31.50



112

16 watt 12VDC light. 2"x5-1/2"x1" thin. 1.6 amps. Uses two F8T5/CW fluorescent tubes. Light output: 800 lumens.

112 **\$38.40**
Ship wt. 3#

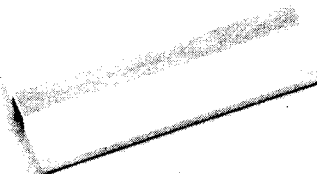

115

15 watt 12VDC light. 18"x4"x1-3/8" deep. 1.4 amps. Uses one F15T8/CW fluorescent tube. Light output: 800 lumens.

115 **\$30.90**
Ship wt. 4#

